

# CooperTools

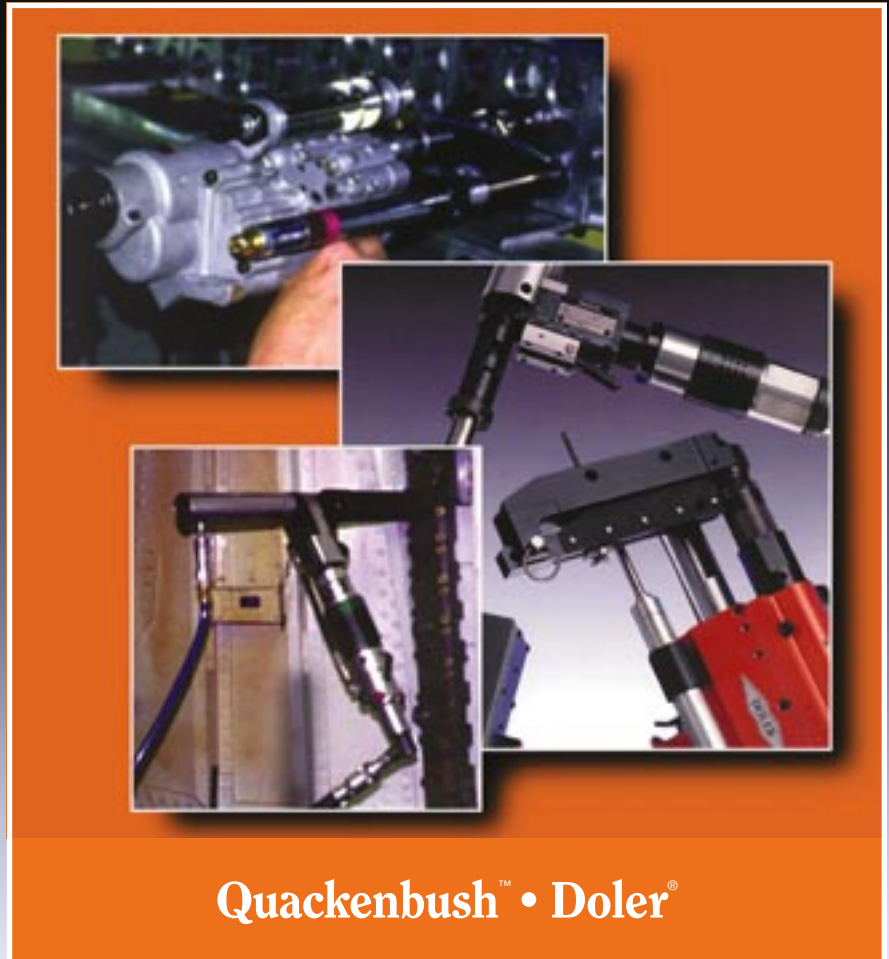

**ADVANCED DRILLING EQUIPMENT**

**COOPER** Tools

# ISO 9001

## Quality System Certified

CooperTools Division has attained ISO 9001 Quality System Certification for eight of our facilities. The driving force behind the implementation of the Quality System is the commitment “to provide our customers with the **best value delivered** by offering only products and services **that meet or exceed their expectations**”.



Lexington, South Carolina



Dayton, Ohio



Hicksville, Ohio



Springfield, Ohio



Westhausen, Germany



Ozoir-la-Ferrière, France



Houston, Texas

# CooperTools Advanced Drilling Equipment

Introduction

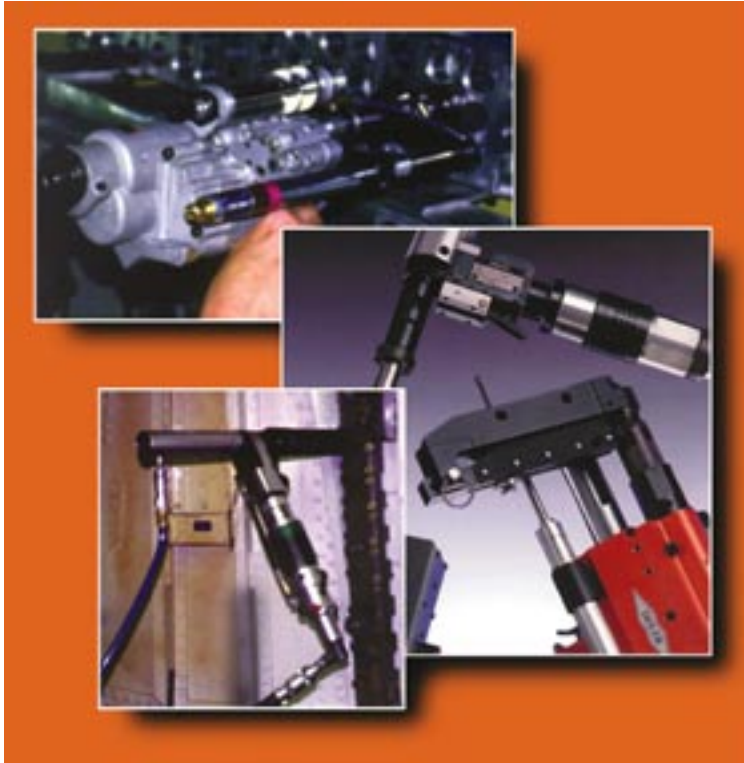

## ***Our Tools Are So Much In Demand Because We Demand So Much From Our Tools***

Advanced Drilling Equipment from CooperTools is the most complete and the most comprehensive line of drilling systems available to the aerospace industry.

Branded under the highly respected Doler and Quackenbush names, the Cooper line represents "the best of the best," encompassing the premium features from a number of tool lines our company has acquired over the years.

All of the tools in the Advanced Drilling Equipment line are designed to be fixture-mounted, with torque and thrust counteracted by the fixture, not by the operator.

These tools do not rely on the variable strength of manpower to push against a drill, which means they deliver greater accuracy, repeatability and consistency of hole integrity, as well as greatly reduced fatigue and chance of injury to the operator.

We have designed our tools to help you achieve optimum hole quality, including diameter, angularity and depth tolerances. Of course, the drill is but one factor that effects hole quality. The condition of the cutter, fixture, bushing in the fixture, lubrication, and the skill of the operator are major factors.

And to ensure that our tools and accessories are the best in their class, we go to extraordinary lengths in design, testing, manufacturing and quality control to meet or exceed the highest international standards.

**Quackenbush  
158 QGB  
Inline Positive  
Feed Drill**



**Quackenbush 140 QGDA Right Angle Positive Feed Drill**



After all, the aerospace industry offers perhaps the most critical and exacting proving ground in contemporary business. Professionally, we are deeply committed to maintaining our leadership position in this most dynamic and sophisticated manufacturing environment.

And, selfishly, we demand so much from our tools today, because we will probably be riding on one of your planes tomorrow.

# CooperTools Advanced Drilling Equipment

---

## Introduction

### ***Assuring You Of The Right Tool For The Right Application***

---

The Advanced Drilling Equipment line has been developed to address the singular nature of achieving optimum hole quality in the aerospace industry.

In most traditional industries, precision holes can be successfully drilled with a drill press or CNC machine. But because a significant number of aircraft components are too large, too complex and too irregularly shaped to be taken to a machining center, portable precision drill motors must be taken to the plane itself. It is impractical to drill precision holes in a wing, fuselage or engine nacelle any other way.

The wide range of hole sizes, the critically close tolerances required of those holes and the divergent materials used in the aerospace manufacturing industry demand that these portable precision drill

motors be available with a remarkably broad range of cutter speeds, feed rate combinations, and physical properties that can accommodate virtually any work-space or application.

Responding successfully to these demands for quality and flexibility has made the CooperTools Advanced Drilling Equipment line the most impressive, and the most respected, in the business.

Included are positive feed drills for deep hole drilling in in-line, piggyback, and right angle configurations, peck drills designed specifically to enhance hole quality when drilling through layers of dissimilar materials, and self colleting drills that are perfect for drilling smaller holes throughout the aircraft.

We invite your attention to a detailed picture of the various Advanced Drilling Equipment tools and accessories in the pages that follow.

***Doler P3 Self Colleting Drill***

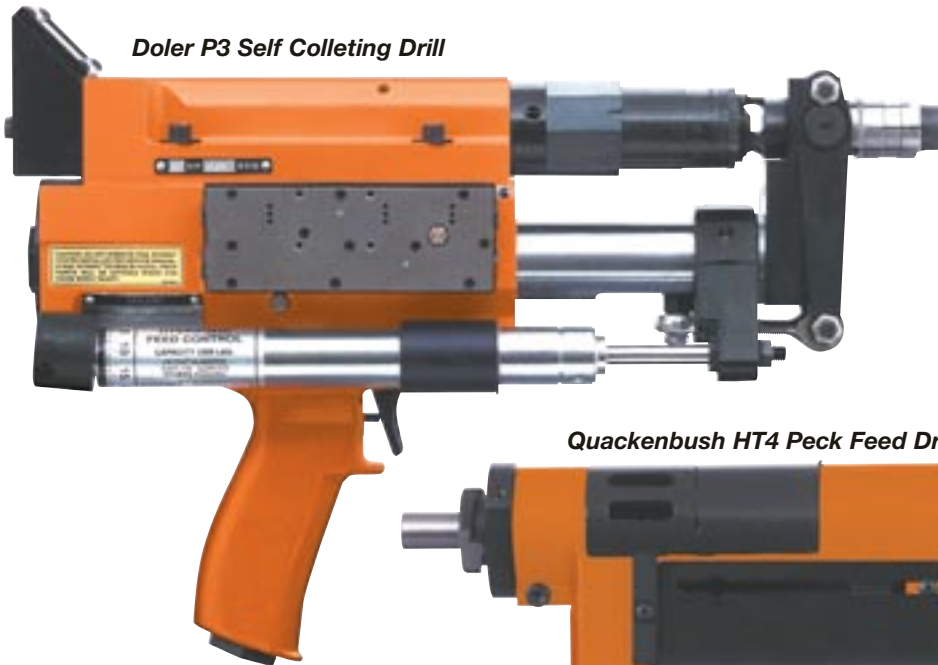

***Quackenbush HT4 Peck Feed Drill***



## Selecting The Right Tool

The old saying, “you’ve got to have the right tool to do the job right”, is so true in regards to advanced drilling equipment. For certain applications, as shown in the diagram below, a specific tool is required. However, other applications may be served by more than one tool. Detailed analysis by one of our experienced technical assistants will help you make the right tool selection for your particular applications. Some factors to consider are fixturing costs, access, hole quality, material(s) being drilled, production rate, budget, and familiarity with product.

-  **Peck Feed Drill**
  - Stacks of different materials
  - Close tolerance, one-shot drilling
-  **Peck Feed or Positive Feed Drill**
-  **Positive Feed Drill**
  - Work hardening materials
  - Controlled fixed feed rates
  - Drilling stroke >4 inches
-  **Positive Feed or Self Clamping Drill**
-  **Self Clamping Drill**
  - Drilling and countersinking of wings and fuselage
  - Nutplate holes
-  **Self Clamping or Peck Feed Drill**
-  **Peck Feed or Positive Feed or Self Clamping Drill**

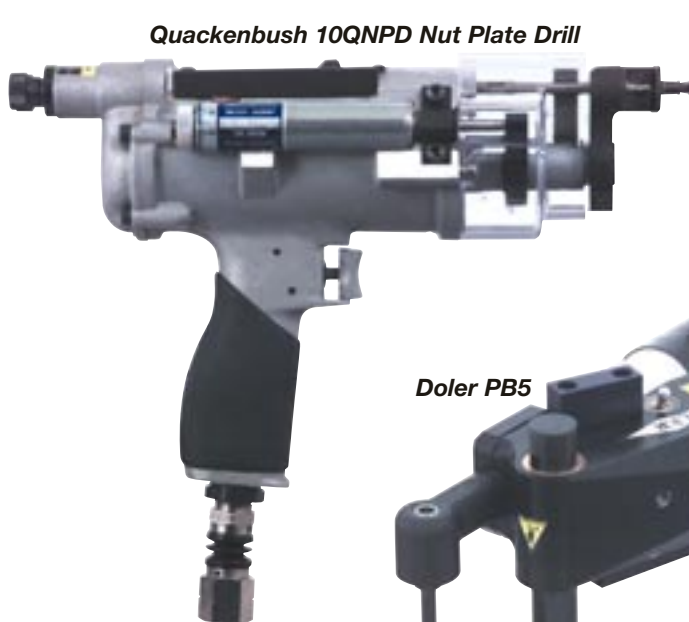
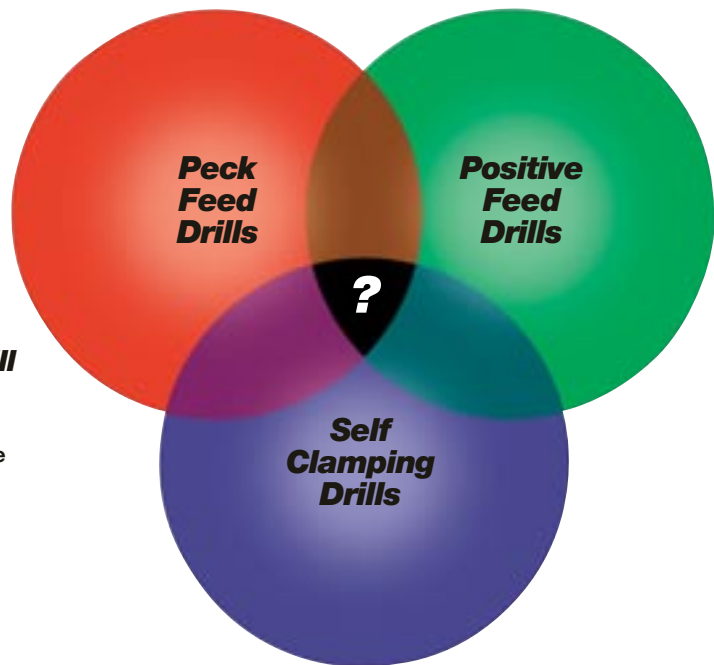

# CooperTools Advanced Drilling Equipment

## Introduction

### Speed, Feed & Power

Please use the chart below as a guide only. Many variables contribute to the optimum parameters for each application. These variables include: particular material characteristics, cutter design, cutter sharpness, airline pressure and flow capacity and cutter lubrication.

All portable drilling tools have limited power and thrust. In most cases, holes over 1/2 inch diameter cannot be produced at machine tool rates. Feed rates and/or speeds are reduced. Consult CooperTools for advise on particular applications.

### For best results with your drilling system:

1. Maintain lubricated air to the tool with pressure of 90 psig *while the tool is running.*
2. Use high quality cutters.
3. Replace cutters when point dulls – hole diameter generally increases, cycle times lengthen (*except positive feed*) and hole finish worsens.
4. Whenever possible, provide lubricant mist to the drill point.
5. Insure there is an adequate flow path for drill chips (*swarf*).
6. Utilize fixtures that are secure and rigid.
7. Assure that accessory items are sized correctly and working properly.
8. Train operating personnel in the proper use of the tool.

Material	Function	Drill Diameter						
		1/8	3/16	1/4	5/16	3/8	7/16	1/2
		.125	.188	.250	.313	.375	.437	.500
Aluminum (300 SFM)	Speed (RPM)	9000	6000	4600	3600	3000	2600	2300
	Feed Rate (IPR)	.002	.003	.004	.004	.004	.004	.004
	Power (HP)	.2	.3	.6	1.0	1.5	1.8	2.0
Mild Steel (90 SFM)	Speed (RPM)	2700	1800	1300	1100	900	750	650
	Feed Rate (IPR)	.005	.005	.005	.006	.006	.006	.006
	Power (HP)	.2	.3	.6	1.0	1.5	1.8	2.0
High Strength Steel Stainless Steel (30 SFM)	Speed (RPM)	900	600	450	375	300	250	220
	Feed Rate (IPR)	.001	.001	.001	.001	.001	.001	.001
	Power (HP)	.2	.3	.6	1.0	1.5	1.8	2.0
Titanium/Inconel (20 SFM)	Speed (RPM)	600	400	300	250	200	175	150
	Feed Rate (IPR)	.002	.003	.003	.003	.004	.004	.005
	Power (HP)	.2	.3	.6	1.0	1.5	1.8	2.0

**Composites** Graphite, kevlar, fiberglass, and other composite materials vary widely. Fiber, resin, processing method and type of cutting tool all affect the optimum drilling speed and feedrate. Little power or thrust is normally required, but controlled feedrates at the proper speed is mandatory. Carbide or diamond cutting tools are required. Contact your material supplier or experiment with an NC Drilling Machine.

**Stacks of Various Materials** Use the lowest speed and feedrate of the materials in the stack. Peck feed drilling is best.

A. Peck Drilling permits higher drilling speeds    B. Carbide cutting tools (when applicable) permits higher drilling speeds    C. Oil hole cutting tools permit higher drilling speeds.

### Speed (RPM)

Describes the number of revolutions of the spindle per unit of time.

Example: *Revolutions per minute=RPM*

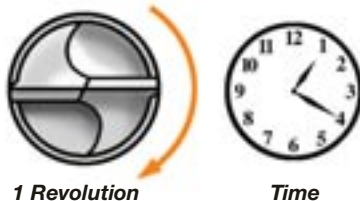

$$\text{Speed} = \text{Revolution} \div \text{Time}$$

### Surface Speed (SFM)

Describes the velocity (*speed*) of the **outside** of the drill bit.

Example: *30 surface feet per minute (30 SFM)*

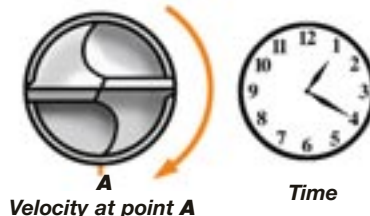

$$\text{Surface Speed} = \text{Distance} \div \text{Time} \text{ (rotational)}$$

### Feed Rate (IPR)

Describes the distance the spindle travels during each revolution.

Example: *0.002 inches per revolution = .002 IPR*



$$\text{Feed Rate} = \text{Distance} \div \text{Revolution}$$

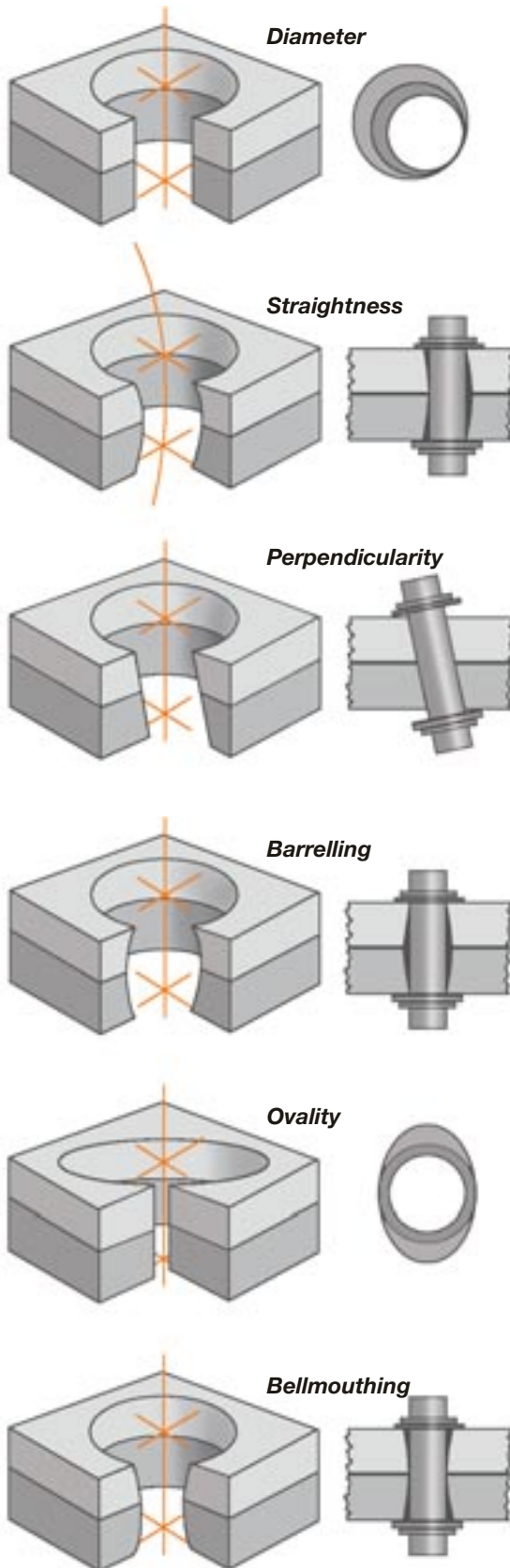

## Benefits of Proper Hole Preparation

### Improved Hole Quality

- Diameter tolerance
- Countersink depth tolerance
- Hole finish
- Hole straightness
- Lack of burrs
- No delamination in composites
- No fiber fraying in composites
- No metallurgical change from excess heat

### Lowered Cost Per Hole

- Decrease the drilling time
- Reduce the number of operations for a finished hole
- Combine drilling and countersinking into one operation
- Self clamping attachments minimize hole to hole time

### Reduced Inventory & Capital Investment

- Portable equipment eliminates expensive, large stationary machines
- Simultaneous drilling and countersinking reduces total equipment requirements
- Self clamping significantly reduces fixturing costs
- Modular designs reduce the number of complete backup units

### Reduced Safety Hazards

- Less operator contact
- Drill bit control through nosepieces and fixtured bushings
- All reactions of the drilling process are absorbed by the fixture and drilling equipment

# TRAINING

### ***Our Commitment To Your Success***

Our complete line of tools are carefully designed and built from the finest materials available in order to provide years of trouble free service. But, as with any piece of equipment, service problems can occur. All tools are designed to be easy to service...that is, of course, if you know what you're doing.

To facilitate quick repairs, and limit downtime...CooperTools conducts training seminars covering all aspects of every tool we make.

Introductory training seminars are designed to fully acquaint students with the entire line of tools and their fundamental operation. The emphasis is on thoroughly understanding each tool...its features, uses, and the best way to demonstrate the tool to a potential buyer.

Advanced training seminars, which are often tailored to individual needs, are designed to hone the skills of the experienced student. Hands-on experience, with an emphasis on troubleshooting and repairing, are the focus of this training.

For additional information on our training seminars, please call your local CooperTools Distributor.







## **Factory Certified Tool Service**

You can depend on Factory Certified Service Centers to provide the service your tools need.

CooperTools has strategically located Certified Service Centers throughout the U.S. These Centers are staffed with professional Tool Repair Technicians who provide complete and comprehensive repairs for **all** air tools, regardless of manufacture. And to be sure all repairs are done right the first time, the latest in testing equipment and inspection instruments are used.

Each tool repaired in one of the Factory Certified Service Centers is calibrated and tested to new tool standards, and carries the New Tool Warranty of Performance.

## **Free Repair Estimates**

The cost to repair your air tool is provided before any work is started. We think you should know in advance what to expect. Naturally, the repair estimates are free... with no obligation.



## **Tool Inspection Service**

Representatives from the Certified Service Center can help you improve your air tool utilization by providing a free, no-obligation survey of your present tooling. By identifying air tools in your plant that are worn and inefficient, the Factory Trained Servicemen can recommend appropriate repairs to help you reduce costly down-time and improve your man-hour productivity.



## **New Tool Warranty**

Because every Certified Service Center has all equipment necessary to repair and calibrate your tools, each tool that leaves our centers has a New Tool Warranty. You have our assurance that this tool will perform just like it did when it was new.

# Sales & Service Centers

---

NOTE: All locations may not service all products. Please contact the nearest Sales & Service Center for the appropriate facility to handle your service requirements.

## ATLANTA

**CooperTools  
Sales & Service Center**  
5600 Oakbrook Pkwy., Suite 140  
Norcross, GA 30093  
Tel: (770) 446-0368  
Fax: (770) 446-9360

## DALLAS

**CooperTools  
Sales & Service Center**  
1470 Post & Paddock  
Grand Prairie, TX 75050  
Tel: (972) 641-9563  
Fax: (972) 641-9674

## DETROIT

**CooperTools  
Sales & Service Center**  
4121 North Atlantic Blvd.  
Auburn Hills, MI 48326  
Tel: (248) 391-3700  
Fax: (248) 391-6295

## HOUSTON

**CooperTools  
Sales & Service Center**  
7007 Pinemont  
Houston, TX 77040  
Tel: (713) 460-7041  
Fax: (713) 462-0482

## LEXINGTON

**CooperTools**  
670 Industrial Drive  
Lexington, SC 29072  
Tel: (800) 845-5629  
Tel: (803) 359-1200  
Fax: (803) 359-0822

## LOS ANGELES

**CooperTools  
Sales & Service Center**  
2000 S. Santa Cruz Street  
Anaheim, CA 92805-6816  
Tel: (714) 712-5800  
Fax: (714) 712-5801

## SPRINGFIELD

**CooperTools  
Airetool Operation**  
*(Airetool products only)*  
302 South Center Street  
Springfield, OH 45506  
Tel: (937) 323-4981  
Tel: (877) 739-7263  
Fax: (937) 323-6524

## TULSA

**CooperTools  
Sales & Service Center**  
5415 S. 125th East Avenue  
Suite 202  
Tulsa, OK 74146  
Tel: (918) 250-9040  
Fax: (918) 252-5931

## BRAZIL

**Cooper Tools Industrial Ltda.**  
Av. Liberdade, 4055  
Zona Industrial - Iporanga  
18087-170 Sorocaba, SP Brazil  
Tel: (011) 55 15 238 3929  
Fax: (011) 55 15 228 3260

## CANADA

**CooperTools  
Sales & Service Center**  
6581 Kitimat Road Unit #10  
Mississauga, Ont. L5N 3T5  
Canada  
Tel: (905) 826-3000  
Fax: (905) 826-9443

## FRANCE

**CooperTools  
Recoules Operation**  
Zone Industrielle  
BP 28  
Avenue Maurice Chevalier  
77831 Ozoir-la-Ferrière Cedex  
France  
Tel: 011 33 1 4 43 22 00  
Fax: 011 33 1 60 18 55 01

## GERMANY

**Cooper Power Tools  
GmbH & Co.**  
Postfach 30  
D-73461 Westhausen  
Tel: +49 (0) 73 63-8 10  
Fax: +49 (0) 73 63-8 12 22

## MEXICO

**Cooper Power Tools  
de México S.A. de C.V.**  
Ave. San Andrés Atoto No. 165A  
Col. San Esteban  
Naucalpan, Edo. de México C.P.  
53550  
Tel: (011) 525 576-7955  
Fax: (011) 525 576-0096

## CooperTools Is On The Web!

CooperTools is pleased to unveil a complete resource for power tools on-line. [www.coopertools.com](http://www.coopertools.com) offers product information, service literature, brand catalogs, press releases and more. A dominant source of information, the CooperTools' web site is your source for application solutions on-line.



## Making your job easier is our goal!

You can access service literature anytime. Choose a category such as Assembly Tools or Material Removal Tools from the main menu and then click on the brand you're looking for. You'll be on your way to any current service literature you need, whether it's Doler, Quackenbush, Dotco or any of our power tools' brands.

Up-to-date product catalogs are also available online providing you with current information on our broad product line. Even Material Safety Data Sheets (M.S.D.S.) for Safety and Disposal Information are available on our website.



## It's simple!

Our *Customer Service* section provides you with information such as answers to frequently asked questions or contact phone numbers and addresses for your area of the country. You can learn more about CooperTools in the *About Us* section or browse through the *What's New* information to learn how CooperTools continues to be your source for solutions.



For even faster searches, you can go direct to a brand site by simply entering the brand name.

Entering [www.dolertools.com](http://www.dolertools.com) or [www.quackenbushtools.com](http://www.quackenbushtools.com) takes you directly to the brand site.



What is the future of [www.coopertools.com](http://www.coopertools.com)? A dynamic site continuing to focus on your need for up-to-date information on the latest CooperTools' offerings that you can access anytime you need...twenty-four hours a day, seven days a week!

# Warranty, Lubrication Products & Safety Recommendations

## Warranty

Cooper warrants products and parts sold by it, insofar as they are of its own manufacture, against defects of material and workmanship, under normal use and service in accordance with its written instructions, recommendations, and ratings for installation, operation, maintenance, and service of products, for a period of **ONE YEAR FROM THE DATE OF INITIAL USE, BUT IN NO EVENT SHALL THE WARRANTY EXCEED 24 MONTHS FROM DATE OF DELIVERY TO DISTRIBUTOR.** Proof of Purchase with shipment date must be furnished by the user to validate the warranty. This warranty applies only to products manufactured by Cooper and specifically excludes products manufactured by others. Products not manufactured by Cooper are warranted only to the extent and in the manner warranted to Cooper by the manufacturer and then only to

the extent Cooper is able to enforce such warranty. Cooper's warranty with respect to products manufactured by it is limited to the repair or replacement, as Cooper may elect, of any defective part regarding which the Distributor has given 5 days written notice from the discovery of such defect. Installation and transportation costs are not included. Cooper shall have the option of requiring the return to it of the defective material, transportation prepaid, for inspection. No allowance will be made for repairs without Cooper's approval. **COOPER MAKES NO OTHER WARRANTY OF ANY KIND WHATSOEVER, EXPRESSED OR IMPLIED, AND HEREBY DISCLAIMS ALL WARRANTIES OF MERCHANTABILITY AND FITNESS FOR A PARTICULAR PURPOSE.**

## Lubrication Products

CooperTools' products are classified as non-hazardous manufactured items, defined in the OSHA 1910.1200 Hazard Communication Standard as "Articles". These products, under conditions of normal use, do not release or cause exposure to a hazardous chemical.

Under normal conditions of use, lubrication products sold separately for or used within these tools should not cause an exposure hazard. Refer to the Material Safety Data Sheet (M.S.D.S.) for Safety and Disposal Information. M.S.D.S. sheets are available upon request from CooperTools or on our web-site at [www.coopertools.com](http://www.coopertools.com).

Cooper is also aware of, and complies with, the provisions

of section 611 amendments to the Clean Air Act of 1990. No ozone depleting chemicals have been used in the manufacture of our products.

If you resell or distribute these products, you have the responsibility for ensuring that the Material Safety Data Sheets are provided to the purchaser.

Proper lubrication is essential to the economical operation of pneumatic and electric tools. CooperTools perform better and their life is extended by using the recommended lubricants. All lubricants that are listed in the accessory section of this catalog have undergone extensive testing and are recommended for use with CooperTools products.

## Safety Recommendations – Safe Drilling Practices

For your safety and the safety of others, read and understand the safety recommendations and operating instructions supplied with the tool.

**Always wear personal protective equipment.**



For additional information on eye protection, refer to Federal OSHA Regulations, 29 CFR, Section 1910.133, Eye and Face Protection, and ANSI Z 87.1, Occupational and Educational Eye and Face Protection. This standard is available from the American National Standards Institute, Inc., 11 West 42nd Street, New York, NY 10036.

Hearing protection is recommended in high noise areas (above 85 dBA). Close proximity of additional tools, reflective surfaces, process noises, and resonant structures can substantially contribute to the sound level experienced by the operator. For additional information on hearing protection,



refer to Federal OSHA regulations, 29 CFR, Section 1910.95, Occupational Noise Exposure and American National Standards Institute, ANSI S12.6, Hearing Protectors.



Drilling operations may produce hazardous fumes and/or dust. To avoid adverse health effects utilize adequate ventilation and/or wear a respirator. Read the material safety data sheet of any cutting fluids or materials involved in the drilling process.

# Safety Recommendations – Safe Drilling Practices

Follow good machine shop practices. Rotating shafts and moving components entangle and entrap, and may result in serious injuries. Never wear long hair, loose fitting clothes, gloves, ties, or jewelry when working with or near a drill of any type.

**Safety Labels.** The safety labels found on our Advanced Drilling Equipment are essential parts of the product. Labels should not be removed. Labels should be checked periodically for legibility. Replace safety labels when missing or when the information can no longer be read. Replacement labels can be ordered using the part numbers found in each respective tool's Operating Instructions and Service Manual.

**WARNING** Some non-ferrous metal chips (or dusts) are combustible. Examples: Aluminum, magnesium, titanium, and zirconium. See the material safety data sheets for combustibility of materials drilled. Never collect spark generating material with combustible material. Examples: Collecting both steel and aluminum or steel and titanium.



Our Advanced Drilling Equipment tools are designed to operate on 90 psig (6.2 bar) air pressure. Excessive air pressure can increase the loads and stress on tool parts and drills, and may cause breakage. **Higher air pressure can also increase the sound level of the tool.** Installation of a filter-regulator-lubricator in the air supply line ahead of the tool is recommended. The use of a quick disconnect or self-relieving valve within reach of the user of the tool is highly recommended.

Before connecting the tool with a trigger to the air supply, check the throttle for proper operation (i.e. throttle valve moves freely and returns to closed position). Before removing a tool from service or changing drill bits, make sure the air line is shut off and drained of air by using the self-relieving valve. This will prevent the tool from operating if the throttle is accidentally engaged. Also, make sure the chuck key or drill drift is removed before operating.

**CAUTION** Cutting tools used with our Advanced Drilling Equipment tools are sharp. Handle them carefully to avoid injury.

**CAUTION** Before mounting any positive feed drill, check the means for mounting the drill to the tooling fixture or jig. Lock screws, lock liners, and bushings must be in good condition and securely installed. Before operating, be sure the nose piece is properly locked in the fixture. Positive feed drills can exert high torques and high thrust loads. If failure of the lock screws, lock liners, or drill bushing occurs, the drill may suddenly spin and back away from the drill fixture.



Our Advanced Drilling Equipment tools are often used with lubricant or cooling systems which must be properly maintained to avoid leakage. Failure to do so can result in serious injuries from slipping on oily surfaces.



Due to the multitude and variety of tooling applications, the user's methods engineering, standard tooling engineering, and/or safety engineering departments, etc., must consider any entrapment and entanglement hazards that may be associated with each specific application and provide adequate operator protection from inadvertent contact with any moving components. Spindle guards are available in one inch increments for all of our Advanced Drilling Equipment right angle drills, and should be used to cover any exposed spindle.



Keep fingers and hands away from the slots in the tool nose at all times. **Rapid spindle retraction occurs automatically on some models after drilling cycle and can be activated manually, even with the air supply disconnected, on other models.** Most nose pieces used with positive feed drills are slotted for visibility and access to the chuck and cutter. Because the spindle retracts at a much faster rate than it feeds, care should be taken to avoid entrapment.



The clamping and feed mechanisms of our self-colleting drills can move when air supply is connected or disconnected. To avoid injury, keep fingers and hands away from the clamping and feed mechanism of the tool when handling or operating. The clamping and feed mechanism of our nut plate drills is

# Safety Recommendations – Safe Drilling Practices

covered by a clear polycarbonate guard for visibility. The clamping and feed mechanism can also move when the air supply is connected or disconnected. To avoid injury, keep fingers and hands away from these areas when handling or operating these tools and **keep the guard in place**.

**WARNING** Before starting the tool, the collet and mandrel of our Advanced Drilling Equipment tools must be inserted into a properly sized pre-drilled hole of proper material thickness. An improperly sized pre-drilled hole prevents the mandrel from engaging the collet and could result in slippage of the tool. An improperly selected collet and mandrel can also result in slippage of the tool.

**WARNING**

**Repetitive work motions and /or vibration may cause injury to hands and arms.**

Use minimum hand grip force consistent with proper control and safe operation.  
Keep body and hands warm and dry.  
Avoid anything that inhibits blood circulation.  
Avoid continuous vibration exposure.  
Keep wrists straight.  
Avoid repeated bending of wrists and hands.

Some individuals may be susceptible to disorders of the hands and arms when performing tasks consisting of highly repetitive motions and/or exposure to extended vibration. Cumulative trauma disorders such as carpal tunnel syndrome and tendonitis can be caused or aggravated by repetitious, forceful exertions of the hands and arms. Vibration may contribute to a condition called Raynaud's Syndrome. These disorders develop gradually over a period of weeks, months, and years. It is presently unknown to what extent exposure to vibrations or repetitive motions may contribute to the disorders. Hereditary factors, vasculatory or circulatory problems, exposure to cold and dampness, diet, smoking and work practices are thought to contribute to the conditions.

Operators should be made aware of the following symptoms and warning signs so that a problem can be addressed before it becomes a debilitating injury. Any user suffering prolonged symptoms of tingling, numbness, blanching of fingers, clumsiness or weakened grip, nocturnal pain in the hand, or any other disorders of the shoulders, arms, wrists, or fingers is advised to consult a physician. If it is determined that the symptoms are job related or aggravated by movements and postures dictated by the job design, it may be necessary for the employer to take steps to prevent further occurrences. These steps might include, but are not limited to, repositioning the workpiece or redesigning the workstation, reassigning workers to other jobs, rotating jobs, changing work pace, and/or changing the type of tool used so as to minimize stress on the operator. Some tasks may require more than one type of tool to obtain the optimum operator/tool/task relationship.

The following suggestions will help reduce or moderate the effects of repetitive workmotions and/or extended vibration exposure:

- Use a minimum hand grip force consistent with proper control and safe operations.
- Keep body and hands warm and dry (cold weather is reported to be a major factor contributing to Raynaud's Syndrome)
- Avoid anything that inhibits blood circulation
  - Smoking Tobacco (another contributing factor)
  - Cold Temperatures
  - Certain Drugs
- Tasks should be performed in such a manner that the wrists are maintained in a neutral position, which is not flexed, hyperextended, or turned side to side
- Stressful postures should be avoided – select a tool appropriate for the job and work location
- Avoid highly repetitive movements of hands and wrists, and continuous vibration exposure (after each period of operation, exercise to increase blood circulation)
- Interrupt work, activities, or rotate jobs to provide periods free from repetitive work motions
- Keep tool well maintained and replace worn parts

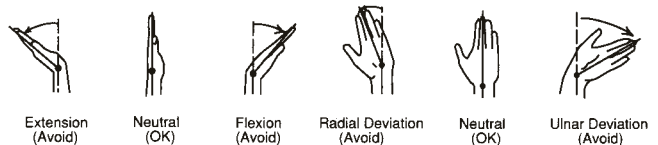

## Speed and Feed Selection Considerations

Because our Advanced Drilling Equipment tools are portable and generally hand-carried from one drill location to the next, every effort has been made to make them as compact and light-weight as possible without compromising the strength required to provide rugged durability and service. A wide selection of feeds and speeds are available to accommodate drilling of a variety of materials.

**CAUTION** Good machining practice is an integral part of obtaining optimum service life from the tool and the cutter. Selection of speeds and feeds must take into consideration workpiece material and hardness, cutter geometry and sharpness, and quality of lubrication.

Use of the highest feed rates at the lowest speeds in conjunction with very tough or hard materials will likely result in higher than normal maintenance. The exceptionally low speeds, obtained by high numerical gear reductions, can yield very high theoretical stall torque that far exceed the torque requirements of a well engineered drilling application. High loads imposed by feeds excessive for the material and cutter combination may result in damage.

# Conversion Table

## Torque – Air Pressure – Miscellaneous

TORQUE CONVERSION – IN. LBS. (NM)					
In.	Nm	In.	Nm	In.	Nm
5	0.6	50	5.7	140	15.8
10	1.1	60	6.8	150	17.0
15	1.7	70	7.9	160	18.1
20	2.3	80	9.0	170	19.2
25	2.8	90	10.2	180	20.3
30	3.4	100	11.3	190	21.5
35	4.0	110	12.4	200	22.6
40	4.5	120	13.6		
45	5.1	130	14.7		

TORQUE CONVERSION FACTORS		
To Convert	Into	Multiply By
Inch Pounds	Foot Pounds	0.0835
Inch Pounds	Newton meters	0.1130
Inch Pounds	Kg-meters	0.0115
Inch Pounds	Kg-Cm	1.1519
Foot Pounds	Inch Pounds	12.000
Foot Pounds	Newton meters	1.3560
Foot Pounds	Kg-meters	0.1382
Foot Pounds	Kg-Cm	13.8240
Newton Meters	Inch Pounds	8.8440
Newton Meters	Foot Pounds	0.7370
Newton Meters	Kg-meters	0.1020
Newton Meters	Kg-Cm	10.2000
Kg meters	Inch Pounds	86.8100
Kg meters	Foot Pounds	7.2340
Kg meters	Newton-meters	9.8040
Kg Cm	Inch Pounds	0.8681
Kg Cm	Foot Pounds	0.0723
Kg Cm	Newton-meters	0.0980

### Suggested Surface Speeds for High Speed Steel Drills\*

MATERIAL	S.F.M.
Alloy Steels – 300 to 4000 Brinell	20-30
Stainless Steels – Medium range	30-40
Automotive Steel Forgings and the like	40-50
Tool Steels Annealed – 90 to 1.20 Carbon	50-60
Steels – .40 to .50 Carbon	70-80
Steels – .20 to .30 Carbon (Machinery Steel)	80-110
Hard, Chilled Cast Iron	30-40
Medium Hard Cast Iron	70-110
Soft Cast Iron	100-150
Malleable Iron	80-90
Monel Metal	40-50
High Tensile Strength Bronze	70-150
Ordinary Brass and Bronze	200-300
Aluminum and its Common Alloys	250-400
Magnesium and its Common Alloys	250-400
Plastics – Common Types	100-150
Wood	300-400

\* Carbon Steel Drills should be operated at 40%–50% of the above speeds.

These speeds indicate the approximate range under normal conditions. For peak performance on individual jobs, adjustments may be required.

To convert surface feet per minute (SFM) into revolutions per minutes (RPM) use the following formula:

$$\text{RPM} = \frac{\text{SFM} \times 3.82}{\text{Diameter}}$$

Example: To drill 1/4" hole in aluminum:

$$\frac{300 \times 3.82}{.250} = 4.584 \text{ RPM}$$

Recommended Tool: Cleco 111 DO-50B

MISCELLANEOUS CONVERSION FACTORS		
To Convert	Into	Multiply By
Inches	Millimeters	25.4000
Millimeters	Inches	0.0394
Pounds	Kilograms	0.4536
Kilograms	Pounds	2.2050
psi	bar	0.069
bar	psi	14.5

AIR PRESSURE CONVERSION		
PSI	kPa*	Bar**
85	586	5.9
90	620	6.2
95	655	6.6
100	690	6.9
125	860	8.6

\* Preferred: Approximate to the nearest 5 kPa.

\*\* Approximate to the nearest 0.5 Bar.

Drill Diameter (inches)	Surface Speed, Feet per Minute											
	30	40	50	60	70	80	90	100	110	200	300	400

### Spindle Speeds, RPM

1/4	458	611	764	917	106=70	1222	1375	1528	1681	3056	4584	6111
5/16	367	489	611	733	856	976	1100	1222	1345	2445	3666	4888
3/8	306	407	509	611	713	815	917	1019	1120	2037	3056	4074
7/16	262	349	437	524	611	698	786	873	960	1746	2619	3492
1/2	229	306	382	458	535	611	688	764	840	1528	2282	3056

If there is a choice between tools of about the same speed but of different sizes, final selection is made by preference for a lighter-weight tool or one with more power to maintain speed under load.

# Conversion Table

Millimeter – Decimal – Fraction

mm	Dec.	in.	mm	Dec.	in.	mm	Dec.	in.	mm	Dec.	in.	mm	Dec.	in.
0.100	.0039		5.159	.2031	13/64	10.200	.4016		15.300	.6024		20.300	.7992	
0.200	.0079		5.200	.2047		10.300	.4055		15.400	.6063		20.400	.8031	
0.300	.0118		5.300	.2087		10.319	.4063	13/32	15.478	.6094	39/64	20.500	.8071	
0.397	.0156	1/64	5.400	.2126		10.400	.4094		15.500	.6102		20.600	.8110	
0.400	.0157		5.500	.2165		10.500	.4134		15.600	.6142		20.638	.8125	13/16
0.500	.0197		5.556	.2188	7/32	10.600	.4173		15.700	.6181		20.700	.8150	
0.600	.0236		5.600	.2205		10.700	.4219		15.800	.6220		20.800	.8189	
0.700	.0276		5.700	.2244		10.716	.4219	27/64	15.875	.6250	5/8	20.900	.8228	
0.794	.0313	1/32	5.800	.2283		10.800	.4252		15.900	.6250		21.000	.8268	
0.800	.0315		5.900	.2323		10.900	.4291		16.000	.6299		21.034	.8182	53/64
0.900	.0354		5.953	.2344	15/64	11.000	.4331		16.100	.6339		21.100	.8307	
1.000	.0394		6.000	.2362		11.100	.4370		16.200	.6378		21.200	.8307	
1.100	.0433		6.100	.2402		11.113	.4375	7/16	16.272	.6406	41/64	21.200	.8346	
1.191	.0469	3/64	6.200	.2441		11.200	.4409		16.300	.6417		21.300	.8386	
1.200	.0472		6.300	.2480		11.300	.4449		16.400	.6457		21.400	.8425	
1.300	.0512		6.350	.2500	1/4	11.400	.4488		16.500	.6496		21.431	.8438	27/32
1.400	.0551		6.400	.2520		11.500	.4528		16.600	.6535		21.500	.8465	
1.500	.0591		6.500	.2559		11.509	.4531	29/64	16.669	.6563	21/32	21.600	.8504	
1.588	.0625	1/16	6.600	.2598		11.600	.4567		16.700	.6575		21.700	.8543	
1.600	.0630		6.700	.2638		11.700	.4606		16.800	.6614		21.800	.8583	
1.700	.0669		6.747	.2656	17/64	11.800	.4646		16.900	.6654		21.828	.8594	55/94
1.800	.0709		6.800	.2677		11.900	.4685		17.000	.6693		21.900	.8622	
1.900	.0748		6.900	.2717		11.906	.4688	15/32	17.066	.6719	43/64	22.000	.8661	
1.984	.0781	5/64	7.000	.2756		12.000	.4724		17.100	.6732		22.100	.8701	
2.000	.0878		7.100	.2795		12.100	.4764		17.200	.6772		22.200	.8740	
2.100	.0827		7.144	.2813	9/32	12.200	.4803		17.300	.6811		22.225	.8750	7/8
2.200	.0866		7.200	.2835		12.300	.4843		17.400	.6850		22.300	.8780	
2.300	.0906		7.300	.2874		12.303	.4844	31/64	17.463	.6875	11/16	22.400	.8819	
2.381	.0938	3/32	7.400	.2913		12.400	.4882		17.500	.6890		22.500	.8858	
2.400	.0945		7.500	.2953		12.500	.4921		17.600	.6929		22.600	.8898	
2.500	.0984		7.541	.2969	19/64	12.600	.4961		17.700	.6968		22.622	.8906	57/64
2.600	.1024		7.600	.2992		12.700	.5000	1/2	17.800	.7008		22.700	.8937	
2.700	.1063		7.700	.3031		12.800	.5039		17.859	.7031	45/64	22.800	.8976	
2.778	.1094	7/64	7.800	.3071		12.900	.5079		17.900	.7047		22.900	.9016	
2.800	.1102		7.900	.3110		13.000	.5118		18.000	.7087		23.000	.9055	
2.900	.1142		7.938	.3125	5/16	13.097	.5156	33/64	18.100	.7126		23.019	.9063	29/32
3.000	.1181		8.000	.3150		13.100	.5157		18.200	.7165		23.100	.9094	
3.100	.1220		8.100	.3189		13.200	.5197		18.256	.7188	23/32	23.200	.9134	
3.175	.1250	1/8	8.200	.3228		13.300	.5236		18.300	.7205		23.300	.9173	
3.200	.1260		8.300	.3268		13.400	.5276		18.400	.7244		23.400	.9213	
3.300	.1299		8.334	.3281	21/64	13.494	.5313	17/32	18.500	.7283		23.416	.9219	59/64
3.400	.1339		8.400	.3307		13.500	.5315		18.600	.7323		23.500	.9252	
3.500	.1378		8.500	.3346		13.600	.5354		18.653	.7344	47/64	23.600	.9291	
3.572	.1406	9/64	8.600	.3386		13.700	.5394		18.700	.7362		23.700	.9331	
3.600	.1417		8.700	.3425		13.800	.5433		18.800	.7402		23.800	.9370	
3.700	.1457		8.731	.3438	11/32	13.891	.5469	35/64	18.900	.7441		23.900	.9409	
3.800	.1496		8.800	.3465		13.900	.5472		19.000	.7480		24.000	.9449	
3.900	.1535		8.900	.3504		14.000	.5512		19.050	.7500	3/4	24.100	.9488	
3.969	.1563	5/32	9.000	.3543		14.100	.5551		19.100	.7520		24.200	.9528	
4.000	.1575		9.100	.3583		14.200	.5591		19.200	.7559		24.209	.9531	61/64
4.100	.1624		9.128	.3594	23/64	14.288	.5625	9/16	19.300	.7598		24.300	.9567	
4.200	.1654		9.200	.3622		14.300	.5630		19.400	.7638		24.400	.9606	
4.300	.1693		9.300	.3661		14.400	.5669		19.447	.7656	49/64	24.500	.9646	
4.366	.1719	11/64	9.400	.3701		14.500	.5709		19.500	.7677		24.600	.9685	
4.400	.732		9.500	.3740		14.600	.5748		19.600	.7717		24.606	.9688	31/32
4.500	.1772		9.525	.3750	3/8	14.684	.5781	37/64	19.700	.7756		24.700	.9724	
4.600	.1811		9.600	.3780		14.700	.5787		19.800	.7795		24.800	.9764	
4.700	.1850		9.700	.3819		14.800	.5827		19.844	.7813	25/32	24.900	.9803	
4.763	.1875	3/16	9.800	.3858		14.900	.5866		19.900	.7835		25.000	.9843	
4.800	.1890		9.900	.3898		15.000	.5906		20.000	.7874		25.003	.9844	63/64
4.900	.1929		9.922	.3902	25/64	15.081	.5938	19/32	20.100	.7913		25.100	.9882	
5.000	.1969		10.000	.3937		15.100	.5945		20.200	.7953		25.200	.9921	
5.100	.2008		10.100	.3976		15.200	.5984		20.241	.7969	51/64	25.300	.9961	
												25.400	1.000	1



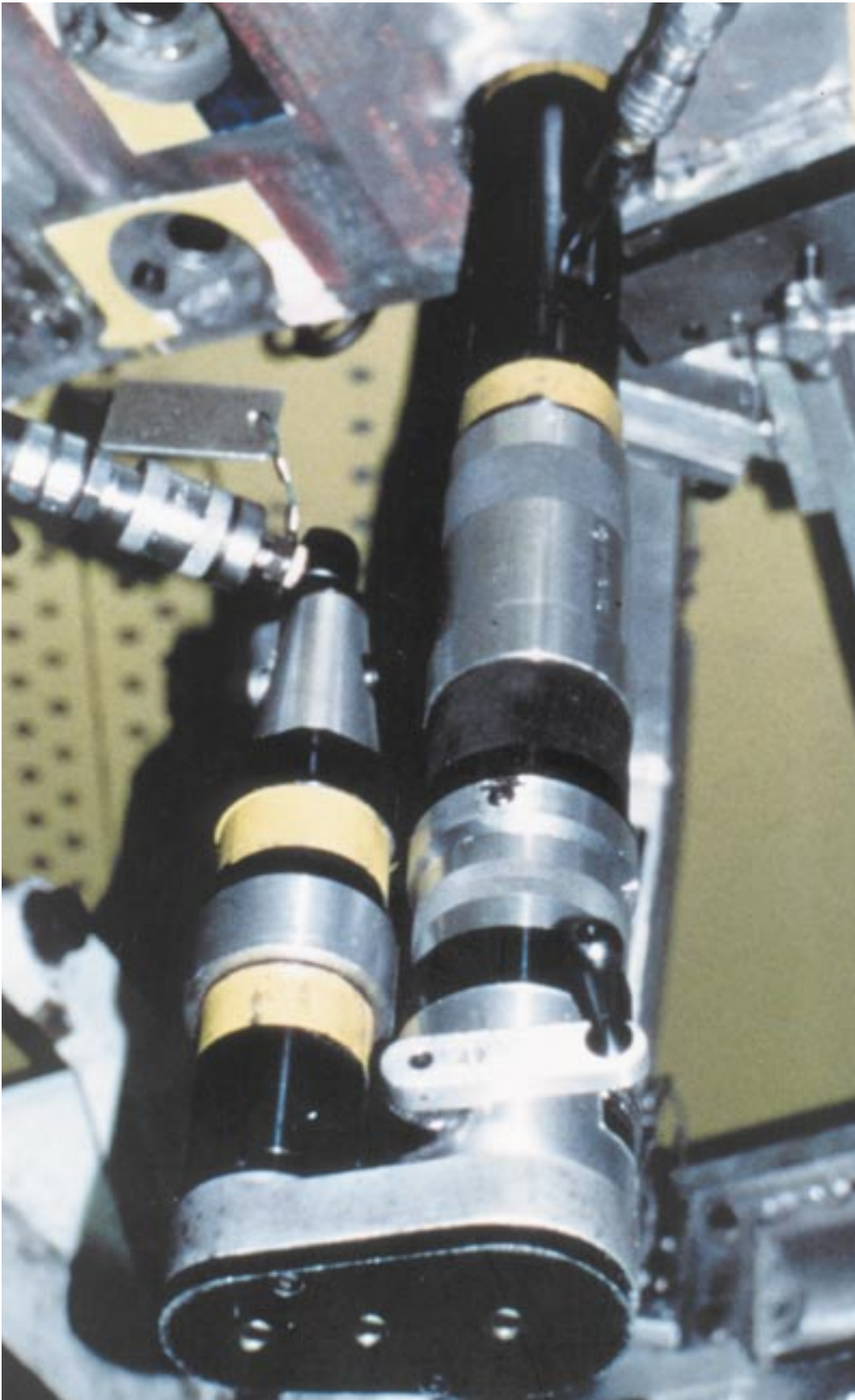

# Introduction

## In-Line Positive Feed Tools

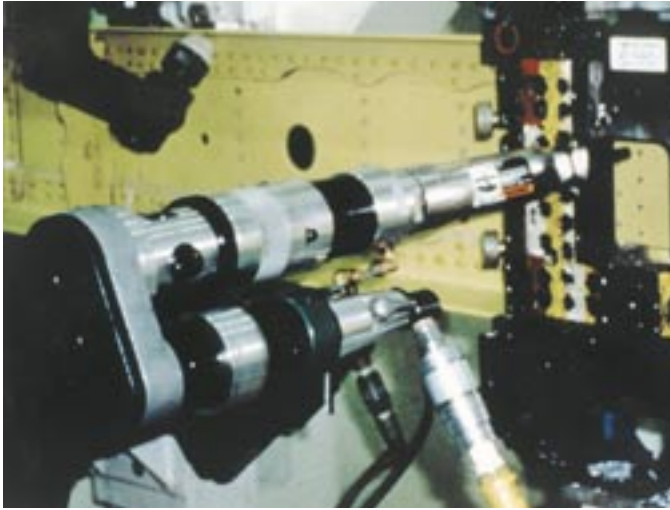

Our positive feed drill motors are available in piggyback, in-line and right angle configurations (please see the following section for right angle tools).

In general, positive feed drills are used for the large holes and heavy structures in the aircraft such as the spars ribs, landing gear, wings and fuselage.

A positive feed drill will advance the cutter at a fixed distance in relation to the revolution of the cutter. This is true regardless of the application.

Since the cutter advances a precise distance with each revolution, the cutter does not rotate without cutting. This reduces heat and deformation, resulting in less chance of the material work hardening.

Another key benefit delivered by these drills is that surge at breakthrough is virtually eliminated. Because there is no surge of the cutter on the exit side burrs are reduced or eliminated.

These drills range in stroke from 1.25" to 7.50". They may be used on all types of material, and can drill holes from .125" to 2.50" in diameter in aluminum.

Our in-line drills are available in either a straight or piggy back design, and both are advantageous in tight operating circumstances in which a right angle tool might have clearance concerns.

Many of the accessories for our in-line and right angle tools are interchangeable, such as chucks, nose pieces, motors and gears.

## How Positive Feed Drills Operate

Our in-line positive feed drills use two interconnected mechanisms: one to control the spindle rotation and one that controls the advancement or feed rate of the spindle.

The tool spindle is driven rotationally through an internal spline by a drive shaft ① connected directly to the motor through gearing. When the motor is

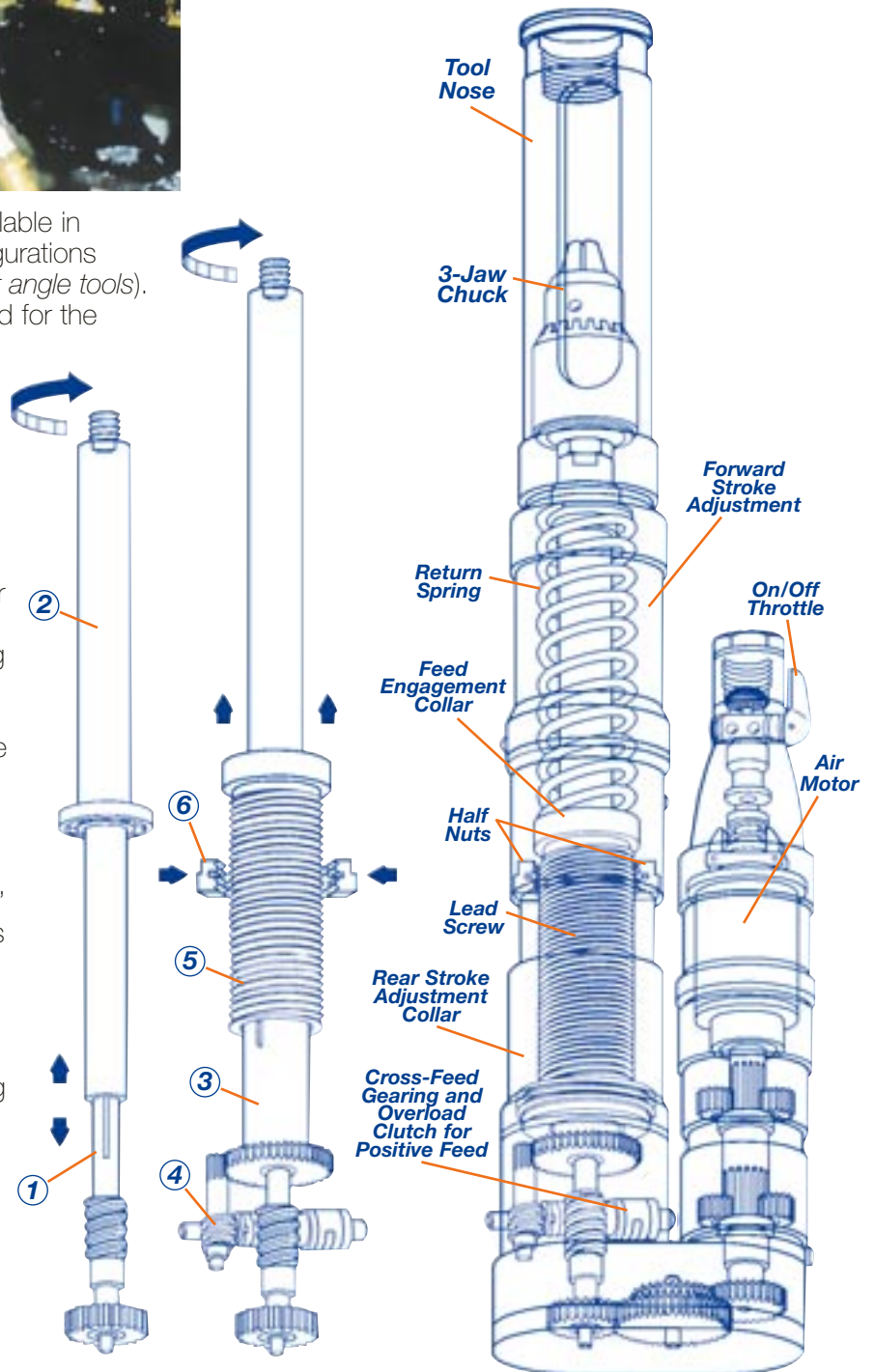

turned on, the spindle will rotate at a speed determined by the motor and gearing. The spindle ② rotates with the drive shaft, yet is free to slide or telescope axially.

Surrounding part of the spindle is the lead screw driver ③ that has a gear affixed to one end. The gear on the lead screw driver is connected to the motor gearing by a worm and cross shaft arrangement ④ and turns the lead screw driver at a fixed ratio with respect to the spindle. The lead screw driver rotates when the motor is turned on, but cannot move axially.

The lead screw ⑤ telescopes over the lead screw driver. The lead screw is internally splined to the lead screw driver so that it rotates with it while being free to slide axially. The lead screw will rotate any time the motor is turned on, but not move axially until the feed is engaged.

The positive feed is accomplished by engaging a pair of half nuts ⑥ (threaded nuts which have been sectioned) with the lead screw by rotating the feed engagement collar. The half nuts are held stationary by the housing. With the lead screw rotating and the half nuts engaged, the lead screw will advance and push the spindle forward.

Since both the feed mechanism and spindle rotation mechanism are driven from one source, a fixed rate of spindle advancement is achieved for each rotation of the spindle.

When the spindle has advanced to the predetermined depth, the retract stop is tripped, shifting the feed collar. This action releases the half nuts, and the spindle and lead screw are returned to the starting position ready for the next drilling cycle.

## Taper-Lok Fixturing

Customized fixtures are constructed to accept Taper-Lok Bushing Tips. Advanced Drilling Equipment tools with the Bushing Tips are inserted into the fixture, twisted and cam-locked into place.

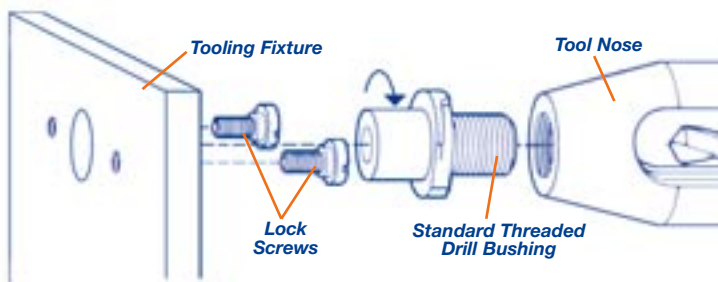

The Bushing Tip's tapered flanges fit under the shoulder of lock screws in the fixture. The Bushing Tip holds the tool in alignment and absorbs the thrust and torque of drilling. At the completion of the drilling cycle, the tools is rotated to unlock, withdrawn from the fixture and moved to the next position.

Several different types of Taper-Lok Fixturing are available. The following are the most common.

### Lock Liners

Method for mounting to a fixture. A hole is bored in the jig to accommodate the lock liner bushing. The lock ring holds the lock liner bushing in position in the jig.

### Direct Mounting

The Serrated Liner is used in potted or cast-in-place installations.

### Direct Mounting

Most common mounting method has lock screws mounted directly into the fixture plate. The shank of the drill bushing tip fits directly into a bored hole in the fixture plate.

### Lock Strip

This method for closely spaced holes employs a lock strip along each side of the row of holes in the fixture plate. The flanges on the Drill Bushing Tip lock under the extended edges of the lock strip.

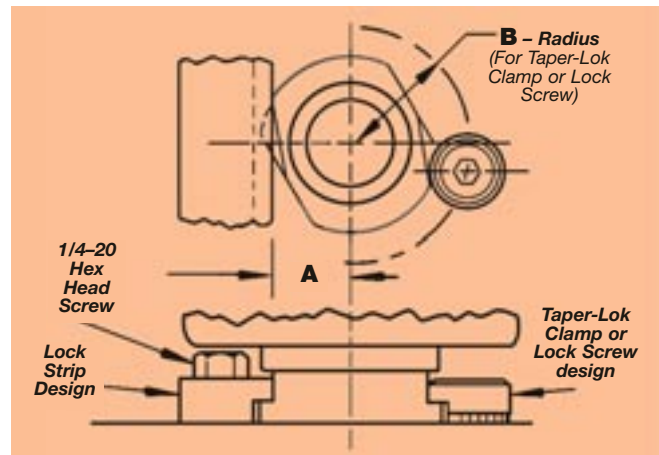

## Location Data for Taper-Lok Clamp, Lock Screw, and Lock Strip Mounting

Drill Bushing Tip Series	A	B	Tool Nose Thread (I.D.)
21000	.312	.625	3/4-16
22000	.609	.922	1-14
23000	.734	1.047	1 1/4-12
24000	.859	1.172	1 1/2-12
25000	None	1.562	2-16

## QUACKENBUSH™

### 15QD-S125 Series

**Capacity:**

- Aluminum – .375" (9.5mm)
- Titanium – .3125" (7.9mm)
- Steel – .3125" (7.9mm)

**Stroke:**

- Max – 1.25" (32mm)
- Min. – .0625" (2mm)

- 15 series motor develops 1.0 nominal horsepower.
- Positive mechanical feed provides fixed rate of feed with respect to spindle rotation.
- Drill spindle returns to starting position by manually rotating feed engagement collar.
- Starting position of drill may be adjusted by rotating rear stroke adjustment collar.
- Spindle feed is activated by manually rotating feed engagement collar.
- Overload clutch protects feed mechanism.



15QDB-S125

15QD-S125

Model	Motor Configuration	Maximum Stroke		Weight		Spindle Speeds	Feed Per Revolution	Chuck Capacity	Inlet	Minimum Hose Size
		in.	mm	lbs	kg					
15QD-S125	Straight	1.25	32	7	3.18	160, 250, 400, 800, 1400, 2000, 3000	.0005, .001, .002, .003, .004, .006, .008	.3125"	.375" NPT	.375"
15QB-S125	Piggy Back	1.25	32	7	3.18	160, 250, 400, 800, 1400, 2000, 3000	.0005, .001, .002, .003, .004, .006, .008	.3125"	.375" NPT	.375"

**STANDARD EQUIPMENT:**  
3 Jaw Chuck 849108 and Key 849120.

**NOTE:**  
Specify TOOL NOSE when ordering. Standard Noses page 1-5.  
Rated tool performance at 90 PSIG measured at tool inlet with motor running.  
When selecting speeds and feeds, see page I-5.  
SEE PAGES I-11-I-13 FOR SAFETY PRECAUTIONS.

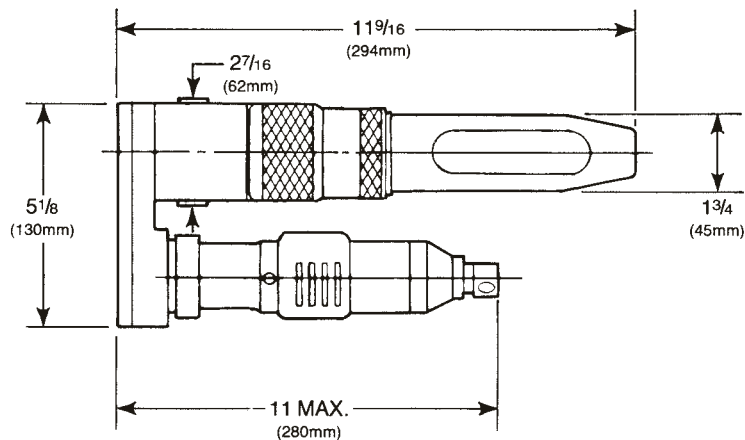
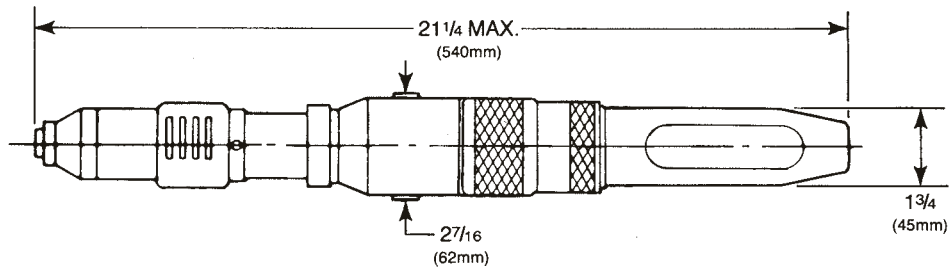

### ALUMINUM TOOL NOSE

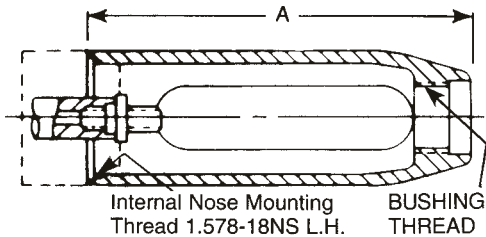

Bushing Thread	Length A	Part Number
.75-16LH	.3125 (132mm)	619143
1 -14LH	5.4375 (138mm)	619142
1.25-12LH	5.4375 (138mm)	619271

### 3-JAW CHUCK

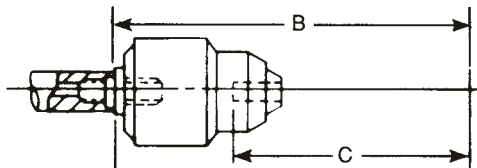

Bushing Thread	Dimension B	Dimension C	Desc.	Part Number
.75-16LH	4.625 (118mm)	3.3125 (84mm)	.375" Chuck	849108
1 -14LH	4.875 (124mm)	3.5625 (90mm)	Key	849120
1.25-12LH	4.875 (124mm)	3.5625 (90mm)		

### FLUID CHUCK

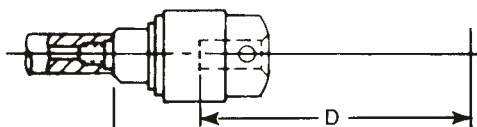

Bushing Thread	Dim. D Side Feed	Dim. D End Feed	Part Number*
.75-16LH	4.0938 (104mm)	3.3125 (84mm)	
1 -14LH	4.3438 (111mm)	3.5625 (90mm)	
1.25-12LH	4.3438 (111mm)	3.5625 (90mm)	

\*See page 1-37 for Selection and Part Number

### MORSE TAPER ADAPTER

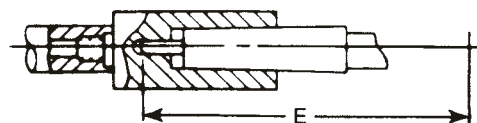

Bushing Thread	Dim. E - No. 1 MT 613542	Dim. E - No. 2 MT 612934
.75-16LH	4.0625 (103mm)	4.2188 (107mm)
1 -14LH	4.1563 (110mm)	4.4688 (114mm)
1.25-12LH	4.1563 (110mm)	4.4688 (114mm)

## QUACKENBUSH™

### 15QDA-S150B Semi-Automatic Series

**Capacity:**

Aluminum – .375" (9.5mm)

Titanium – .3125" (7.9mm)

Steel – .3125" (7.9mm)

**Stroke:**

Max – 1.5" (38mm)

Min. – .5625" (14mm)

- 15 series motor develops 1.0 nominal horsepower.
- Semi-automatic operation.
- When throttle is activated, the spindle rotates and feed mechanism engages automatically
- Upon completion of drilling cycle, the spindle returns to starting position and continues to rotate until throttle is turned off.
- Length of stroke can be adjusted forward and rear.
- Overload clutch protects feed mechanism.



Model	Motor Configuration	Maximum Stroke		Weight		Spindle Speeds	Feed Per Revolution	Chuck Capacity	Inlet	Minimum Hose Size
		in.	mm	lbs	kg					
15QDA-S150B	Straight	1.5"	38	10	4.53	160, 250, 400, 800, 1400, 2000, 3000	.0005, .001, .002, .003, .004, .006, .008	.375"	.375" NPT	.375"
15QDAB-S150B	Piggy Back	1.5"	38	10	4.53	160, 250, 400, 800, 1400, 2000, 3000	.0005, .001, .002, .003, .004, .006, .008	.375"	.375" NPT	.375"

**STANDARD EQUIPMENT:**  
 3 Jaw Chuck 614929 and Key 849123;  
 Forward Stroke Adjustment Wrench 614190.

**NOTE:**  
 Specify TOOL NOSE when ordering. Standard Noses page 1-7.  
 Rated tool performance at 90 PSIG measured at tool inlet with motor running.  
 When selecting speeds and feeds, see page I-5.  
 SEE PAGES I-11-I-13 FOR SAFETY PRECAUTIONS.

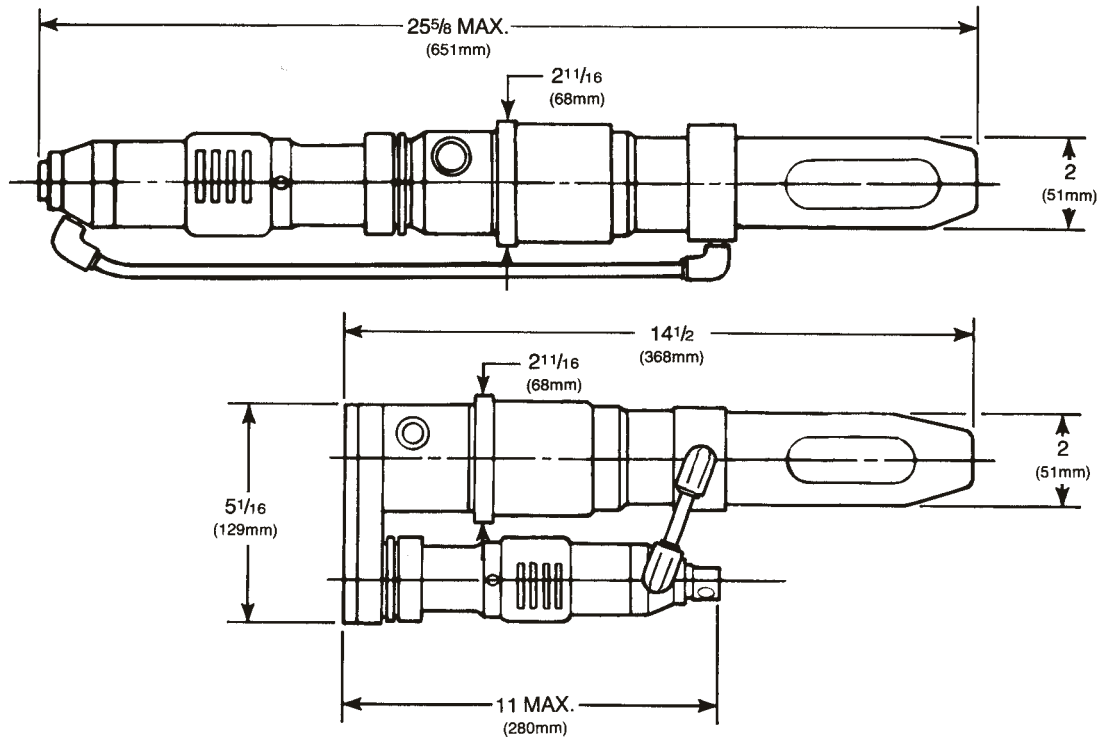

### ALUMINUM TOOL NOSE

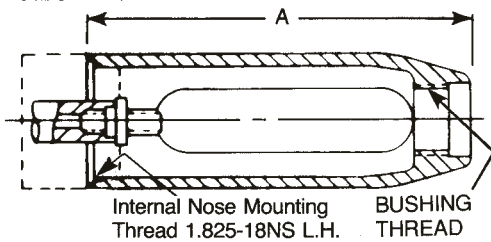

Bushing Thread	Length A	Part Number
.75 - 16LH	5.1875 (132mm)	619662
1 -14LH	5.4375 (138mm)	619683
1.25 -12LH	5.4375 (138mm)	619704

### 3-JAW CHUCK

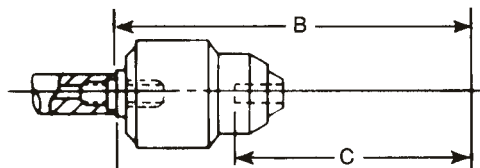

Bushing Thread	Dimension B	Dimension C	Desc.	Part Number
.75 - 16LH	5 (127mm)	3.5625 (90mm)	.375 Chuck	614929
1 -14LH	5.25 (134mm)	3.7813 (96mm)	Key	849123
1.25 -12LH	5.25 (134mm)	3.7813 (96mm)		

### FLUID CHUCK

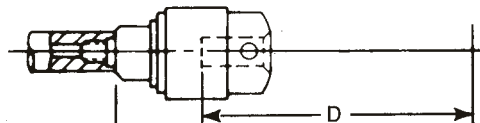

Bushing Thread	Dim. D Side Feed	Dim. D End Feed	Part Number*
.75 - 16LH	4.5 (114mm)	3.6875 (94mm)	
1 -14LH	4.7188 (120mm)	3.9375 (100mm)	
1.25 -12LH	4.7188 (120mm)	3.9375 (100mm)	

\*See page 1-37 for Selection and Part Number

### MORSE TAPER ADAPTER

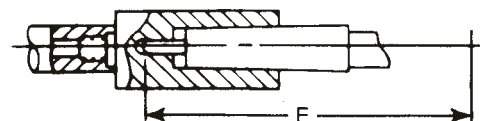

Bushing Thread	Dim. E - No. 1 MT 613542	Dim. E - No. 2 MT 612934
.75 - 16LH	4.4688 (113mm)	4.5938 (117mm)
1 -14LH	4.7188 (119mm)	4.8438 (123mm)
1.25 -12LH	4.7188 (119mm)	4.8438 (123mm)

## QUACKENBUSH™

### 158QGDA-S150B Semi-Automatic Series

**Capacity:**

- Aluminum – .375" (9.5mm)
- Titanium – .3125" (7.9mm)
- Steel – .3125" (7.9mm)

**Stroke:**

- Max – 1.5" (38mm)
- Min. – .5625" (14mm)

- 158 series motor develops 1.6 nominal horsepower.
- Available in straight and piggy-back models with fixed and variable speed motors.
- Semi-automatic operation.
- When throttle is activated, the spindle rotates and feed mechanism engages automatically.
- Upon completion of drilling cycle, the spindle returns to starting position and continues to rotate until throttle is turned off.
- Length of stroke can be adjusted forward and rear.
- Overload clutch protects feed mechanism.



158QGDAB-S150B

158QGDA-S150B

Model	Motor Configuration	Maximum Stroke		Weight		Spindle Speeds	Feed Per Revolution	Chuck Capacity	Inlet	Minimum Hose Size
		in.	mm	lbs	kg					
158QGDA-S150B	Straight	1.5"	38	12	5.44	95, 135, 165, 190 215, 245, 265, 350, 380, 420, 445, 525, 700, 750, 850, 900 1100, 1450, 1500, 1745 1800, 2175, 2900, 3600	.0005, .001, .002, .003, .004, .006, .008	.375"	.375" NPT	.375"
158QGDAB-S150B	Piggy Back	1.5"	38	12	5.44	55, 80, 95, 110, 125, 135, 150, 185, 250, 265, 310, 320, 400, 450, 535, 540, 640, 660, 900, 1100, 1460 1740, 2100, 2870, 3440	.0005, .001, .002, .003, .004, .006, .008	.375"	.375" NPT	.375"
158QGDABV-S150B VARIABLE SPEED	Piggy Back	1.5"	38	12	5.44	125/310, 265/640 450/1100, 1460/3440	.0005, .001, .002, .003, .004, .006,	.375"	.375" NPT	.375"

**STANDARD EQUIPMENT:**  
3 Jaw Chuck 614929 and Key 849123.  
Forward Stroke Adjustment Wrench 614190.

**NOTE:**  
Specify TOOL NOSE when ordering. Standard Noses page 1-9.  
Rated tool performance at 90 PSIG measured at tool inlet with motor running.  
When selecting speeds and feeds, see page I-5.  
SEE PAGES I-11-I-13 FOR SAFETY PRECAUTIONS.



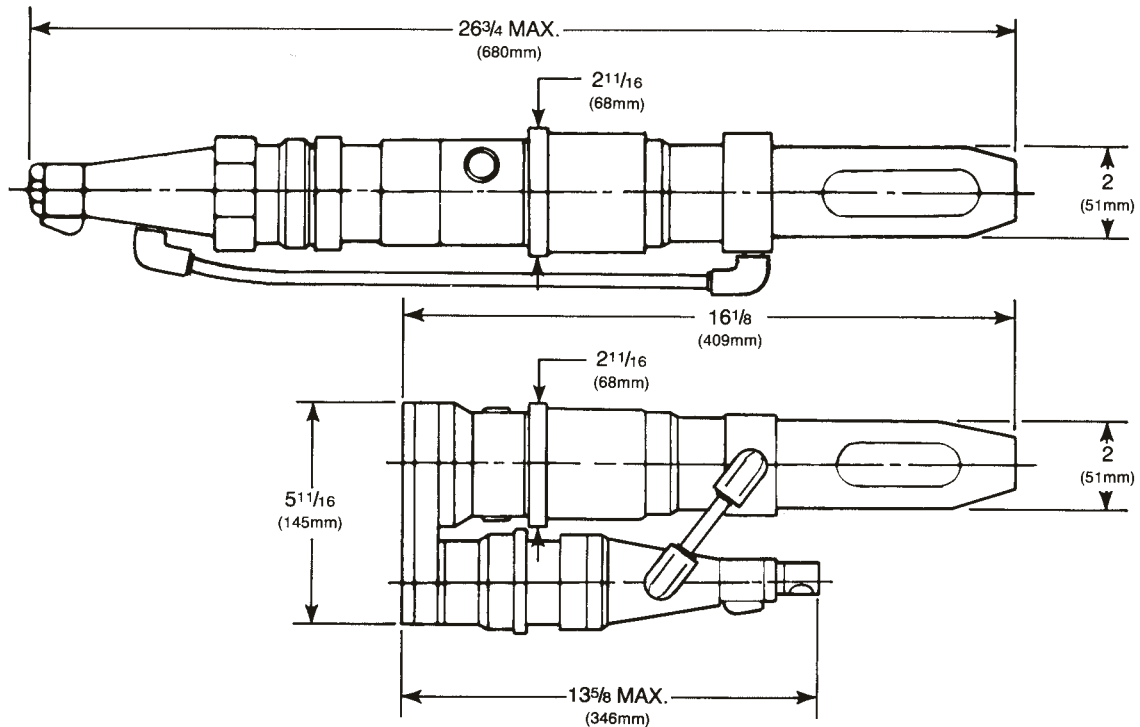

### ALUMINUM TOOL NOSE

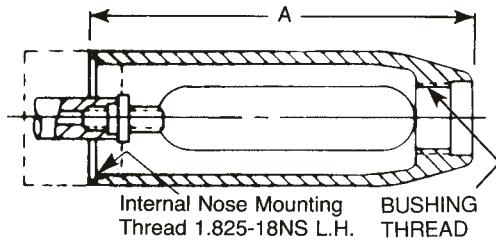

Bushing Thread	Length A	Part Number
.75 - 16LH	5.625 (143mm)	619662
1 -14LH	5.875 (149mm)	619683
1.25 -12LH	5.875 (149mm)	619704

### 3-JAW CHUCK

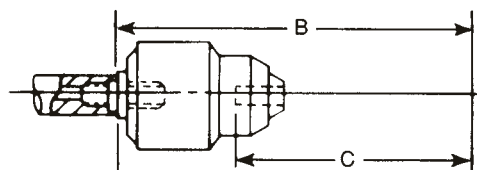

Bushing Thread	Dimension B	Dimension C	Desc.	Part Number
.75 - 16LH	5 (127mm)	3.5625 (90mm)	.375 Chuck	614929
1 -14LH	5.25 (134mm)	3.7813 (96mm)	Key	849123
1.25 -12LH	5.25 (134mm)	3.7813 (96mm)		

### FLUID CHUCK

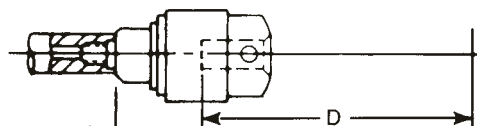

Bushing Thread	Dim. D Side Feed	Dim. D End Feed	Part Number*
.75 - 16LH	4.5 (114mm)	3.6875 (94mm)	
1 -14LH	4.7188 (120mm)	3.9375 (100mm)	
1.25 -12LH	4.7188 (120mm)	3.9375 (100mm)	

\*See page 1-37 for Selection and Part Number

### MORSE TAPER ADAPTER

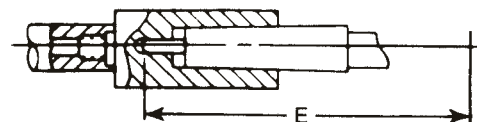

Bushing Thread	Dim. E - No. 1 MT 613542	Dim. E - No. 2 MT 612934
.75 - 16LH	4.4688 (113mm)	4.5938 (117mm)
1 -14LH	4.7188 (119mm)	4.8438 (123mm)
1.25 -12LH	4.7188 (119mm)	4.8438 (123mm)

## QUACKENBUSH™

### 158QGD-S265 Series

**Capacity:**

Aluminum – .5" (12.7mm)

Titanium – .375" (9.5mm)

Steel – .375" (9.5mm)

**Stroke:**

Max – 2.625" (67mm)

Min. – .0625" (2mm)

- 158 series motor develops 1.6 nominal horsepower.
- Available in single governed speed, variable speed, straight and piggy-back configurations.
- Spindle feed is activated by manually rotating feed engagement collar.
- Feed releases automatically at end of stroke and the spindle continues to rotate. Drill spindle returns to starting position by manually rotating feed engagement collar.
- Starting position of drill may be adjusted by rotating rear stroke adjustment collar.
- Overload clutch protects feed mechanism.



158QGDB-S265

Model	Motor Configuration	Maximum Stroke		Weight		Spindle Speeds	Feed Per Revolution	Chuck Capacity	Inlet	Minimum Hose Size
		in.	mm	lbs	kg					
158QGD-S265	Straight	2.625"	67	12.5	5.67	175, 215, 265, 350, 380, 420, 445, 525, 700, 750, 850, 900, 1100, 1450, 1500, 1745, 1800, 2175, 2900, 3600	.0005, .001, .002, .003, .004, .006, .008	.375"	.375" NPT	.5"
15QGDB-S265	Piggy Back	2.625"	67	12.5	5.67	125, 150, 185, 250, 265, 320, 400, 450, 535, 540, 640, 660, 900, 1100, 1460, 1740, 2100, 2870, 3440	.0005, .001, .002, .003, .004, .006, .008	.375"	.375" NPT	.5"
158QGDV-S265 Variable Speed	Straight	2.625"	67	12.5	5.67	175/445, 350/850, 750/1800, 1450/3600	.0005, .001, .002, .003, .004, .006, .008	.375"	.375" NPT	.5"
158QGDBV-S265 Variable Speed	Piggy Back	2.625"	67	12.5	5.67	125/310, 265/640, 450/1100, 1460/3440	.0005, .001, .002, .003, .004, .006, .008	.375"	.375" NPT	.5"

**STANDARD EQUIPMENT:**  
3 Jaw Chuck 849103 and Key 849123.

**NOTE:**  
Specify TOOL NOSE when ordering. Standard Noses page 1-11.  
Rated tool performance at 90 PSIG measured at tool inlet with motor running.  
When selecting speeds and feeds, see page I-5.  
SEE PAGES I-11-I-13 FOR SAFETY PRECAUTIONS.

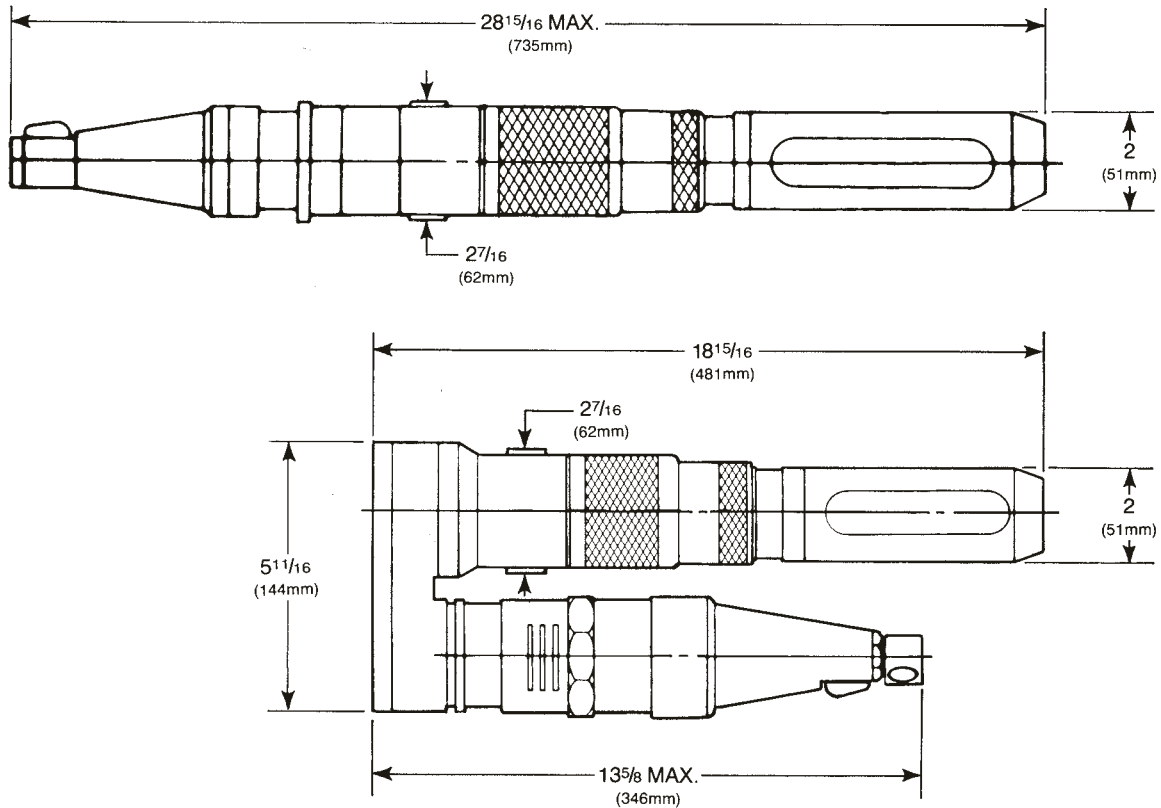

### ALUMINUM TOOL NOSE

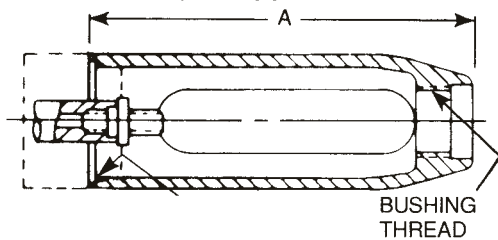

Bushing Thread	Length A	Part Number
.75 - 16LH	6.875 (175mm)	619954
1 -14LH	7.125 (181mm)	619955
1.25 -12LH	7.125 (181mm)	619953

### 3-JAW CHUCK

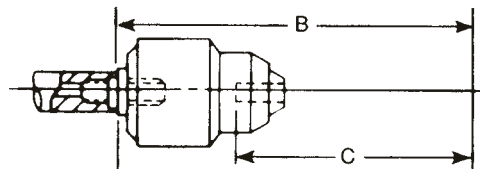

Bushing Thread	Dimension B	Dimension C	Desc.	Part Number
.75 - 16LH	6 (153mm)	4.5313 (115mm)	.375" Chuck	849103
1 -14LH	6.25 (159mm)	5.75 (144mm)	Key	849123
1.25 -12LH	6.35 (159mm)	5.75 (144mm)		

### FLUID CHUCK

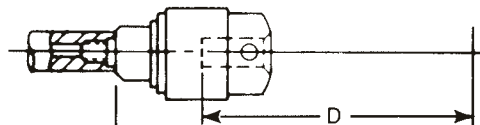

Bushing Thread	Dim. D Side Feed	Dim. D End Feed	Part Number*
.75 - 16LH	5.4688 (139mm)	4.6875 (119mm)	
1 -14LH	5.7188 (145mm)	4.9375 (125mm)	
1.25 -12LH	5.7188 (145mm)	4.9375 (125mm)	

\*See page 1-37 for Selection and Part Number

### MORSE TAPER ADAPTER

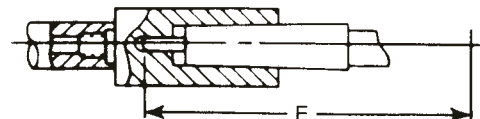

Bushing Thread	Dim. E - No. 1 MT 613542	Dim. E - No. 2 MT 612934
.75 - 16LH	5.4688 <sup>15</sup> / <sub>32</sub> (138mm)	5.625 (142mm)
1 -14LH	5.7188 <sup>23</sup> / <sub>32</sub> (145mm)	5.8438 (148mm)
1.25 -12LH	5.7188 <sup>23</sup> / <sub>32</sub> (145mm)	5.8438 (148mm)

## QUACKENBUSH™

### 15QDA-S275B Semi-Automatic Series

**Capacity:**

- Aluminum – .375" (9.5mm)
- Titanium – .3125" (7.9mm)
- Steel – .3125" (7.9mm)

**Stroke:**

- Max – 2.75" (70mm)
- Min. – .625" (16mm)

- 15 series motor develops 1.0 nominal horsepower.
- Semi-automatic operation.
- When throttle is activated, the spindle rotates and feed mechanism engages automatically
- Upon completion of drilling cycle, the spindle returns to starting position and continues to rotate until throttle is turned off.
- Length of stroke can be adjusted forward and rear.
- Overload clutch protects feed mechanism.



Model	Motor Configuration	Maximum Stroke		Weight		Spindle Speeds	Feed Per Revolution	Chuck Capacity	Inlet	Minimum Hose Size
		in.	mm	lbs	kg					
15QDA-S275B	Straight	2.75"	70	10	4.53	160, 250, 400, 800, 1400, 2000, 3000	.0005, .001, .002, .003, .004, .006, .008	.375"	.375" NPT	.375"
15QDAB-S275B	Piggy Back	2.75"	70	10.5	4.76	160, 250, 400, 800, 1400, 2000, 3000	.0005, .001, .002, .003, .004, .006, .008	.375"	.375" NPT	.375"

**STANDARD EQUIPMENT:**  
 3 Jaw Chuck 614929 and Key 849123;  
 Forward Stroke Adjustment Wrench 614190.

**NOTE:**  
 Specify TOOL NOSE when ordering. Standard Noses page 1-13.  
 Rated tool performance at 90 PSIG measured at tool inlet with motor running.  
 When selecting speeds and feeds, see page I-5.  
 SEE PAGES I-11-I-13 FOR SAFETY PRECAUTIONS.

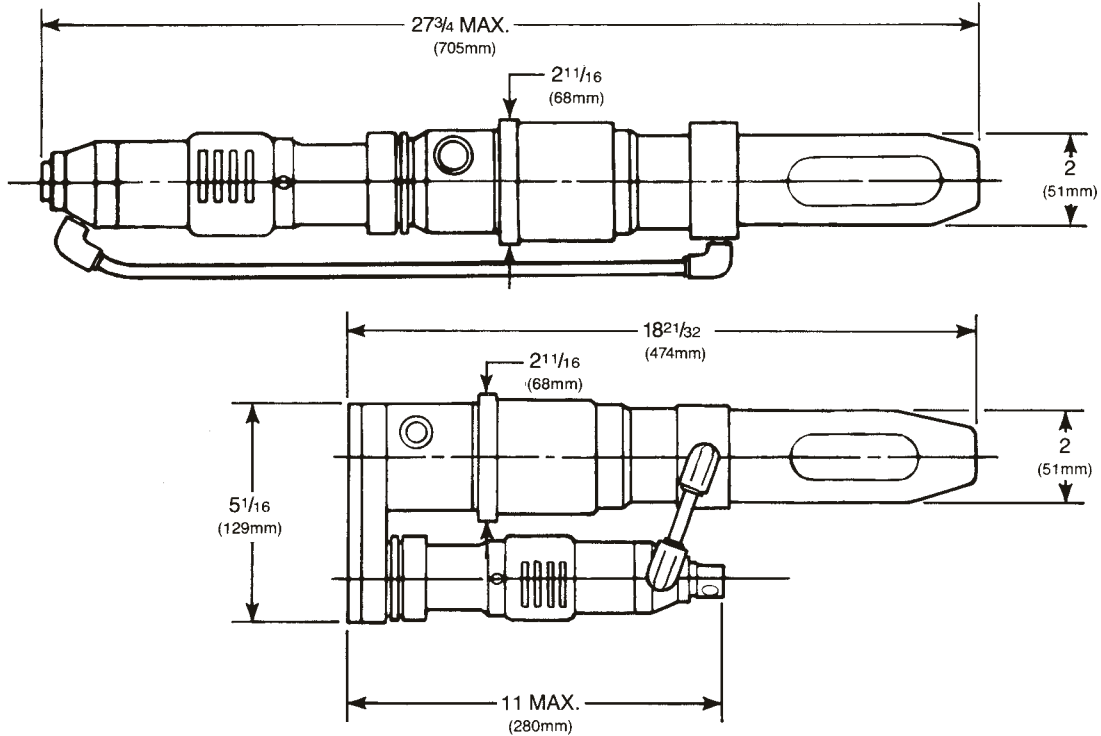

### ALUMINUM TOOL NOSE

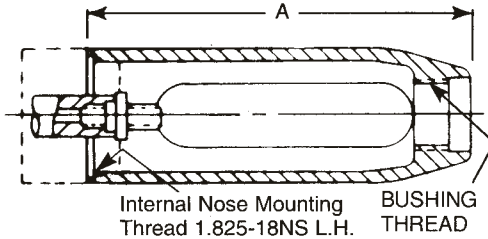

Bushing Thread	Length A	Part Number
.75 - 16LH	6.875 (175mm)	619954
1 -14LH	7.125 (181mm)	619955
1.25 - 12LH	7.125 (181mm)	619953

### 3-JAW CHUCK

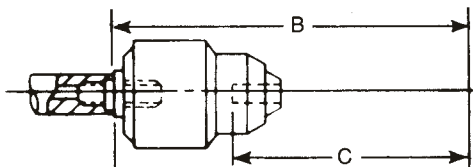

Bushing Thread	Dimension B	Dimension C	Desc.	Part Number
.75 - 16LH	6 (152mm)	4.5313 (115mm)	.375" Chuck	614929
1 -14LH	6.25 (159mm)	5.625 (144mm)	Key	849123
1.25 - 12LH	6.25 (159mm)	5.625 (144mm)		

### FLUID CHUCK

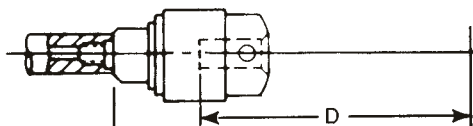

Bushing Thread	Dim. D Side Feed	Dim. D End Feed	Part Number*
.75 - 16LH	5.4688 (139mm)	4.6875 (119mm)	
1 -14LH	5.7188 (145mm)	4.9375 (125mm)	
1.25 - 12LH	5.7188 (145mm)	4.9375 (125mm)	

\*See page 1-37 for Selection and Part Number

### MORSE TAPER ADAPTER

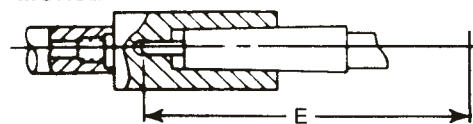

Bushing Thread	Dim. E No. 1 MT 613542	Dim. E No. 2 MT 612934
.75 - 16LH	5.4688 (138mm)	5.625 (142mm)
1 -14LH	5.7188 (145mm)	5.8438 (148mm)
1.25 - 12LH	5.7188 (145mm)	5.8438 (148mm)

## QUACKENBUSH™

### 158QGDA-S275B Semi-Automatic Series

**Capacity:**

Aluminum – .375" (9.5mm)

Titanium – .3125" (7.9mm)

Steel – .3125" (7.9mm)

**Stroke:**

Max – 2.75" (70mm)

Min. – .625" (16mm)

- 158 series motor develops 1.6 nominal horsepower.
- Available in straight and piggy-back models with fixed and variable speed motors.
- Semi-automatic operation.
- When throttle is activated, the spindle rotates and feed mechanism engages automatically.
- Upon completion of drilling cycle, the spindle returns to starting position and continues to rotate until throttle is turned off.
- Length of stroke can be adjusted forward and rear.
- Overload clutch protects feed mechanism.



158QGDAB-S275B

158QGDA-S275B

Model	Motor Configuration	Maximum Stroke		Weight		Spindle Speeds	Feed Per Revolution	Chuck Capacity	Inlet	Minimum Hose Size
		in.	mm	lbs	kg					
158QGDA-S275B	Straight	2.75"	70	13	5.89	95, 135, 165, 175, 190, 215, 245, 265, 350, 380, 420, 445, 525, 700, 750, 850, 900, 1100, 1450, 1500, 1745, 1800, 2175, 2900, 3600	.0005, .001, .002, .003, .004, .006, .008	.375"	.375" NPT	.375"
158QGAV-S275B Variable Speed	Straight	2.75"	70	13	5.89	95/245, 75, 445, 350/850, 750/1800, 1450/3600	.0005, .001, .002, .003, .004, .006, .008	.375"	.375" NPT	.375"
158QGDAB-S275B	Piggy Back	2.75"	70	15	6.8	125, 150, 185, 250, 265, 310, 320, 400, 450, 535, 540, 640, 660, 900, 1100, 1460, 1740, 2100, 2870, 3440	.0005, .001, .002, .003, .004, .006, .008	.375"	.375" NPT	.375"
158QGDABV-S275B Variable Speed	Piggy Back	2.75"	70	15	6.8	125/310, 265/640, 450/1100, 1460/3440	.0005, .001, .002, .003, .004, .006, .008	.375"	.375" NPT	.375"

**STANDARD EQUIPMENT:**  
3 Jaw Chuck 849103-7 and Key 849123-5.

**NOTE:**  
Specify TOOL NOSE when ordering. Standard Noses page 1-15.  
Rated tool performance at 90 PSIG measured at tool inlet with motor running.  
When selecting speeds and feeds, see page I-5.  
SEE PAGES I-11-I-13 FOR SAFETY PRECAUTIONS.

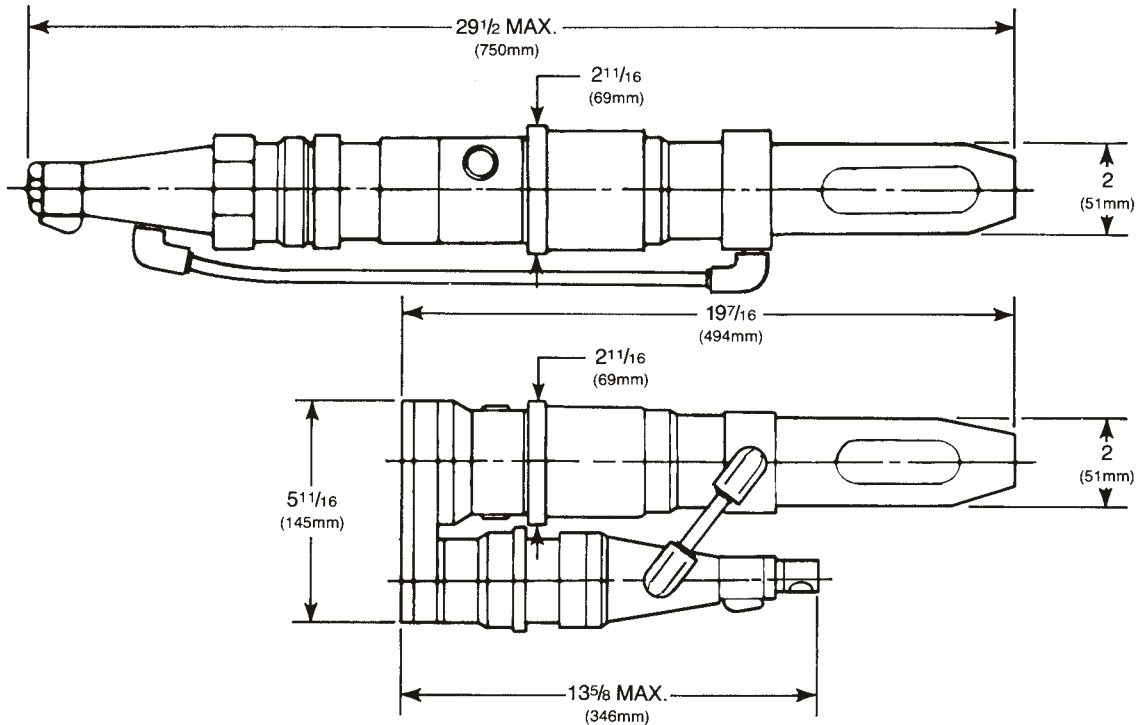

### ALUMINUM TOOL NOSE

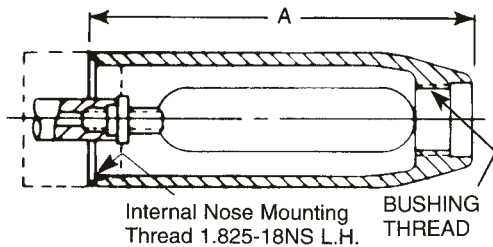

Bushing Thread	Length A	Part Number
.75 - 16LH	6.875 (175mm)	619954
1 - 14LH	7.125 (181mm)	619955
1.25 - 12LH	7.125 (181mm)	619953

### 3-JAW CHUCK

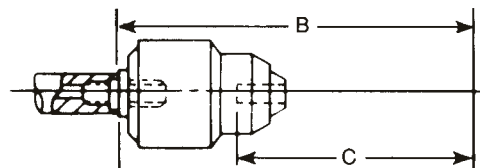

Bushing Thread	Dimension B	Dimension C	Desc.	Part Number
.75 - 16LH	6 (152mm)	4.5313 (115mm)	.375" Chuck	614929
1 - 14LH	6.25 (159mm)	5.625 (144mm)	Key	849123
1.25 - 12LH	6.25 (159mm)	5.625 (144mm)		

### FLUID CHUCK

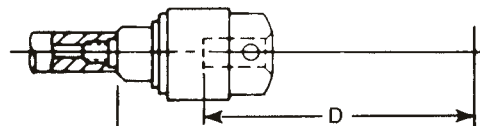

Bushing Thread	Dim. D Side Feed	Dim. D End Feed	Part Number*
.75 - 16LH	5.4688 (139mm)	4.6875 (119mm)	
1 - 14LH	5.7188 (145mm)	4.9375 (125mm)	
1.25 - 12LH	5.7188 (145mm)	4.9375 (125mm)	

### MORSE TAPER ADAPTER

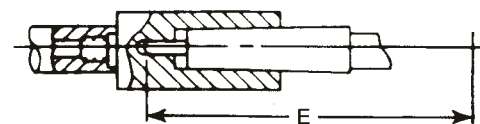

Bushing Thread	Dim. E No. 1 MT 613542	Dim. E No. 2 MT 612934
.75 - 16LH	5.4688 (138mm)	5.625 (142mm)
1 - 14LH	5.7188 (145mm)	5.8438 (148mm)
1.25 - 12LH	5.7188 (145mm)	5.8438 (148mm)

\*See page 1-37 for Selection and Part Number

## QUACKENBUSH™

### 158QGDB-S400 Series

**Capacity:**

Aluminum – 1.25" (32mm)

Titanium – 1" (25.4mm)

Steel – 1" (25.4mm)

**Stroke:**

Max – 4" (101mm)

Min. – 1 .75" (44mm)

- 158 series motor develops 1.6 nominal horsepower.
- Piggy-back motor mount reduces overhang.
- Length of stroke can be adjusted by rotating both the forward and rear stroke adjustment collars.
- Drill feed is activated by rotating feed engagement collar.
- Spindle may be returned to starting position at any time during feed cycle.
- At end of stroke, spindle automatically returns to starting position.
- Available in single governed speeds and variable speed ranges.
- Overload clutch protects feed mechanism.



158QGDBV-S400

Model	Motor Configuration	Maximum Stroke		Weight		Spindle Speeds	Feed Per Revolution	Chuck Capacity	Inlet	Minimum Hose Size
		in.	mm	lbs	kg					
158QGDB-S400	Piggy Back	4"	102	18.5	8.39	55, 80, 95, 110, 125, 135, 150, 185, 250, 310, 400, 535, 660, 900, 1100, 2100, 2870, 3440	.0005, .001, .002, .003, .004, .006, .008, .012, 016	.5"	.375" NPT	.5"
158QGDBV-S400 Variable Speed	Piggy Back	4"	102	18.5	8.39	55-135, 125-310, 265-640, 450-1100, 450-1100, 1460-3440	.0005, .001, .002, .003, .004, .006, .008, .012, 016	.5"	.375" NPT	.5"

**STANDARD EQUIPMENT:**  
3 Jaw Chuck 849415 and Key 849121.

**NOTE:**  
Specify TOOL NOSE when ordering. Standard Noses page 1-17.  
Rated tool performance at 90 PSIG measured at tool inlet with motor running.  
When selecting speeds and feeds, see page I-5.  
SEE PAGES I-11-I-13 FOR SAFETY PRECAUTIONS.



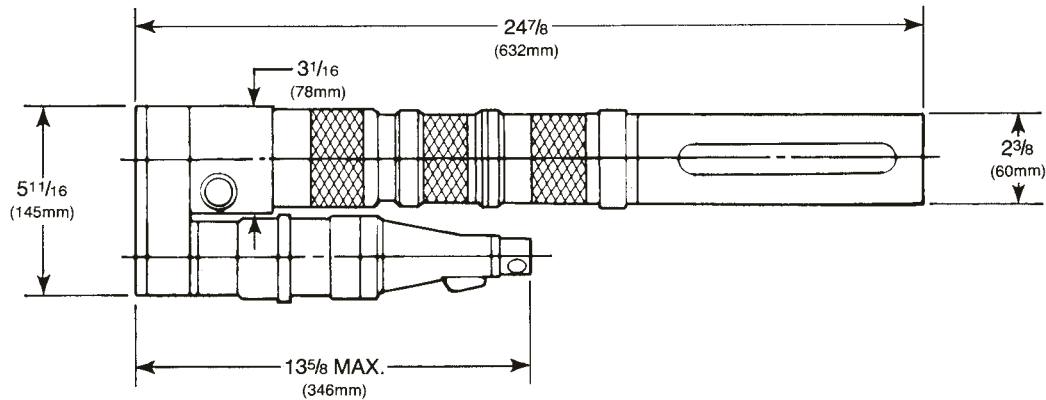

## STEEL TOOL NOSE

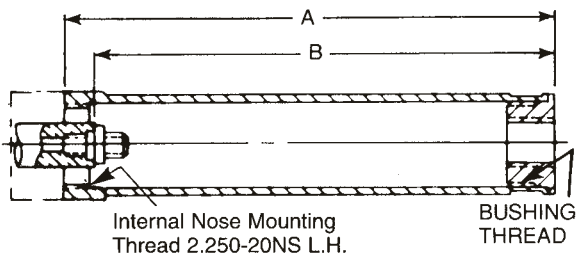

Bushing Thread	Length A	Length B	Part Number
.75 - 16LH	9.5 (241mm)	8.75 (227mm)	621235
1 - 14LH	9.5 (241mm)	8.75 (227mm)	621236
1.25 - 12LH	9.5 (241mm)	8.75 (227mm)	621237
1.5 - 12LH	9.5 (241mm)	8.75 (227mm)	621238
2 - 16LH	9.375 (238mm)	8.625 (223mm)	614751

## 3-JAW CHUCK

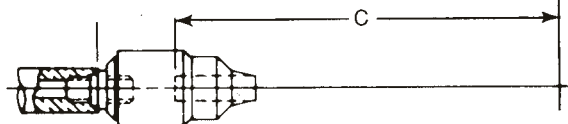

Bushing Thread	Dimension C	Desc.	Part Number
.75 - 16LH	7.2813 (185mm)	.5" Chuck	849415
1 - 14LH	7.2813 (185mm)	Key	849121
1.25 - 12LH	7.2813 (185mm)		
1.5 - 12LH	7.2813 (185mm)		
2 - 16LH	7.2188 (182mm)		

## FLUID CHUCK

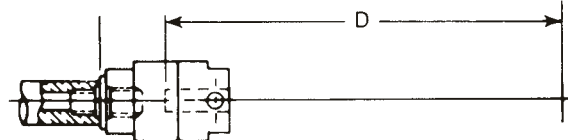

Bushing Thread	Dim. D Side Feed	Dim. D End Feed	Part Number*
.75 - 16LH	7.75 (199mm)	7.4375 (189mm)	
1 - 14LH	7.75 (199mm)	7.4375 (189mm)	
1.25 - 12LH	7.75 (199mm)	7.4375 (189mm)	
1.5 - 12LH	7.75 (199mm)	7.4375 (189mm)	
2 - 16LH	7.75 (199mm)	7.3125 (185mm)	

\*See page 1-37 for Selection and Part Number

## MORSE TAPER ADAPTER

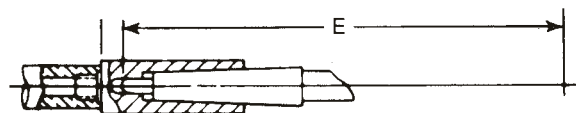

Bushing Thread	Dim. E No. 1 MT 619533	Dim. E No. 2 MT 619405	Dim. E No. 3 MT 619406	Dim. E No. 4 MT 623931
.75 - 16LH	8.0625 (205mm)	8.0625 (205mm)	8.1875 (208mm)	7.9375 (202mm)
1 - 14LH	8.0625 (205mm)	8.0625 (205mm)	8.1875 (208mm)	7.9375 (202mm)
1.25 - 12LH	8.0625 (205mm)	8.0625 (205mm)	8.1875 (208mm)	7.9375 (202mm)
1.5 - 12LH	8.0625 (205mm)	8.0625 (205mm)	8.1875 (208mm)	7.9375 (202mm)
2 - 16LH	8.9375 (227mm)	8.9375 (227mm)	8.0625 (205mm)	7.75 (198mm)

## QUACKENBUSH™

### 158QGDB-RF-S400 Back Spotfacer Series

**Stroke:**

Max – 4” (101mm)  
Min. – 1.75” (44mm)

- 158 series motor develops 1.6 nominal horsepower.
- Piggy-back motor mount reduces overhang.
- Length of stroke can be adjusted by rotating both the forward and rear stroke adjustment collars.
- Reverse feed is activated by rotating feed engagement collar.
- Spindle may be returned to starting position at any time during feed cycle by manually rotating feed engagement collar
- At end of stroke, spindle automatically returns to starting position.
- Available in single governed speeds and variable speed ranges.
- Overload clutch protects feed mechanism.



158QGDBV-RF-S400

Model	Motor Configuration	Maximum Stroke		Weight		Spindle Speeds	Feed Per Revolution	Chuck Capacity	Inlet	Minimum Hose Size
		in.	mm	lbs	kg					
158QGDB-RF-S400	Piggy Back	4"	102	18.5	8.39	55, 80, 95, 110, 125, 135, 150, 185, 250, 310, 400, 535, 660, 900, 1100, 2100, 2870, 3440	.0005, .001, .002, .003, .004, .006, .008, .012, 016	.5"	.375" NPT	.5"
158QGDBV-RF-S400 Variable Speed	Piggy Back	4"	102	18.5	8.39	55-135, 125-310, 265-640, 450-1100, 450-1100, 1460-3440	.0005, .001, .002, .003, .004, .006, .008, .012, 016	.5"	.375" NPT	.5"

**STANDARD EQUIPMENT:**  
3 Jaw Chuck 849415 and Key 849121.

**NOTE:**  
Specify TOOL NOSE when ordering. Standard Noses page 1-19.  
Rated tool performance at 90 PSIG measured at tool inlet with motor running.  
When selecting speeds and feeds, see page I-5.  
SEE PAGES I-11-I-13 FOR SAFETY PRECAUTIONS.

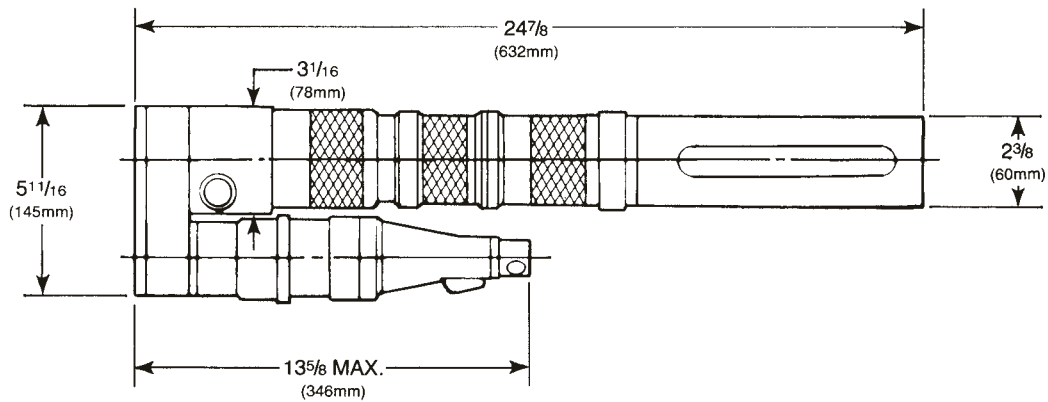

## STEEL TOOL NOSE

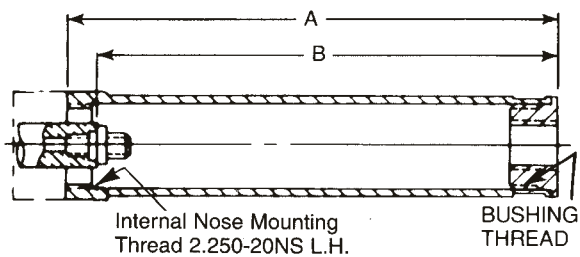

Bushing Thread	Length A	Length B	Part Number
.75 - 16LH	9.5 (241mm)	8.75 (227mm)	621235
1 - 14LH	9.5 (241mm)	8.75 (227mm)	621236
1.25 - 12LH	9.5 (241mm)	8.75 (227mm)	621237
1.5 - 12LH	9.5 (241mm)	8.75 (227mm)	621238
2 - 16LH	9.375 (238mm)	8.625 (223mm)	614751

## 3-JAW CHUCK

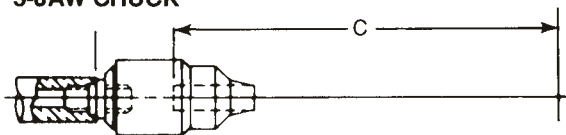

Bushing Thread	Dimension C	Desc.	Part Number
.75 - 16LH	3.2813 (83mm)	.5" Chuck	849415
1 - 14LH	3.2813 (83mm)	Key	849121
1.25 - 12LH	3.2813 (83mm)		
1.5 - 12LH	3.2813 (83mm)		
2 - 16LH	3.3438 (85mm)		

## QUACKENBUSH™

### 400QGDBV-S400 Series

**Capacity:**

- Aluminum – 1.25" (32mm)
- Titanium – 1" (25.4mm)
- Steel – 1" (25.4mm)

**Stroke:**

- Max – 4" (101mm)
- Min. – 1.75" (44mm)

- 400 series motor develops 4.0 nominal horsepower.
- Dial selectable speeds include tamper-resistant speed adjustment lock.
- Drill feed is activated by rotating feed engagement collar.
- Spindle may be returned to starting position at any time during feed cycle.
- Spindle automatically returns to starting position at end of feed stroke.
- Length of stroke can be adjusted by rotating both the forward and rear stroke adjustment collars.
- Swivel air inlet permits easy air hose repositioning.
- Motor has quick response variable speed governor.
- Overload clutch protects feed mechanism.



400QGDBV-S400

Model	Motor Configuration	Maximum Stroke		Weight		Spindle Speeds	Feed Per Revolution	Chuck Capacity	Inlet	Minimum Hose Size
		in.	mm	lbs	kg					
400QGDBV-S400	Piggy Back	4"	102	32.5	14.8	55/125, 135/310 325/750,	.0005, .001, .002, .003, .004, .006, .008, .012, 016	.5"	.5" NPT	.75"

**STANDARD EQUIPMENT:**  
3 Jaw Chuck 849415 and Key 849121.

**NOTE:**  
Specify TOOL NOSE when ordering. Standard Noses page 1-21.  
Rated tool performance at 90 PSIG measured at tool inlet with motor running.  
When selecting speeds and feeds, see page I-5.  
SEE PAGES I-11-I-13 FOR SAFETY PRECAUTIONS.

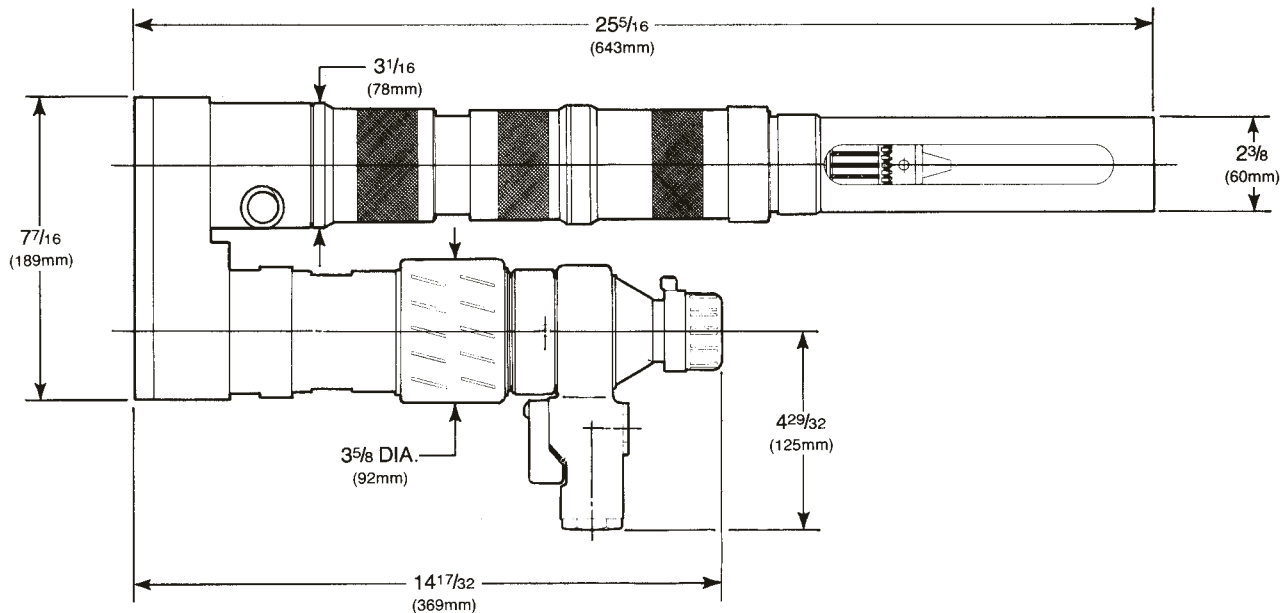

## STEEL TOOL NOSE

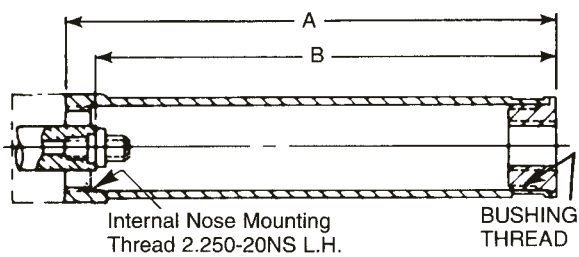

Bushing Thread	Length A	Length B	Part Number
.75 - 16LH	9.5 (241mm)	8.75 (227mm)	621235
1 - 14LH	9.5 (241mm)	8.75 (227mm)	621236
1.25 - 12LH	9.5 (241mm)	8.75 (227mm)	621237
1.5 - 12LH	9.5 (241mm)	8.75 (227mm)	621238
2 - 16LH	9.375 (238mm)	8.625 (223mm)	614751

## 3-JAW CHUCK

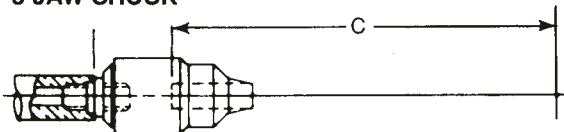

Bushing Thread	Dimension C	Desc.	Part Number
.75 - 16LH	7.2813 (185mm)	.5" Chuck	849415
1 - 14LH	7.2813 (185mm)	Key	849121
1.25 - 12LH	7.2813 (185mm)		
1.5 - 12LH	7.2813 (185mm)		
2 - 16LH	7.2188 (182mm)		

## FLUID CHUCK

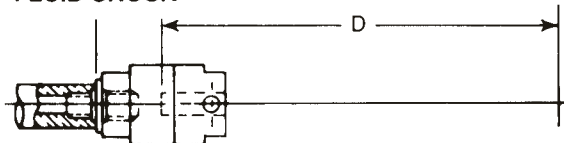

Bushing Thread	Dim. D Side Feed	Dim. D End Feed	Part Number*
.75 - 16LH	7.75 (199mm)	7.4375 (189mm)	
1 - 14LH	7.75 (199mm)	7.4375 (189mm)	
1.25 - 12LH	7.75 (199mm)	7.4375 (189mm)	
1.5 - 12LH	7.75 (199mm)	7.4375 (189mm)	
2 - 16LH	7.75 (199mm)	7.3125 (185mm)	

\*See page 1-37 for Selection and Part Number

## MORSE TAPER ADAPTER

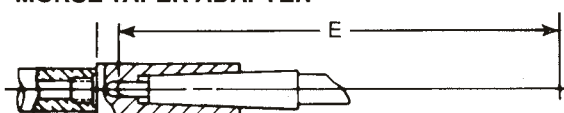

Bushing Thread	Dim. E No. 1 MT 619533	Dim. E No. 2 MT 619405	Dim. E No. 3 MT 619406	Dim. E No. 4 MT 623931
.75 - 16LH	8.0625 (205mm)	8.0625 (205mm)	8.1875 (208mm)	7.9375 (202mm)
1 - 14LH	8.0625 (205mm)	8.0625 (205mm)	8.1875 (208mm)	7.9375 (202mm)
1.25 - 12LH	8.0625 (205mm)	8.0625 (205mm)	8.1875 (208mm)	7.9375 (202mm)
1.5 - 12LH	8.0625 (205mm)	8.0625 (205mm)	8.1875 (208mm)	7.9375 (202mm)
2 - 16LH	8.9375 (227mm)	8.9375 (227mm)	8.0625 (205mm)	7.75 (198mm)

## QUACKENBUSH™

### 400QGDBV-RF-S400 Back Spotfacer Series

**Stroke:**

Max – 4" (101mm)  
Min. – 1.75" (44mm)

- 400 series motor develops 4.0 nominal horsepower.
- Dial selectable speeds include tamper-resistant speed adjustment lock.
- Reverse feed is activated by rotating feed engagement collar.
- Spindle may be returned to starting position at any time during feed cycle.
- Spindle automatically returns to starting position at end of feed stroke.
- Length of stroke can be adjusted by rotating both the forward and rear stroke adjustment collars.
- Swivel air inlet permits easy air hose repositioning.
- Motor has quick response variable speed governor.
- Overload clutch protects feed mechanism.



400QGDBV-RF-S400

Model	Motor Configuration	Maximum Stroke		Weight		Spindle Speeds	Feed Per Revolution	Chuck Capacity	Inlet	Minimum Hose Size
		in.	mm	lbs	kg					
400QGDBV-RF-S400	Piggy Back	4"	102	32.5	14.8	55/125, 135/310 325/750	.0005, .001, .002, .003, .004, .006, .008, .012, 016	.5"	.5" NPT	.75"

**STANDARD EQUIPMENT:**  
3 Jaw Chuck 849415 and Key 849121.

**NOTE:**  
Specify TOOL NOSE when ordering. Standard Noses page 1-23.  
Rated tool performance at 90 PSIG measured at tool inlet with motor running.  
When selecting speeds and feeds, see page I-5.  
SEE PAGES I-11-I-13 FOR SAFETY PRECAUTIONS.

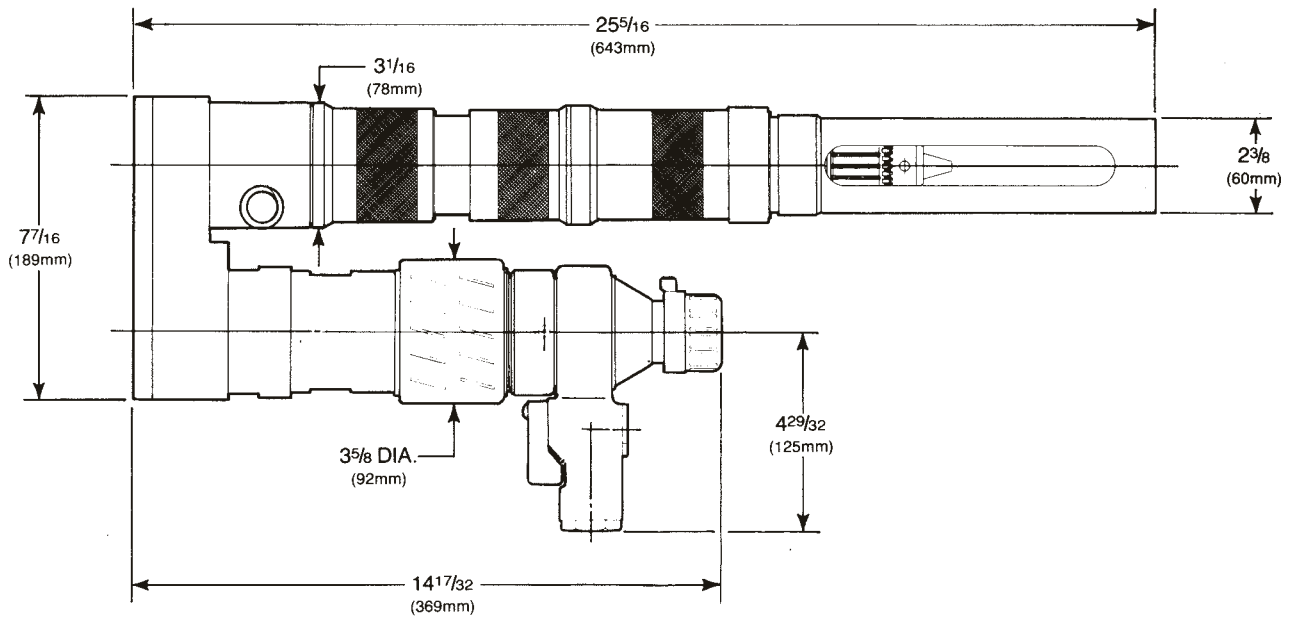

## STEEL TOOL NOSE

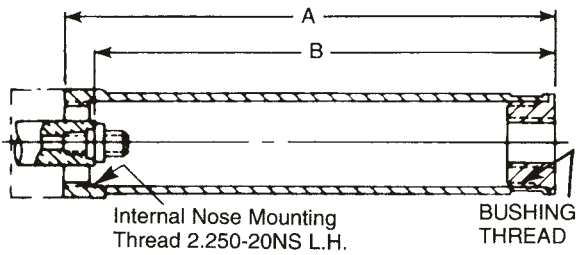

Bushing Thread	Length A	Length B	Part Number
.75 - 16LH	9.5 (241mm)	8.75 (227mm)	621235
1 - 14LH	9.5 (241mm)	8.75 (227mm)	621236
1.25 - 12LH	9.5 (241mm)	8.75 (227mm)	621237
1.5 - 12LH	9.5 (241mm)	8.75 (227mm)	621238
2 - 16LH	9.375 (238mm)	8.625 (223mm)	614751

## 3-JAW CHUCK

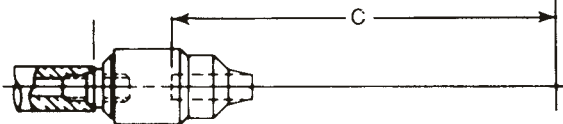

Bushing Thread	Dimension C	Desc.	Part Number
.75 - 16LH	3.2813 (83mm)	.5" Chuck	849415
1 - 14LH	3.2813 (83mm)	Key	849121
1.25 - 12LH	3.2813 (83mm)		
1.5 - 12LH	3.2813 (83mm)		
2 - 16LH	3.6875 (85mm)		

## QUACKENBUSH™

### 158QGDB-S600 Series

**Capacity:**

Aluminum – 1.25" (32mm)

Titanium – 1" (25.4mm)

Steel – 1" (25.4mm)

**Stroke:**

Max – 6" (152mm)

Min. – 1.75" (44mm)

- 158 series motor develops 1.6 nominal horsepower.
- Piggy-back motor mount reduces overhang.
- Length of stroke can be adjusted by rotating both forward and rear stroke adjustment collars.
- Drill feed is activated by rotating feed engagement collar.
- Spindle may be returned to starting position at any time during feed cycle by manually rotating feed engagement collar.
- At end of stroke, spindle automatically returns to starting position.
- Available in single governed speeds and variable speed ranges.
- Overload clutch protects feed mechanism.



158QGDB-S600

Model	Motor Configuration	Maximum Stroke		Weight		Spindle Speeds	Feed Per Revolution	Chuck Capacity	Inlet	Minimum Hose Size
		in.	mm	lbs	kg					
158QGDB-S600	Piggy Back	6"	152.4	25	11.34	55, 80, 95, 110, 125, 135, 150, 185, 250, 310, 400, 535, 660, 900, 1100, 2100, 2870, 3440	.0005, .001, .002, .003, .004, .006, .008, .012, 016	.5"	.375" NPT	.5"
158QGDBV-S600 Variable Speed	Piggy Back	6"	152.4	25	11.34	55-135, 125-310, 265-640, 450-1100, 450-1100, 1460-3440	.0005, .001, .002, .003, .004, .006, .008, .012, 016	.5"	.375" NPT	.5"

**STANDARD EQUIPMENT:**  
3 Jaw Chuck 849415 and Key 849121.

**NOTE:**  
Specify TOOL NOSE when ordering. Standard Noses page 1-25.  
Rated tool performance at 90 PSIG measured at tool inlet with motor running.  
When selecting speeds and feeds, see page I-5.  
SEE PAGES I-11-I-13 FOR SAFETY PRECAUTIONS.



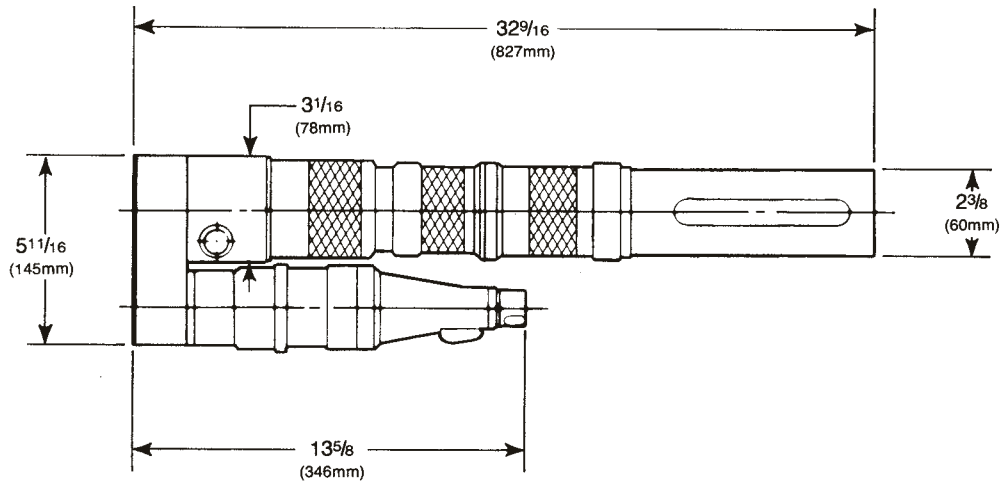

## STEEL TOOL NOSE

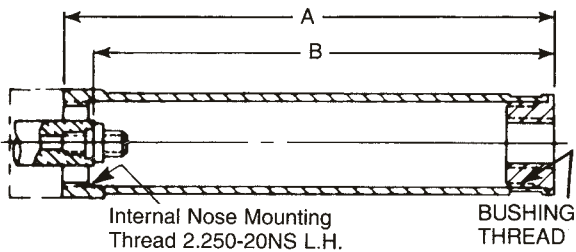

Bushing Thread	Length A	Length B	Part Number
1 - 14LH	11.5 (292mm)	10.75 (273mm)	621244
1.25 - 12LH	11.5 (292mm)	10.75 (273mm)	621245
1.5 - 12LH	11.5 (292mm)	10.75 (273mm)	621246
2 - 16LH	11.375 (289mm)	10.625 (270mm)	614757

## 3-JAW CHUCK

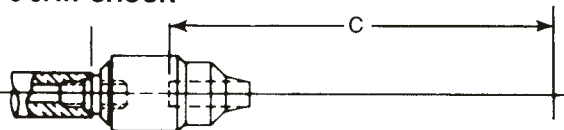

Bushing Thread	Dimension C	Desc.	Part Number
1 - 14LH	9.2813 (235mm)	.5" Chuck	849415
1.25 - 12LH	9.2813 (235mm)	Key	849121
1.5 - 12LH	9.2813 (235mm)		
2 - 16LH	9.1563 (232mm)		

## FLUID CHUCK

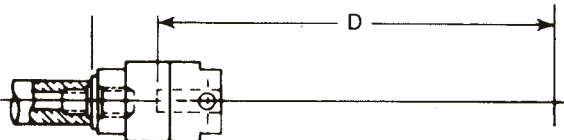

Bushing Thread	Dim. D Side Feed	Dim. D End Feed	Part Number*
1 - 14LH	9.875 (250mm)	9.4375 (239mm)	
1.25 - 12LH	9.875 (250mm)	9.4375 (239mm)	
1.5 - 12LH	9.875 (250mm)	9.4375 (239mm)	
2 - 16LH	9.75 (247mm)	9.3125 (236mm)	

\*See page 1-37 for Selection and Part Number

## MORSE TAPER ADAPTER

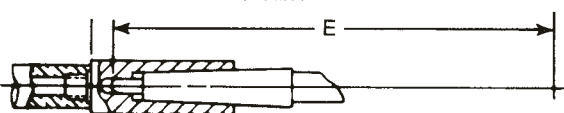

Bushing Thread	Dim. E No. 1 MT 619533	Dim. E No. 2 MT 619405	Dim. E No. 3 MT 619406	Dim. E No. 4 MT 623931
1 - 14LH	10.0625 (255mm)	10.0625 (255mm)	10.1875 (258mm)	9.875 (252mm)
1.25 - 12LH	10.0625 (255mm)	10.0625 (255mm)	10.1875 (258mm)	9.875 (252mm)
1.5 - 12LH	10.0625 (255mm)	10.0625 (255mm)	10.1875 (258mm)	9.875 (252mm)
2 - 16LH	9.875 (252mm)	9.875 (252mm)	10.0625 (255mm)	9.8125 (249mm)

## QUACKENBUSH™

### 400QGDBV-S600 Series

**Capacity:**

- Aluminum – 1.25" (32mm)
- Titanium – 1" (25.4mm)
- Steel – 1" (25.4mm)

**Stroke:**

- Max – 6" (152mm)
- Min. – 1.75" (44mm)

- 400 series motor develops 4.0 nominal horsepower.
- Dial selectable speeds include tamper-resistant speed adjustment lock.
- Feed is activated by rotating feed engagement collar.
- Spindle may be returned to starting position at any time during feed cycle.
- Spindle automatically returns to starting position at end of feed stroke.
- Length of stroke can be adjusted by rotating both the forward and rear stroke adjustment collars.
- Swivel air inlet permits easy air hose repositioning.
- Motor has quick response variable speed governor.
- Overload clutch protects feed mechanism.



400QGDBV-S600

Model	Motor Configuration	Maximum Stroke		Weight		Spindle Speeds	Feed Per Revolution	Chuck Capacity	Inlet	Minimum Hose Size
		in.	mm	lbs	kg					
400QGDBV-S600	Piggy Back	6"	152.4	39	17.7	55-125, 135-310, 325-750	.0005, .001, .002, .003, .004, .006, .008, .012, 016	.5"	.5" NPT	.75"

**STANDARD EQUIPMENT:**  
3 Jaw Chuck 849415 and Key 849121.

**NOTE:**  
Specify TOOL NOSE when ordering. Standard Noses page 1-27.  
Rated tool performance at 90 PSIG measured at tool inlet with motor running.  
When selecting speeds and feeds, see page I-5.  
SEE PAGES I-11-I-13 FOR SAFETY PRECAUTIONS.

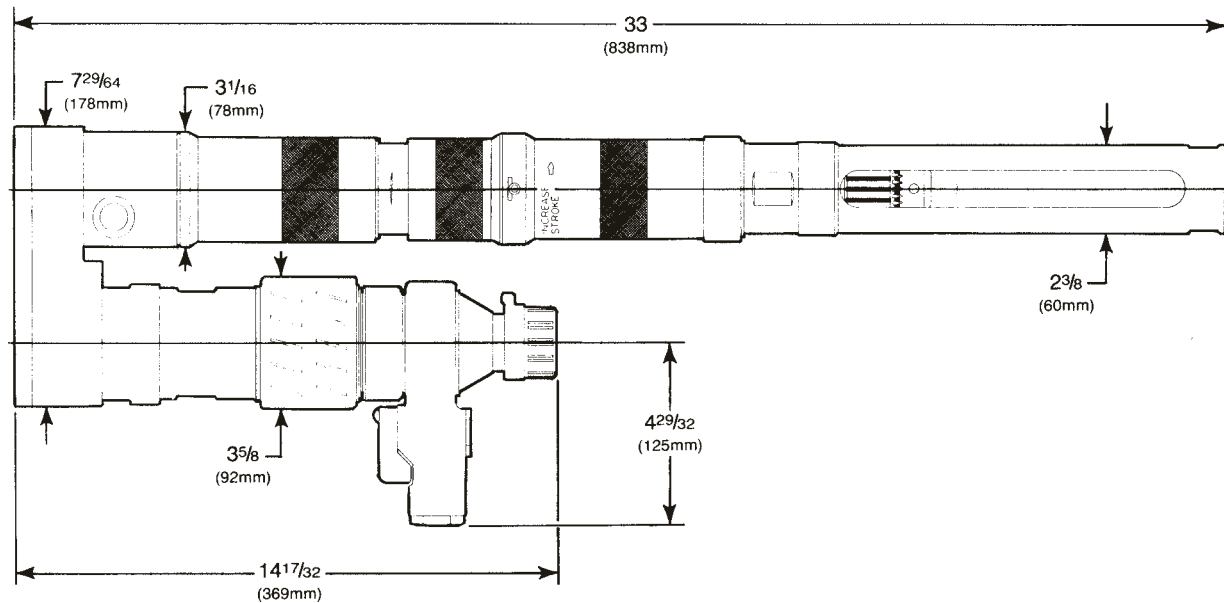

## STEEL TOOL NOSE

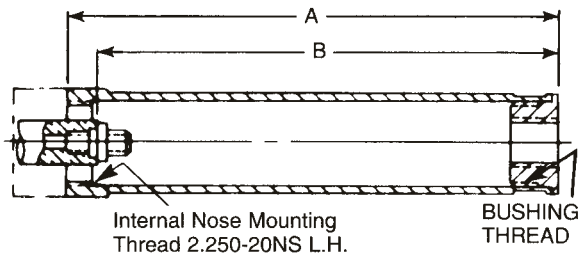

Bushing Thread	Length A	Length B	Part Number
1 - 14LH	11.5 (292mm)	10.75 (273mm)	621244
1.25 - 12LH	11.5 (292mm)	10.75 (273mm)	621245
1.5 - 12LH	11.5 (292mm)	10.75 (273mm)	621246
2 - 16LH	11.375 (289mm)	10.625 (270mm)	614757

## 3-JAW CHUCK

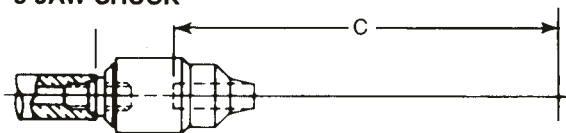

Bushing Thread	Dimension C	Desc.	Part Number
1 - 14LH	9.2813 (235mm)	.5" Chuck	849415
1.25 - 12LH	9.2813 (235mm)	Key	849121
1.5 - 12LH	9.2813 (235mm)		
2 - 16LH	9.1563 (232mm)		

## FLUID CHUCK

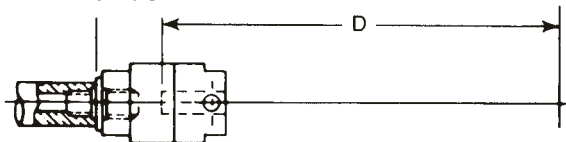

Bushing Thread	Dim. D Side Feed	Dim. D End Feed	Part Number*
1 - 14LH	9.875 (250mm)	9.4375 (239mm)	
1.25 - 12LH	9.875 (250mm)	9.4375 (239mm)	
1.5 - 12LH	9.875 (250mm)	9.4375 (239mm)	
2 - 16LH	9.75 (247mm)	9.3125 (236mm)	

\*See page 1-37 for Selection and Part Number

## MORSE TAPER ADAPTER

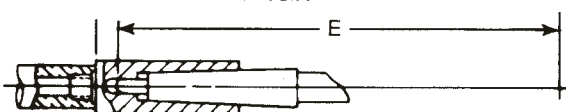

Bushing Thread	Dim. E No. 1 MT 619533	Dim. E No. 2 MT 619405	Dim. E No. 3 MT 619406	Dim. E No. 4 MT 623931
1 - 14LH	10.0625 (255mm)	10.0625 (255mm)	10.1875 (258mm)	9.875 (252mm)
1.25 - 12LH	10.0625 (255mm)	10.0625 (255mm)	10.1875 (258mm)	9.875 (252mm)
1.5 - 12LH	10.0625 (255mm)	10.0625 (255mm)	10.1875 (258mm)	9.875 (252mm)
2 - 16LH	9.875 (252mm)	9.875 (252mm)	10.0625 (255mm)	9.8125 (249mm)

## QUACKENBUSH™

### 400QGDABV-S700 Series

**Capacity:**

- Aluminum – 2.5" (63.5mm)
- Titanium – 1.5" (38.1mm)
- Steel – 1.5" (38.1mm)

**Stroke:**

- Max – 7" (178mm)
- Min. – 2.9375" (75mm)

- 400 series motor develops 4.0 nominal horsepower.
- Dial selectable speeds include tamper-resistant speed adjustment lock.
- Swivel inlet permits easy air hose repositioning.
- Length of forward stroke can be changed by adjusting the forward stop mechanism located under cover sleeve. Rear stroke is adjusted by use of rear stroke adjustment wrench.
- Feed mechanism is engaged by sliding conveniently located feed engagement valve.
- Motor has quick response variable speed governor.
- Overload clutch protects feed mechanism.



400QGDABV-S700

Model	Motor Configuration	Maximum Stroke		Wt. w/nosepiece		Wt. wo/nosepiece		Spindle Speeds	Feed Per Revolution	Inlet	Minimum Hose Size
		in.	mm	lbs	kg	lbs	kg				
400QGDABV-S700	Piggy Back	7"	178	51.5	23.36	45.75	20.75	55-125, 135-310, 325-750	.0005, .001, .002, .003, .004, .006, .008, .012, 016	.5" NPT	.75"

**STANDARD EQUIPMENT:**  
Rear Stroke Adjustment Wrench 614189.

**NOTE:**  
Specify TOOL NOSE when ordering. Standard Noses page 1-29.  
Rated tool performance at 90 PSIG measured at tool inlet with motor running.  
When selecting speeds and feeds, see page I-5.  
SEE PAGES I-11-I-13 FOR SAFETY PRECAUTIONS.

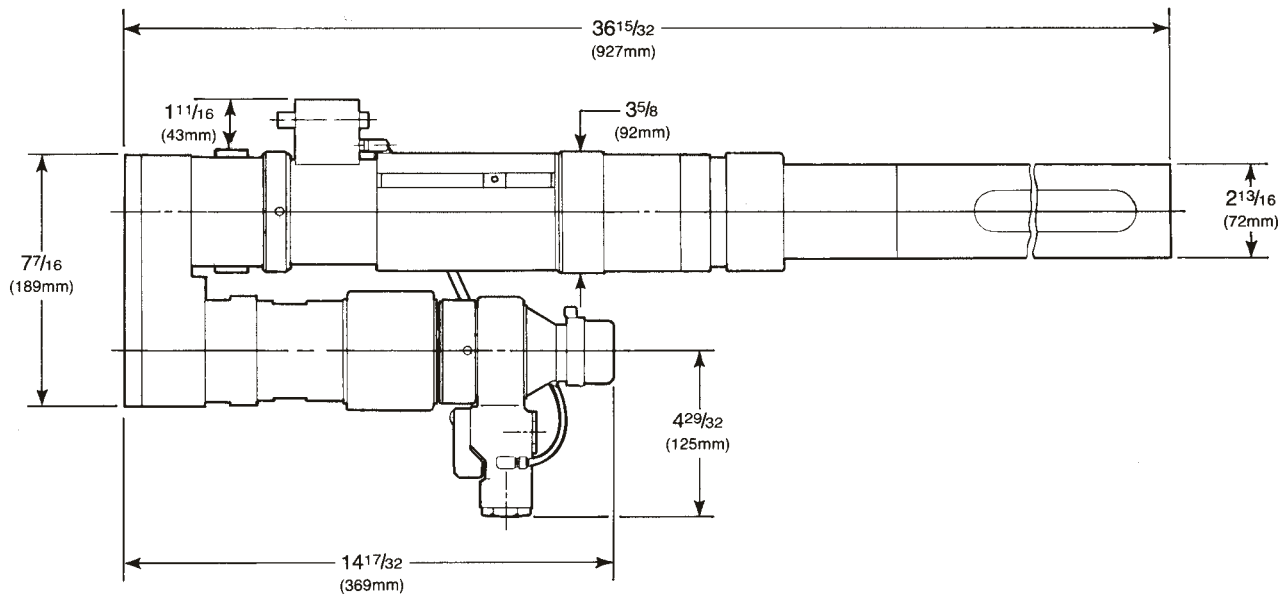

## STEEL TOOL NOSE

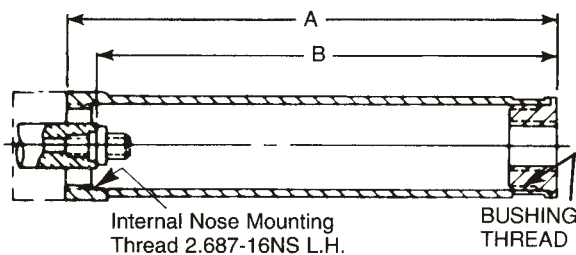

Bushing Thread	Length A	Length B	Part Number
1 - 14LH	13.5625 (345mm)	12.75 (324mm)	621228
1.25 - 12LH	13.5625 (345mm)	12.75 (324mm)	621229
1.5 - 12LH	13.5625 (345mm)	12.75 (324mm)	621230
2 - 16LH	13.4375 (341mm)	12.625 (321mm)	614749

## FLUID CHUCK

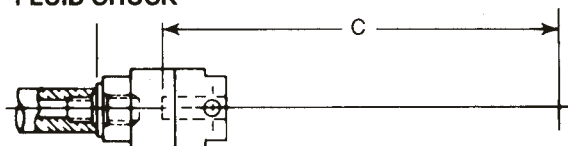

Bushing Thread	Dim. D Side Feed	Dim. D End Feed	Part Number*
1 - 14LH	11.875 (301mm)	11.25 (286mm)	
1.25 - 12LH	11.875 (301mm)	11.25 (286mm)	
1.5 - 12LH	11.875 (301mm)	11.25 (286mm)	
2 - 16LH	11.75 (298mm)	11.1563 (283mm)	

\*See page 1-37 for Selection and Part Number

## MORSE TAPER ADAPTER

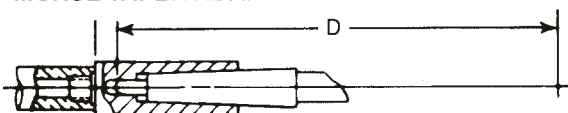

Bushing Thread	Dim. E No. 2 MT 619832	Dim. E No. 3 MT 619819	Dim. E No. 4 MT 619820
1 - 14LH	12 (305mm)	11.875 (301mm)	11.9375 (303mm)
1.25 - 12LH	12 (305mm)	11.875 (301mm)	11.9375 (303mm)
1.5 - 12LH	12 (305mm)	11.875 (301mm)	11.9375 (303mm)
2 - 16LH	11.875 (301mm)	11.8125 (299mm)	11.8125 (299mm)

## QUACKENBUSH™

### 400QGDBV-S750 Series

**Capacity:**

Aluminum – 2 .5” (63.5mm)

Titanium – 1.5” (38.1mm)

Steel – 1.5” (38.1mm)

**Stroke:**

Max – 7.5” (190mm)

Min. – .0625” (2mm)

- 400 series motor develops 4.0 nominal horsepower.
- Hand wheel on rear of tool has two-position gear case with manual feed rates of approximately .010 in. and .125 in. per handle revolution.
- Spindle is advanced to the workpiece using the hand wheel and the automatic feed is manually engaged for drilling.
- Hand wheel feature enables tool to be used for forward and back spot facing, line boring, reaming as well as rapid manual advance of cutter to workpiece.
- Drilling cycle is activated by sliding feed collar toward hand crank and rotating feed engagement collar.
- At end of drilling cycle spindle is retracted by pulling the hand crank out and turning it counter clockwise. Spindle is returned to starting position by rotating hand wheel.
- Dial selectable speeds include tamper-resistant speed adjustment lock.
- Automatic overload clutch protects feed mechanism.
- Swivel inlet permits easy air hose repositioning.
- Motor has quick response variable speed governor.



400QGDBAV-S750

Model	Motor Configuration	Maximum Stroke		Wt. w/nosepiece		Wt. wo/nosepiece		Spindle Speeds	Feed Per Revolution	Inlet	Minimum Hose Size
		in.	mm	lbs	kg	lbs	kg				
400QGDBV-S750	Piggy Back	7.5"	190	63.5	28.8	57.75	26.2	55-125, 135-310, 325-750	.0005, .001, .002, .003, .004, .006, .008, .012, 016	.5" NPT	.75"

**STANDARD EQUIPMENT:**

Standard noses page 1-31 specify when ordering.

**NOTE:**

Rated tool performance at 90 PSIG measured at tool inlet with motor running. When selecting speeds and feeds, see page I-5. SEE PAGES I-11-I-13 FOR SAFETY PRECAUTIONS.

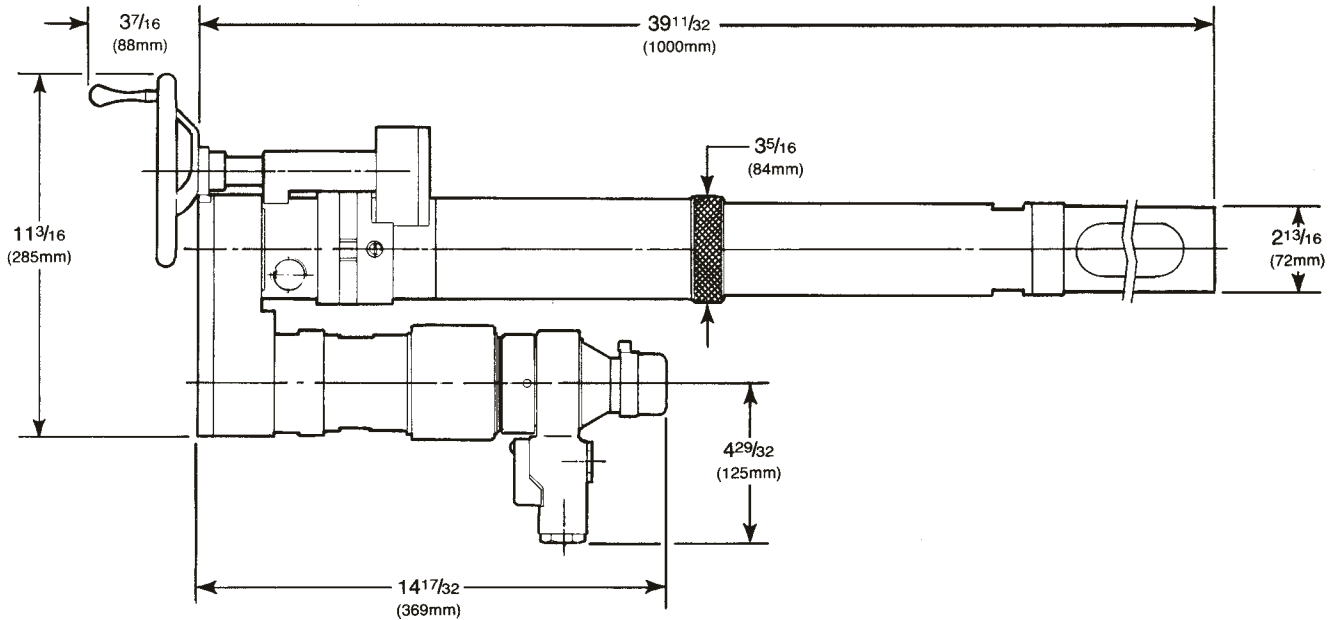

## STEEL TOOL NOSE

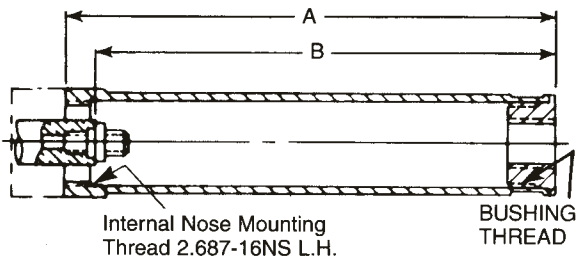

Bushing Thread	Length A	Length B	Part Number
1 - 14LH	13.5625 (345mm)	12.75 (324mm)	621228
1.25 - 12LH	13.5625 (345mm)	12.75 (324mm)	621229
1.5 - 12LH	13.5625 (345mm)	12.75 (324mm)	621230
2 - 16LH	13.4375 (341mm)	12.625 (321mm)	614749

## FLUID CHUCK

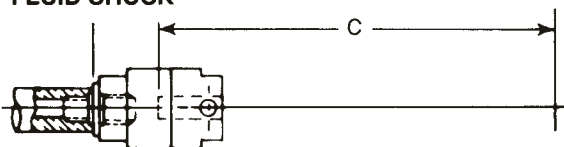

Bushing Thread	Dim. D Side Feed	Dim. D End Feed	Part Number*
1 - 14LH	11.875 (301mm)	11.25 (286mm)	
1.25 - 12LH	11.875 (301mm)	11.25 (286mm)	
1.5 - 12LH	11.875 (301mm)	11.25 (286mm)	
2 - 16LH	11.75 (298mm)	11.1563 (283mm)	

\*See page 1-37 for Selection and Part Number

## MORSE TAPER ADAPTER

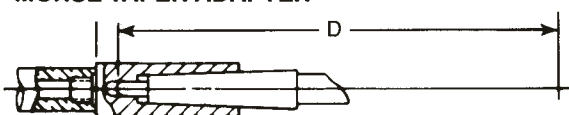

Bushing Thread	Dim. E No. 2 MT 619832	Dim. E No. 3 MT 619819	Dim. E No. 4 MT 619820
1 - 14LH	12 (305mm)	11.875 (301mm)	11.9375 (303mm)
1.25 - 12LH	12 (305mm)	11.875 (301mm)	11.9375 (303mm)
1.5 - 12LH	12 (305mm)	11.875 (301mm)	11.9375 (303mm)
2 - 16LH	11.875 (301mm)	11.8125 (299mm)	11.8125 (299mm)

## QUACKENBUSH™

### 230QGDAB-SU-MS Series

**Capacity:**

Aluminum – 1.25" (31.75mm)

Titanium – .875" (22.2mm)

**Stroke:**

Max – .125" (3.18mm)

Min. – Unlimited

- 230 series motor develops 2.3 nominal horsepower.
- Single push-button starts motor and engages drill feed mechanism.
- Externally replaceable shear pin provides gear protection if chips pack or cutter binds.
- Rapid advance with manual speed control and low torque clutch protection if cutter advances into workpiece.
- Easily adapted to oil hole drilling using a solid spindle and a fluid chuck, or with the use of an oil hole spindle and a fluid swivel.
- Stroke is adjustable by positioning the stop collar.
- Spindle continues to rotate in forward direction on return stroke to eliminate withdrawal spiral in hole.
- Rapid spindle retraction.
- Spindle can be retracted at any point during feed cycle by lifting retract lever.
- Precision depth control with automatic retract after preset dwell period. (When equipped with depth sensing nose assembly)
- Positive depth stop is adjustable for desired hole depth.
- Cutter automatically retracts if tool senses thrust overload.
- Motor shuts off automatically after retract.



230QGDAB-SU-MS

Model	Motor Configuration	Maximum Stroke		Weight*		Length		Spindle Speeds	Feed Per Revolution	Inlet	Minimum Hose Size
		in.	mm	lbs	kg	in.	mm				
230QGDAB-SU-MS	Piggy Back	NO LIMIT		17.5	7.9	27 .375	695	75, 97, 120, 150, 188, 240, 307	.0005, .001, .002, .003, .0045, .006, .008, .012	.5" NPT	.5"
230QGDAB-SU-MS	Piggy Back	NO LIMIT		16.25	7.4	25 .375	644	390, 480, 585, 680, 825, 960, 1155, 1500	.0005, .001, .002, .003, .0045, .006, .008, .012	.5" NPT	.5"
230QGDABV-SU-MS	Piggy Back	NO LIMIT		18.8	8.2	27 7/8	707	75/187, 150/375	.0005, .001, .002, .003, .0045, .006, .008, .012	.5" NPT	.5"
230QGDABV-SU-MS	Piggy Back	NO LIMIT		16.75	7.6	25 7/8	657	330/780, 600/1500	.0005, .001, .002, .003, .0045, .006, .008, .012	.5" NPT	.5"

\*Weight and Length will vary depending on rpm specified.  
 Rated tool performance at 90 PSIG measured at tool inlet with motor running.  
 When selecting speeds and feeds, see page I-5.  
 SEE PAGES I-11-I-13 FOR SAFETY PRECAUTIONS.

**WHEN ORDERING TOOL:**  
 Tool nose and spindle must be specified.  
 Standard tool noses, spindle guards and spindles are provided at no charge when ordered with tool. Select one tool nose and one spindle.  
 Other tool noses and spindles are available at extra charge.  
 Specify EITHER 2.25" L. H. External Thread OR 1.5625"-20 L.H. Internal Thread.



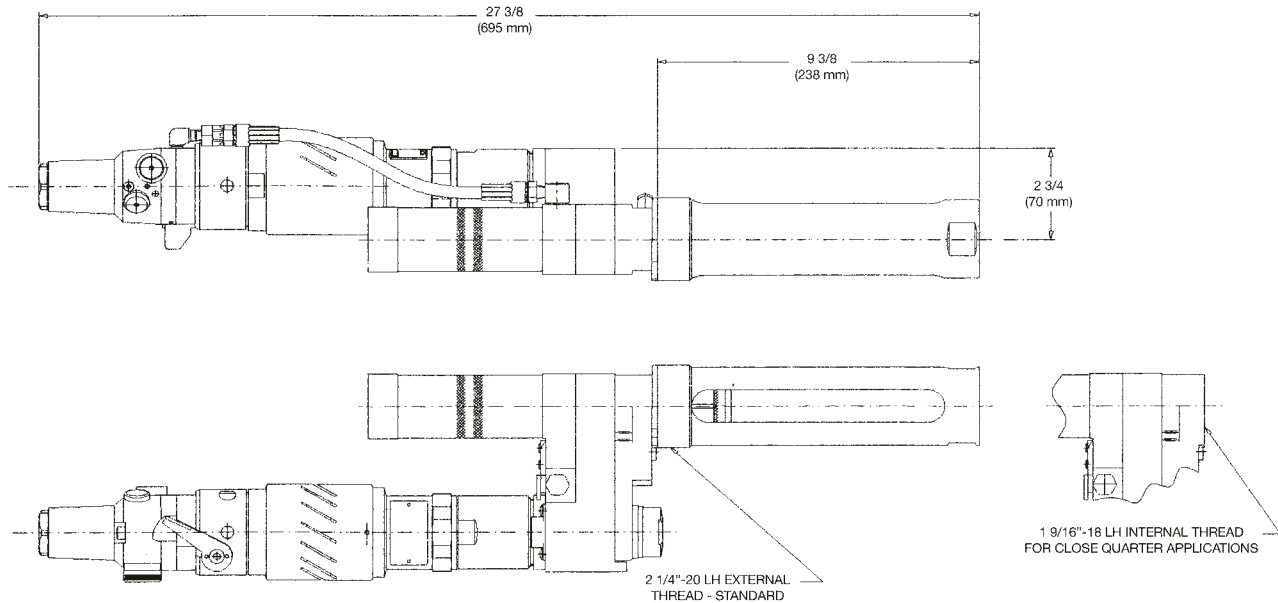

## STANDARD TOOL NOSE

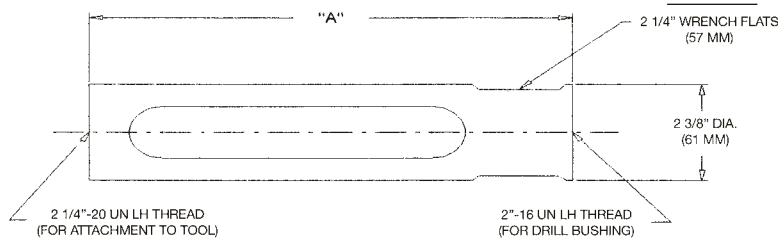

## STANDARD SPINDLES

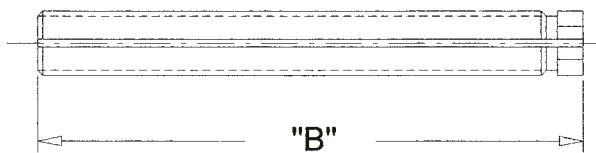

- 2.25"-20 L.H. Nose Thread Attachment on standard tool accepts S400 and S600 Tool Noses and accessories. For close quarter applications, a special tool with 1.5625"-20 L.H. Internal Nose Attachment Thread is available.
- With the 1.5625"-20 L.H. Internal Thread, order Nose Adapter (614244) to attach S150 and S275 (2" O.D.) Tool Noses and accessories, OR Nose Adapter (614228) to attach S400 and S600 (2.375" O. D.) Tool Noses and accessories. (See pg. 2-21)
- Nose Indexers - 1.5625"-20 Nose Thread use (381326; for 2.25"-20 L.H. Nose Thread use (381327) (NOTE: Tool must be equipped with 1.5625"-20 L.H. Nose Attachment Threads.)

## STEEL TOOL NOSES (Select One)

Length "A"	Thread	Part No.
<b>S400 SERIES</b>		
9.5" (241mm)	.75" - 16 L.H.	621235
9.5" (241mm)	1" - 14 L.H.	621236
9.5" (241mm)	1.25" - 12 L.H.	621237
9.5" (241mm)	1.5" - 12 L.H.	621238
9.375" (238mm)	2" - 16 L.H.	614751
<b>S600 SERIES</b>		
11.5" (282mm)	1" - 14 L.H.	621244
11.5" (282mm)	1.25" - 12 L.H.	621245
11.5" (282mm)	1.5" - 12 L.H.	621246
11.375" (279mm)	2" - 16 L.H.	614757

## SPINDLES (Select One)

Spindle Type	Length "B"	Max. Stroke	Thread Description	Part No.
Oil Hole	9" (229mm)	4" (103mm)	.5625"-18 Internal Thread with Counterbore and 118° Angle	382599
Oil Hole	9" (229mm)	4" (103mm)	.625"-18 Internal Thread with Counterbore and 118° Angle	382346
Solid	9" (229mm)	4" (103mm)	No. 2 Short Morse Taper with side Knock-Out	382628

- When adapting a 3-jaw chuck to .5625"-18 Internal Thread Spindle, order Chuck Adapter (623643) for .75" cap. chuck OR Chuck Adapter (619400) for .5" cap chuck. (See pgs. 1-36)
- Fluid Swivels used with oil hole spindles and selection of Fluid Chucks. (See pg. 1-37)
- Other Noses and Spindles are available at extra charge. (See pg. 2-21)

## QUACKENBUSH™

### 230QGDAB-SU-MS

#### Depth and Dwell Attachment

The Quackenbush Depth Control or Countersink Attachment is a high quality, precision attachment for the 230 Series Positive Feed Drill which is used to precisely control the depth of drilled and reamed, straight or tapered holes on both flat or contoured surfaces.

The attachment is also used for precision countersink operations. This attachment has been proven on the most demanding hole preparation jobs in the aircraft industry, and has earned the reputation for producing exceptionally high quality holes with precise depth accuracy, roundness and a high level of finish.

#### How the depth and dwell attachment operates

##### ■ Start

Threaded to the end of the Depth and Dwell Attachment is a DRILL BUSHING ③ which is used to secure the unit to the tooling fixture ②. A tubular SENSING SLEEVE ⑥ is piloted by and slides axially inside the DRILL BUSHING ③. The SENSING SLEEVE surrounds and pilots the CUTTER ⑦ and the SPINDLE ⑧. It is SPRING ④ biased to engage the WORKPIECE ① and seat against it ⑤. The primary function of the SENSING SLEEVE is to provide a positive, definite stopping surface that is a precise repeatable distance from the workpiece.

##### ■ Finish

Attached to SPINDLE ⑧ is a patented micrometer type, ADJUSTABLE ROTATING STOP ⑨ with a self-contained anti-friction bearing designed to engage the SENSING SLEEVE when the CUTTER has achieved the desired depth.

Once the pre-determined depth has been reached, the advancement of the CUTTER is stopped by the engagement of the ADJUSTABLE STOP on the SPINDLE contacting the SENSING SLEEVE. This allows the CUTTER to dwell (continue rotation without further feed) and produce the desired hole characteristics.

The Model 230 Drill (furnished under separate order) features automatic thrust activated retract, torque overload shear pin, and automatic motor stop after retract.

When mounted on the Model 230 Positive Feed Drill, the common SPINDLE ⑧ extends through and is driven by the right angle drill head.

Spindles (up to 15" long) will be hollow for coolant flow. A fluid inducer (Part No. 381213) may be purchased for the remote end of the spindle. Rear spindle guards must be used on all applications.

NOTE: Models designed for 1.186 maximum diameter cutters are common. Larger units for 1.750 maximum diameter cutters are available. Shortened models are available for short strokes in confined work areas.

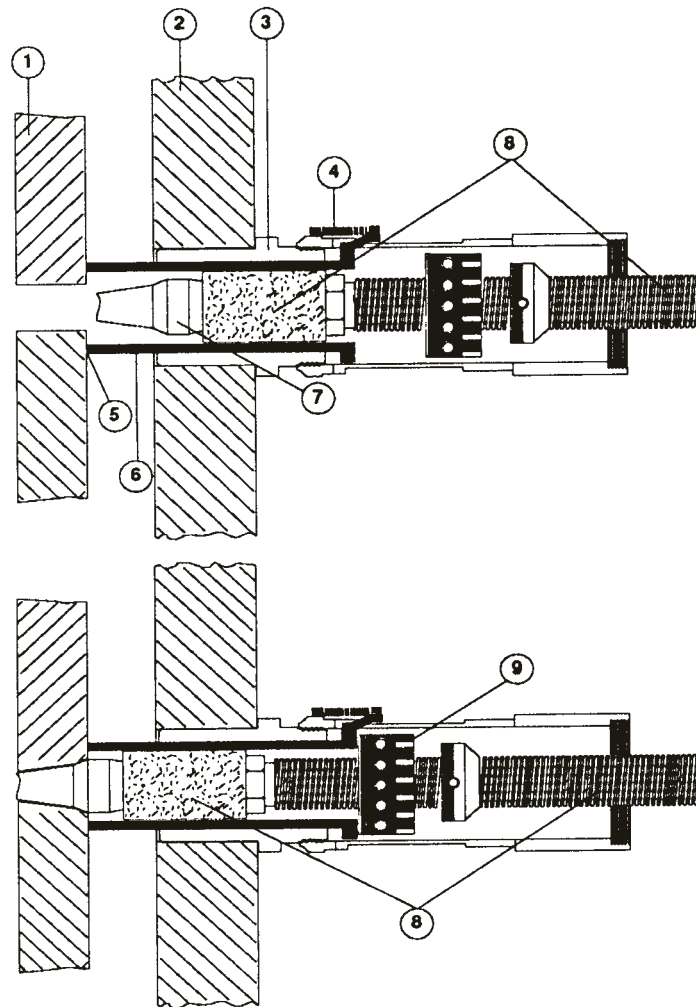

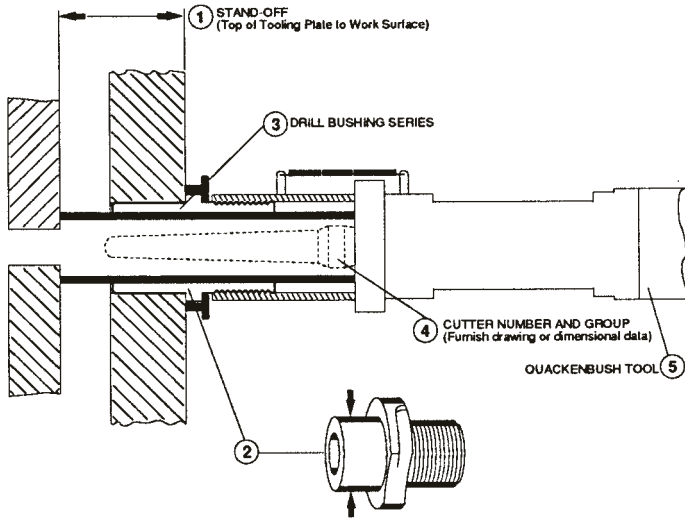

Depth and Dwell attachments are designed for each tooling application. The following information is required in order to obtain a quotation from the factory, Contact your local Quackenbush Specialist for assistance.

- ① Stand Off: \_\_\_\_\_ inches. (Minimum chip clearance .375")
- ② Drill Bushing Tip Outside Diameter: \_\_\_\_\_ inches.
- ③ Drill Bushing Series (Circle One):
- 2 Lock — 22,000, 23,00 & 24,000 Series
  - 3 Lock — 25,000, 26,000 Series
- ④ Cutter Information:
- Style (reference drawings at bottom of this page): \_\_\_\_\_
  - Furnish cutter Drawing or Dimensional Data (reference drawings at bottom of this page)
- A \_\_\_\_\_ F \_\_\_\_\_
- B \_\_\_\_\_ T \_\_\_\_\_ External Thread
- C \_\_\_\_\_ or \_\_\_\_\_
- D \_\_\_\_\_ T \_\_\_\_\_ Internal Thread
- E \_\_\_\_\_ Fluid Spindle: Yes \_\_\_\_\_ No \_\_\_\_\_
- ⑤ Nose Indexer: Yes \_\_\_\_\_ No \_\_\_\_\_
- ⑥ Quackenbush Tool Model No. \_\_\_\_\_

NOTE: • Important— If chip escape reliefs are required on the sensing sleeve, they must be specified when ordering. A drawing must be provided showing the exact location and type openings required.  
 • Some applications involving long cutters require that the tips of the cutter extend beyond the Dwell and Depth Attachment when the spindle is fully retracted.

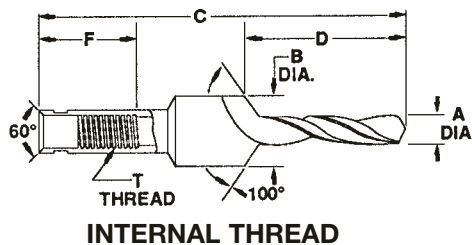
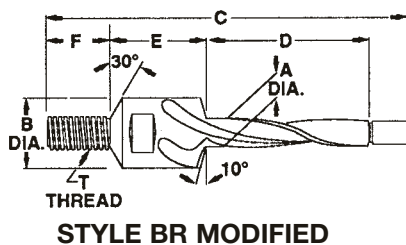
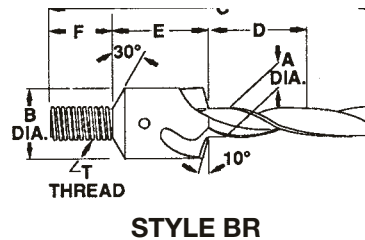
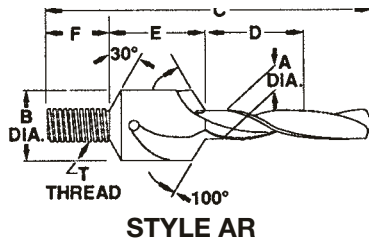
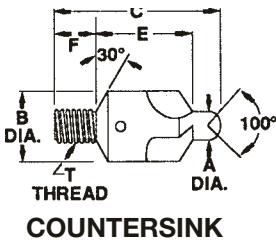

FOR OTHER CUTTER STYLES, FURNISH CUTTER DRAWING

# In-Line Tool Accessories

## Accessories for the No. 230 B & RA Series Right Angle Drills

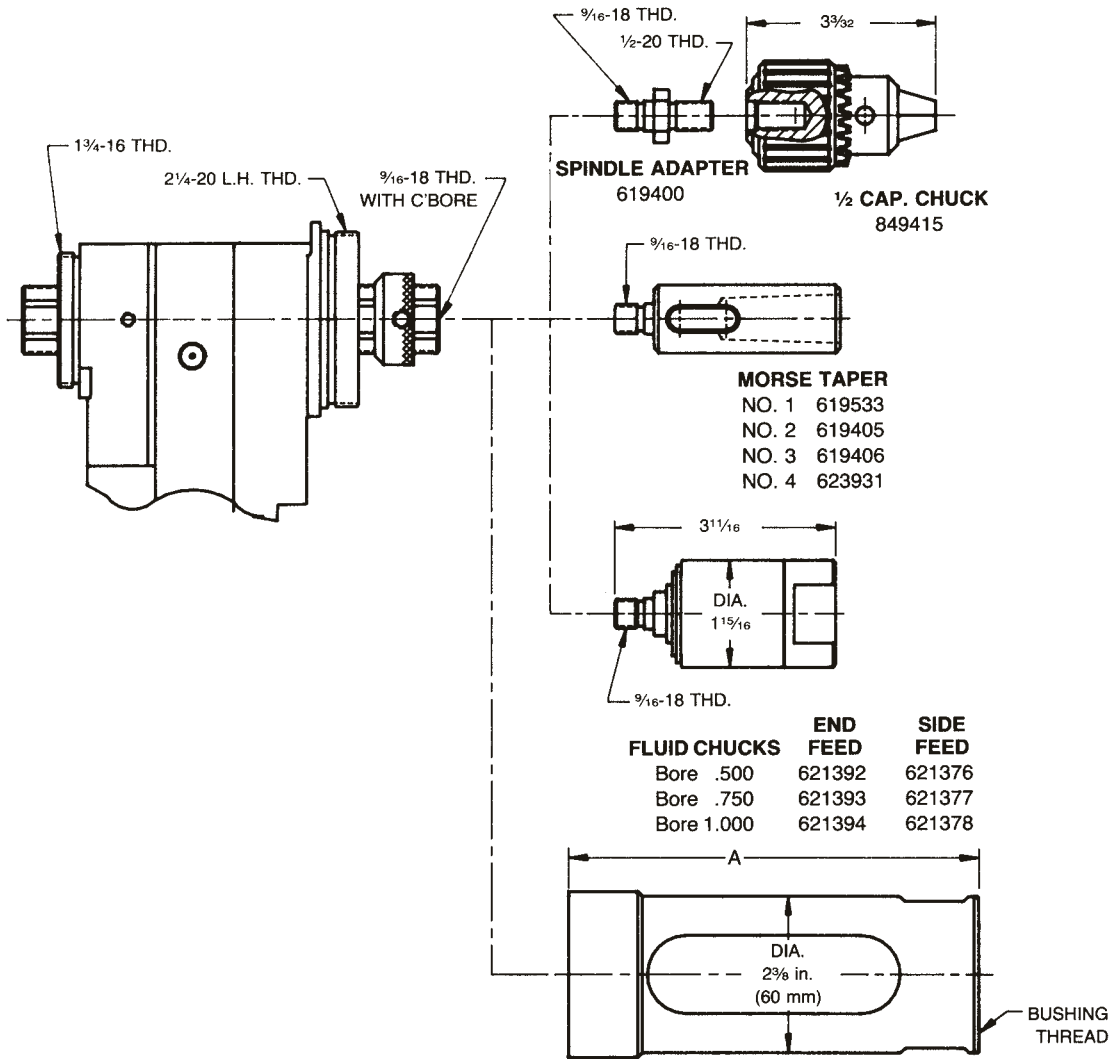

Bushing Thread	S400 Series		S600 Series	
	Dim. A	Part No.	Dim. A	Part No.
1" - 14 L.H.	9.5 in. (241mm)	661236	11.5 in. (292mm)	621244
1.25" - 12 L.H.	9.5 in. (241mm)	621237	11.5 in. (292mm)	621245
1.5" - 12 L.H.	9.5 in. (241mm)	621238	11.5 in. (292mm)	621246
2" - 16 L.H.	9.375 in. (238mm)	614751	11.375 in. (289mm)	614757

**Fluid Chucks**

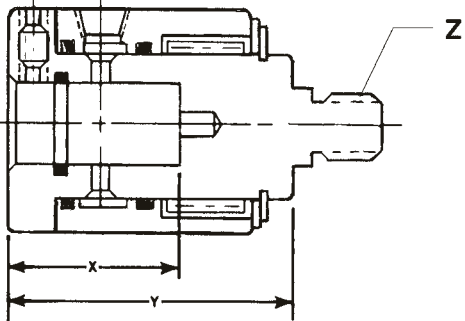

**Side Feed**

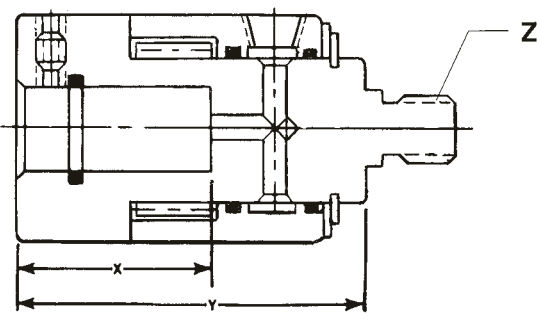

**End Feed**

Quackenbush Drill*	Bore Dia.	Side Feed			End Feed				
		Part No.	"X"	"Y"	"Z"	Part No.	"X"	"Y"	"Z"
S-125, S-300	250	621373	1.510	2.031	.375-24	621389	1.000	2.312	.375-24
S-265	.375	621374	1.510	2.031	.375-24	621390	1.000	2.312	.375-24
S-150, S-275	.500	621375	1.510	2.031	.375-24	621391	1.000	2.312	.375-24
S-400, S600	.500	621376	1.510	2.406	.5625-18	621392	1.437	3.000	.5625-18
S-400, S600	.750	621377	1.510	2.406	.5625-18	621393	1.687	3.000	.5625-18
S-400, S600	1.000	621378	1.510	2.406	.5625-18	621394	1.687	3.000	.5625-18
S-700, S750	1.000	621408	1.510	2.406	.75-16	621395	1.687	3.000	.75-16

\*Stroke length. Note: Dimensions X & Y are reference.

*Right Angle Positive Feed Tools*

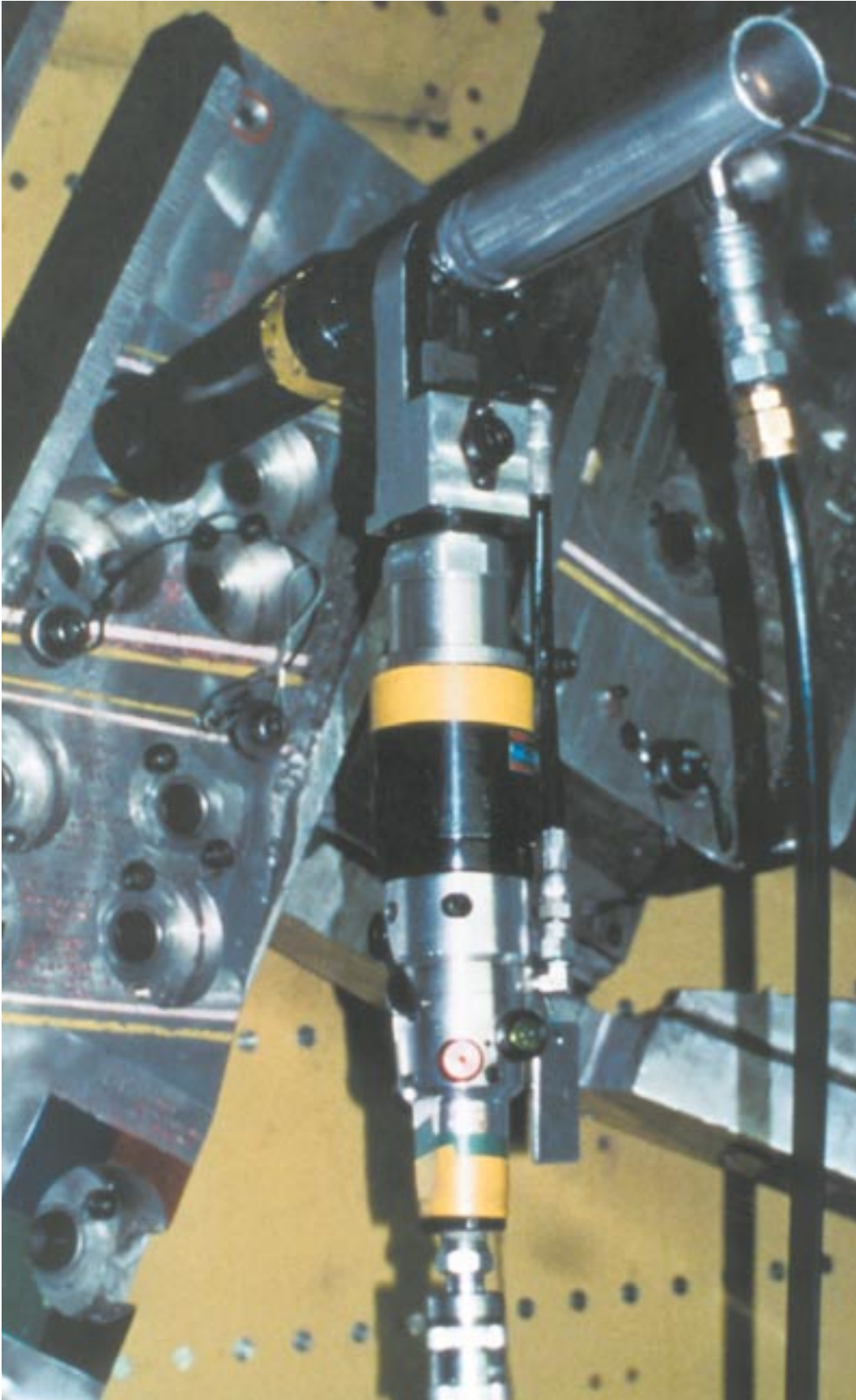

# Introduction

## Right Angle Positive Feed Tools

Our positive feed drill motors are available in both in-line and right angle configurations (*please also see the in-line tool section*), The right angle tools are rapidly growing in popularity due to their compact size, light weight and ease of operation.

In-line drills have a limited stroke, but with a right angle drill a deeper stroke can be achieved by simply applying a longer spindle and nosepiece. In addition, the fixtures do not have to be as robust with a right angle drill, which represents a significant cost savings. The tools themselves weigh less and in use are closer to the fixture, resulting in less deflection of the fixture. Right angle tools have also been shown to reduce operator fatigue.

In general, positive feed drills are used for the larger holes and heavier structures in the aircraft industry such as the spars and the ribs, primarily in landing gear, wing and fuselage joints.

Positive feed drills produce a hole in a predictable and constant time. With each revolution of the spindle,

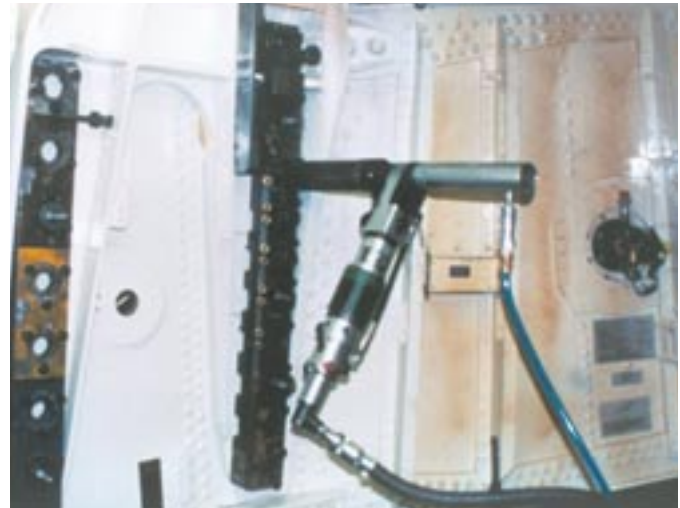

the cutter travels a precise distance, i.e., one-thousandth of an inch or three-thousandths of an inch depending on the settings. This is true whether the tool is drilling air or drilling a tough alloy. The benefit is that burrs caused by surging of the cutter on the exit side of the cycle are virtually eliminated.

Since the cutter advances a precise distance with each revolution, the cutter does not rotate without cutting. This reduces heat and deformation, resulting in less chance of the material work hardening.

Many of the accessories for our in-line and right angle tools are interchangeable, such as chucks, nose pieces, motors and gears.

### How Positive Feed Right Angle Drills Operate

The fixed rate of spindle advancement (feed) for each rotation of the drill spindle in right angle tools is accomplished by differential gearing. The spindle of a right angle drill has external left-hand threads and four drive grooves that run the length of the spindle. The spindle fits into and through two gears: the spindle drive gear and the spindle feed gear.

The spindle drive gear has internal male splines that engage the drive grooves on the spindle. When the air motor is turned on, the spindle drive gear rotates, turning the spindle.

The spindle feed gear is threaded internally to match the external thread of the spindle, and its function is to

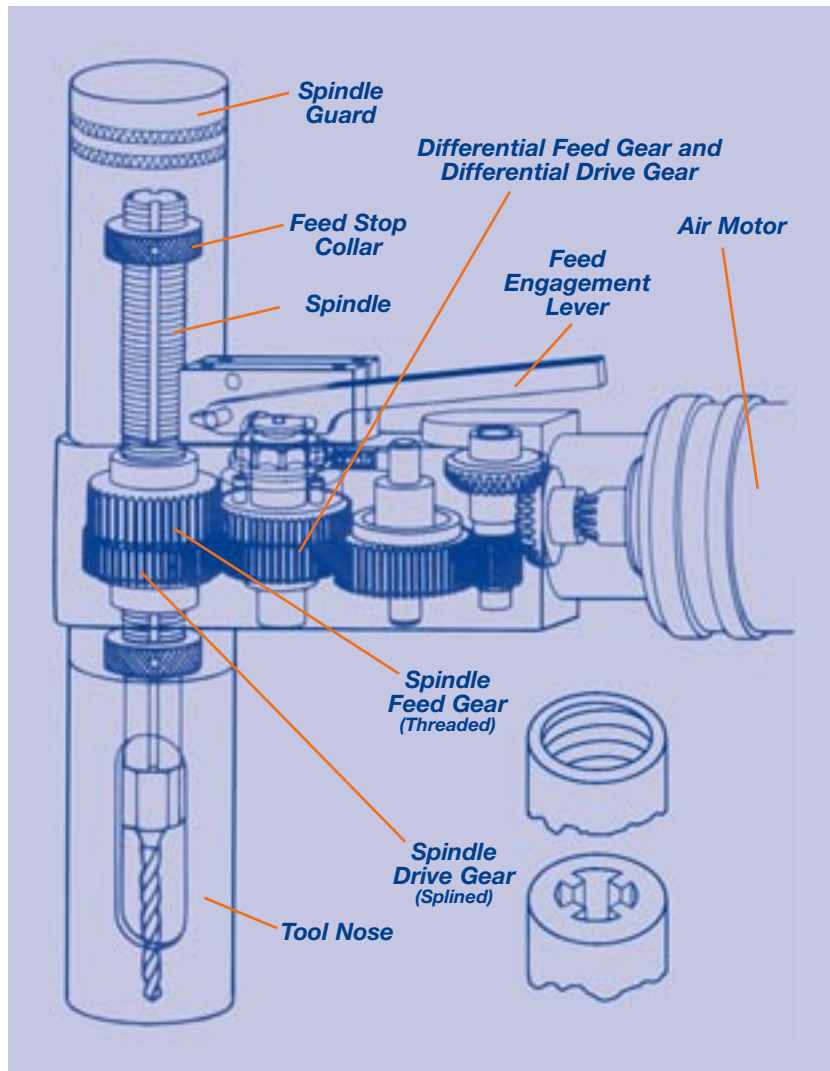

advance or retract the spindle. When this gear rotates faster than the spindle, the spindle will feed. When it stops, the spindle will retract. The desired feed rate is obtained by the differential gear ratio between the spindle drive and spindle feed gears.

At the completion of the drilling cycle, the feed stop collar contacts the feed engagement lever, lifting the differential feed gear and locking it in a stationary position. With the spindle continuing to rotate in a forward direction and the spindle feed gear held stationary, the spindle automatically retracts. This action occurs approximately three times faster than the advancement cycle. Depending on the positive feed model selected, the tool is shut down either manually or automatically.

### Taper-Lok Fixturing

Customized fixtures are constructed to accept Taper-Lok Bushing Tips. Advanced Drilling Equipment tools with the Bushing Tips are inserted into the fixture, twisted and cam-locked into place.

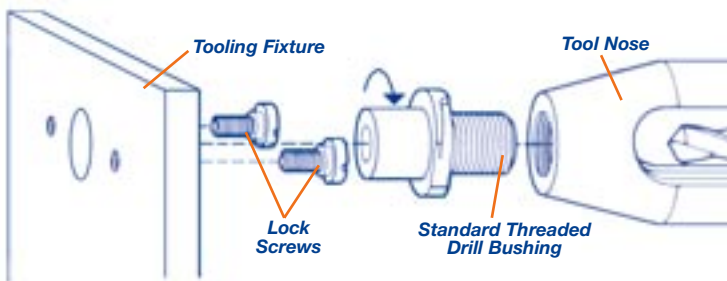

The Bushing Tip's tapered flanges fit under the shoulder of lock screws in the fixture. The Bushing Tip holds the tool in alignment and absorbs the thrust and torque of drilling. At the completion of the drilling cycle, the tool is rotated to unlock, withdrawn from the fixture and moved to the next position.

Several different types of Taper-Lok Fixturing are available. The following are the most common.

**Lock Liners**

Method for mounting to a fixture. A hole is bored in the jig to accommodate the lock liner bushing. The lock ring holds the lock liner bushing in position in the jig.

**Direct Mounting**

The Serrated Liner is used in potted or cast-in-place installations.

**Direct Mounting**

Most common mounting method has lock screws mounted directly into the fixture plate. The shank of the drill bushing tip fits directly into a bored hole in the fixture plate.

**Lock Strip**

This method for closely spaced holes employs a lock strip along each side of the row of holes in the fixture plate. The flanges on the Drill Bushing Tip lock under the extended edges of the lock strip.

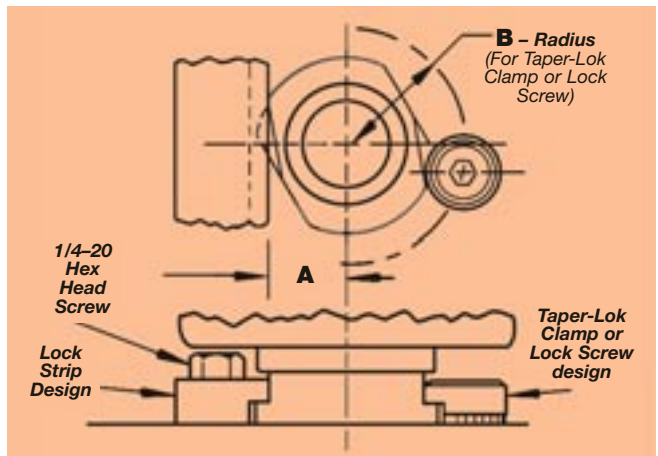

### Location Data for Taper-Lok Clamp, Lock Screw, and Lock Strip Mounting

Drill Bushing Tip Series	A	B	Tool Nose Thread (I.D.)
21000	.312	.625	3/4-16
22000	.609	.922	1-14
23000	.734	1.047	1 1/4-12
24000	.859	1.172	1 1/2-12
25000	None	1.562	2-16



## QUACKENBUSH™

### 15QDA-RAB-SU-RS Series

**Capacity:**

- Aluminum – .5625" (14.3mm)
- Titanium – .4375" (11.1mm)
- Steel – .4375" (11.1mm)

**Stroke:**

- Unlimited
- Min. – .375" (9.5mm)

- 15 series motor develops 1.0 nominal horsepower.
- Right angle tool designed for close quarter operation.
- Utilizes spindles of varying lengths to provide unlimited hole depth capability.
- Tool utilizes spindles which accommodate threaded shank, straight shank and morse taper.
- Easily adapted to oil hole drilling using a solid spindle and a fluid chuck, or with the use of an oil hole spindle and a fluid swivel.
- Stroke is adjustable by positioning the stop collar.
- Spindle continues to rotate in forward direction on return stroke to eliminate withdrawal spiral in hole.
- Rapid spindle retraction.
- Spindle can be retracted at any point during feed cycle by lifting retract lever.
- Automatic retract stop with protective rolling impulse clutch prevents accidental jamming of spindle at end of retract.
- Feed is engaged by pressing down on feed engagement lever.
- Tool is manually shut off at completion of drill cycle.

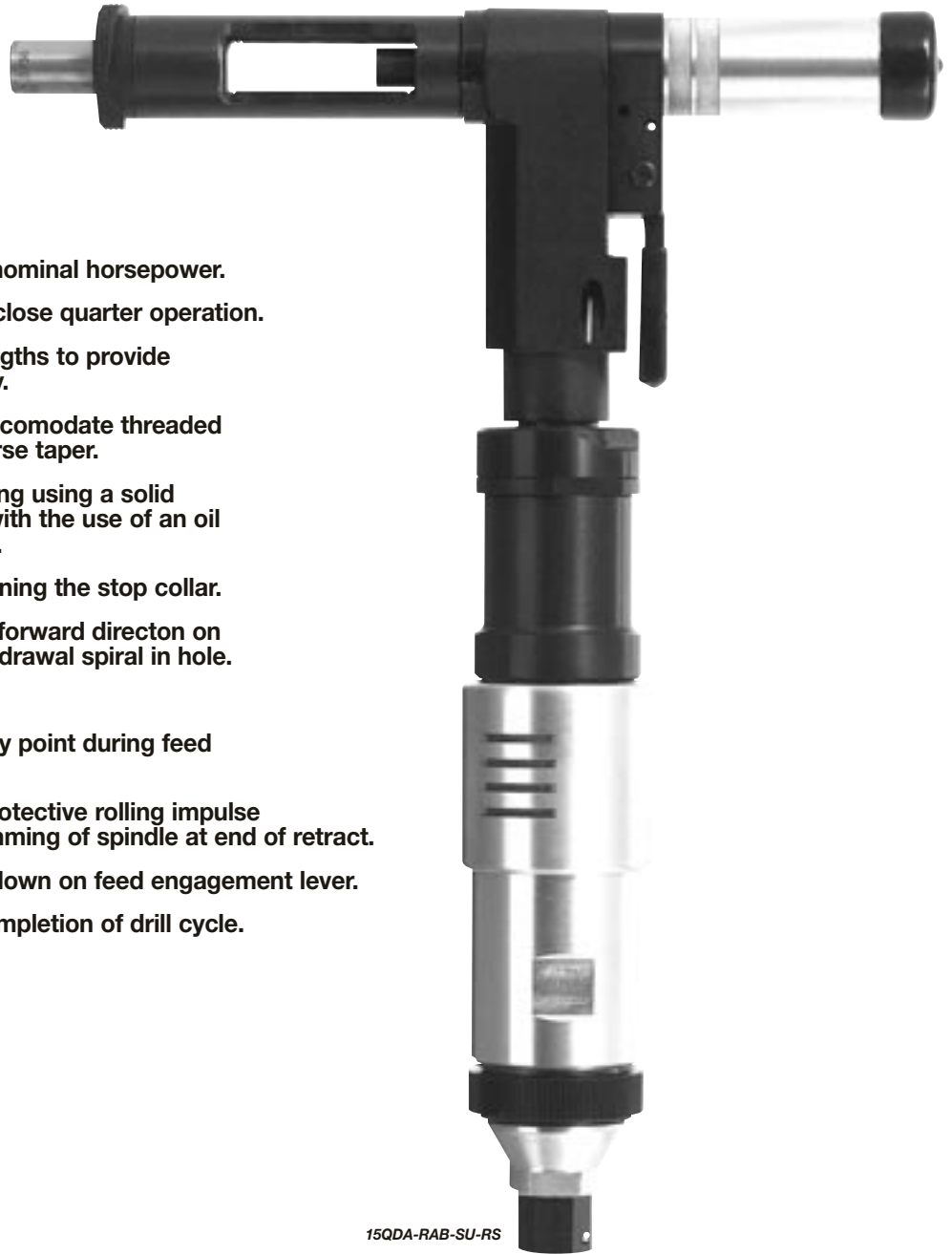

15QDA-RAB-SU-RS

Model	Motor Configuration	Maximum Stroke		Weight		Maximum Length		Spindle Speeds	Feed Per Revolution	Inlet	Minimum Hose Size
		in.	mm	lbs	kg	in.	mm				
15QD-RAB-SU-RS	Right Angle	No Limit		5	2.27	13 3/8	34	160, 265, 335, 465, 660, 1000, 1650	.0005, .001, .002, .003, .006	.375" NPT	.375"

**STANDARD EQUIPMENT:**

Noses and spindles must be specified when ordering.  
 Rated tool performance at 90 PSIG measured at tool inlet with motor running.  
 When selecting speeds and feeds, see page I-5.  
 Mist lubricator (631298) may be ordered.  
 SEE PAGES I-11-I-13 FOR SAFETY PRECAUTIONS.  
 SEE PAGE 2-20 – 2-23 FOR TOOLING ACCESSORIES.

**WHEN ORDERING TOOL:**

Tool nose and spindle must be specified. Standard tool noses, spindle guards and spindles are provided at no charge when ordered with tool. Select one tool nose and one spindle. Other tool noses and spindles are available at extra charge – see page 2-24.

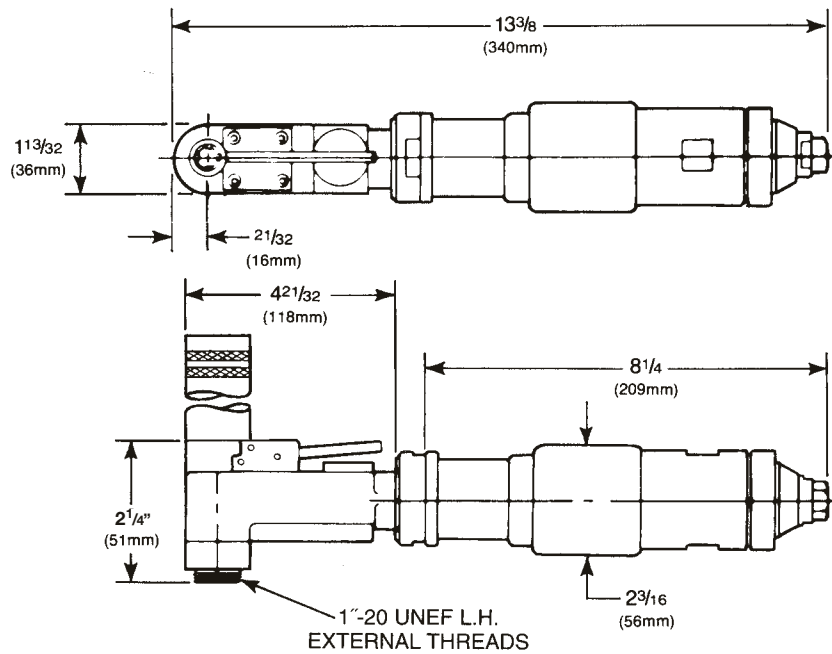

• **STANDARD TOOL NOSE (PART NO. 614905)**

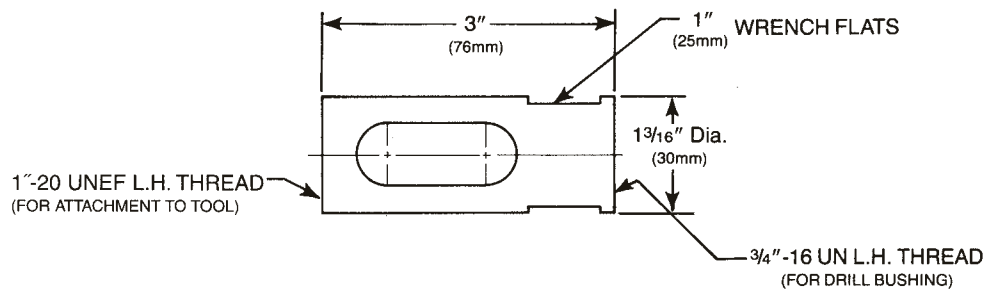

• **STANDARD SPINDLES**

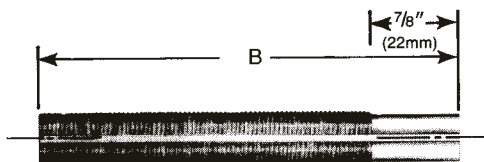

**SPINDLES (Select One)**

Spindle Type	Length "B"	Max. Stroke	Thread Description	Part No.
Solid	4" (101mm)	1.12" (29mm)	.25"-28 Internal Thread	623266
Solid	4" (101mm)	1.12" (29mm)	.375"-24 Internal Thread with Counterbore	615915

- Order Tool Nose Adapter (614722) to attach S125 & S300 Tool Noses (1.75" O.D.) and accessories. (See page 2-24)
- Order Tool Nose Adapter (614973) to attach S150 & S275 Tool Noses (2" O. D.) and accessories (See page 2-24)
- Order Chuck Adapter (619136) when utilizing 3-jaw chuck with .375 -24 Internal Thread Spindles.

- Fluid Swivel (631256) used with Oil Hole Spindles, and selection of Fluid Chucks. (See page 2-23)
- Fluid Chucks used with .375 -24 Internal Thread Spindles.
- Other Noses and Spindles are available as required (see page 2-24).
- Nose Indexer (631249)

## QUACKENBUSH™

### 15QD-RAB-SU-RS-RF Series Back Spotfacer

**Stroke:**

Min. - .375" (9.5mm)

Max. - Unlimited

- 15 series motor develops 1.0 nominal horsepower.
- Right angle tool designed for close quarter operation.
- Stroke is adjustable by positioning the stop collar.
- Spindle continues to rotate in forward direction on return stroke.
- Rapid spindle retraction.
- Spindle can be retracted at any point during feed cycle by lifting retract lever.
- Automatic retract stop with protective rolling impulse clutch prevents accidental jamming of spindle at end of retract.
- Feed is engaged by pressing down on feed engagement lever.
- Tool is manually shut off at completion of drill cycle.
- Spindle guard protects operator.



15QD-RAB-SU-RS-RF

Model	Motor Configuration	Maximum Stroke		Weight		Maximum Length		Spindle Speeds	Feed Per Revolution	Inlet	Minimum Hose Size
		in.	mm	lbs	kg	in.	mm				
15QD-RAB-SU-RS-RF	Right Angle	No Limit		5	2.27	13 3/8	34	160, 265, 335, 465, 660 1000, 1650	.0005, .001, .002, .003, .006	.375" NPT	.375"

**STANDARD EQUIPMENT:**

Noses and spindles must be specified when ordering.  
Rated tool performance at 90 PSIG measured at tool inlet with motor running.

When selecting speeds and feeds, see page I-5.  
SEE PAGES I-11-I-13 FOR SAFETY PRECAUTIONS.  
SEE PAGE 2-20 - 2-23 FOR TOOLING ACCESSORIES.

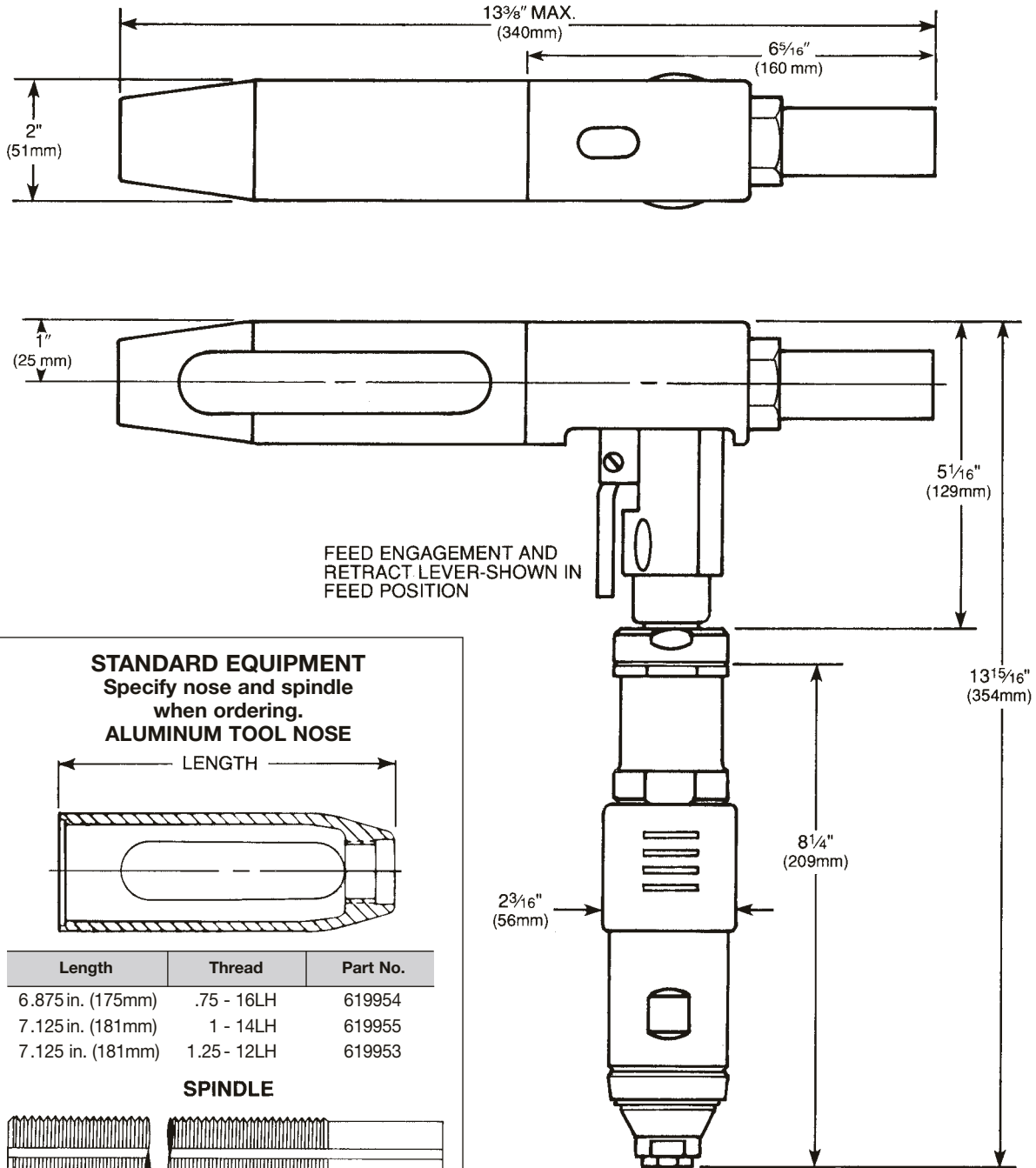

**STANDARD EQUIPMENT**  
Specify nose and spindle  
when ordering.  
**ALUMINUM TOOL NOSE**

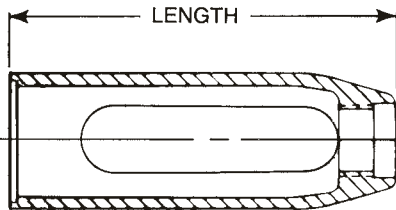

Length	Thread	Part No.
6.875 in. (175mm)	.75 - 16LH	619954
7.125 in. (181mm)	1 - 14LH	619955
7.125 in. (181mm)	1.25 - 12LH	619953

**SPINDLE**

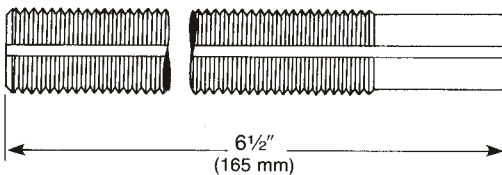

THREAD: .5- 22 **R.H.** Thread  
INTERNAL THREAD:  
.375 - 24 with Counterbore  
MAX. STROKE; 3.626" (92MM)  
PART NO: 624146-7

## QUACKENBUSH™

### 140QGDA-RA-SU-MS Series

**Capacity:**

- Aluminum – .5625" (14.3mm)
- Titanium – .4375" (11.1mm)
- Steel – .4375" (11.1mm)

**Stroke:**

- Min. – .3125" (8mm)
- Max. – Unlimited

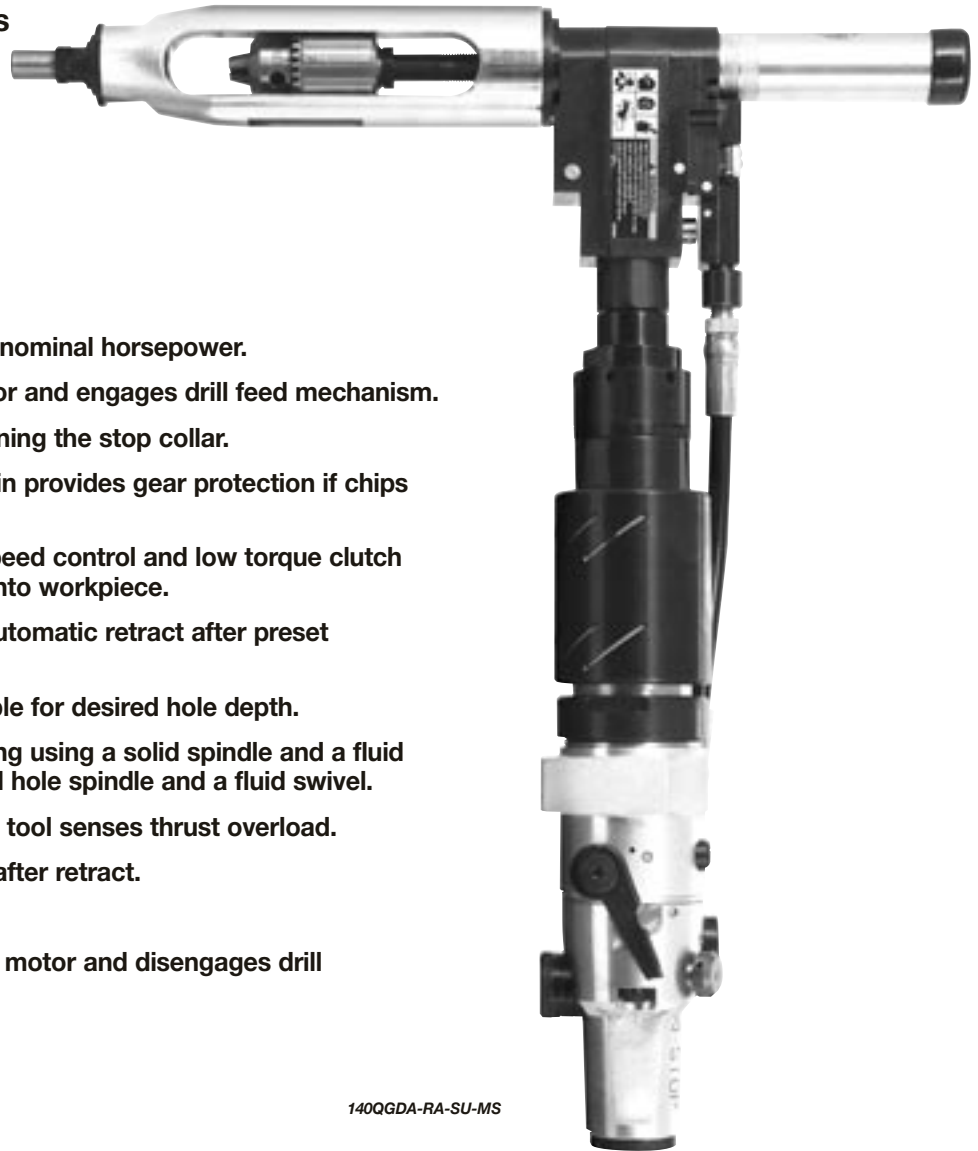

140QGDA-RA-SU-MS

- 140 series motor develops 1.4 nominal horsepower.
- Single push-button starts motor and engages drill feed mechanism.
- Stroke is adjustable by positioning the stop collar.
- Externally replaceable shear pin provides gear protection if chips pack or cutter binds.
- Rapid advance with manual speed control and low torque clutch protection if cutter advances into workpiece.
- Precision depth control with automatic retract after preset dwell period.
- Positive depth stop is adjustable for desired hole depth.
- Easily adapted to oil hole drilling using a solid spindle and a fluid chuck, or with the use of an oil hole spindle and a fluid swivel.
- Cutter automatically retracts if tool senses thrust overload.
- Motor shuts off automatically after retract.
- Auxilliary manual retract lever.
- Emergency push-button stops motor and disengages drill feed mechanism.

Model	Motor Configuration	Maximum Stroke		Weight		Maximum Length		Spindle Speeds	Feed Per Revolution	Inlet	Minimum Hose Size
		in.	mm	lbs	kg	in.	mm				
140QGDA-RA-SU-MS	Right Angle	No Limit		10.75	4.88	19.875	505	75, 120, 160, 200, 380, 580, 1000	.0005, .001, .002, .003, .006	.375" NPT	.5"
140QDA-RA-SU-MS	Right Angle	No Limit		10.75	4.88	19.875	505	75, 120, 160, 200, 380, 580, 1000	.0005, .001, .002, .003, .006	.375" NPT	.5"

**STANDARD EQUIPMENT:**

Noses and spindles must be specified when ordering.  
 Rated tool performance at 90 PSIG measured at tool inlet with motor running.  
 When selecting speeds and feeds, see page I-5.  
 SEE PAGES I-11-I-13 FOR SAFETY PRECAUTIONS.  
 SEE PAGE 2-20 – 2-23 FOR TOOLING ACCESSORIES.

**WHEN ORDERING TOOL:**

Tool nose and spindle must be specified. Standard tool noses, spindle guard and spindle are provided at no charge when ordered with tool. Select one tool nose and one spindle.  
 Other tool noses and spindles are available at extra charge – see page 2-24.

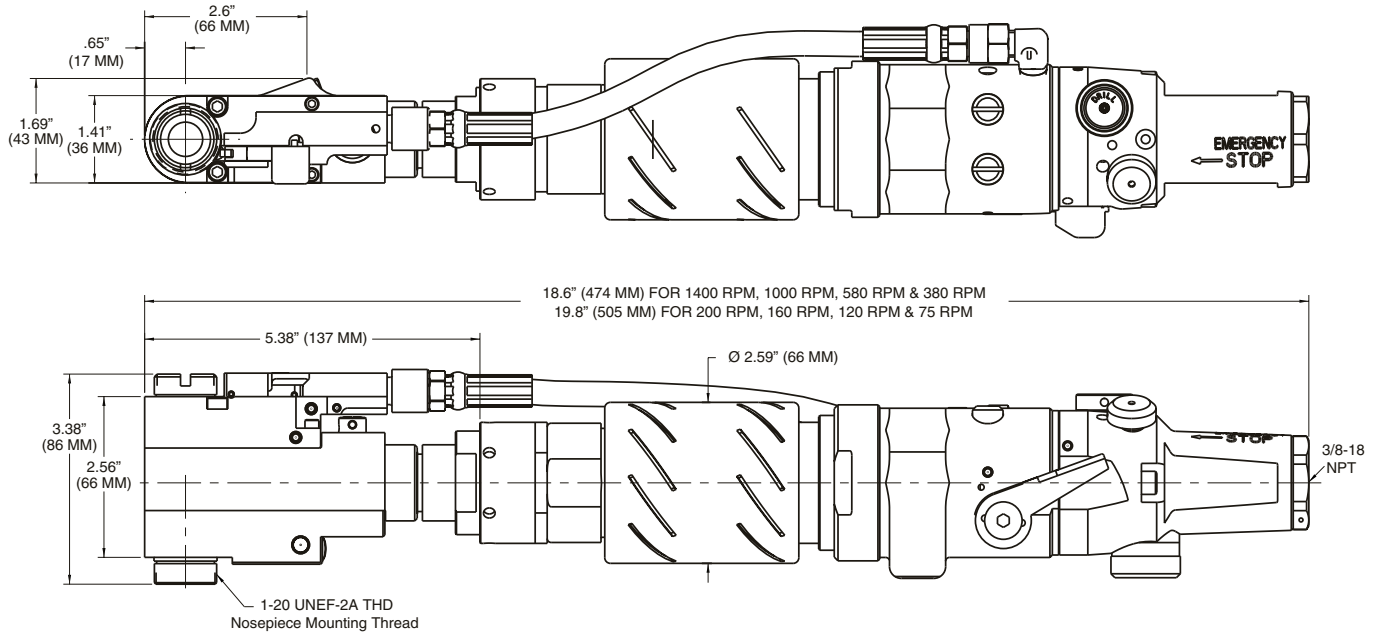

• **STANDARD TOOL NOSE (PART NO. 614919)**

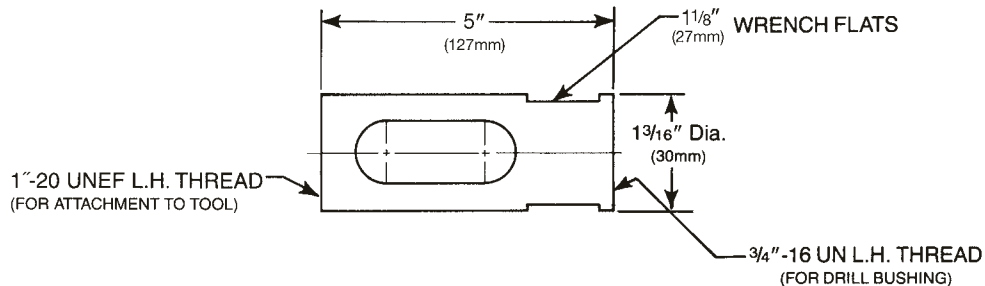

• **STANDARD SPINDLES**

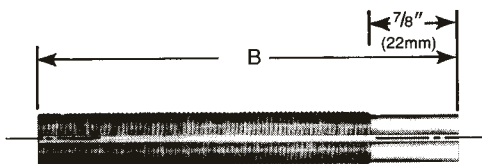

**SPINDLES (Select One)**

Spindle Type	Length "B"	Max. Stroke	Thread Description	Spindle Part No.	Spindle Guard No.
Solid	6" (152mm)	2.75" (70mm)	.375"-24 Internal Thread with Counterbore	615747	624342
Oil Hole	6" (152mm)	2.75" (70mm)	.375"-24 Internal Thread with Counterbore	623812	624332

- Order Tool Nose Adapter (629222) to attach S125 & S300 Tool Noses (1.75" O.D.) and accessories. (See page 2-24)
- Order Tool Nose Adapter (629224) to attach S150 & S275 Tool Noses (2" O. D.) and accessories (See page 2-24)
- Order Chuck Adapter (619136) when utilizing 3-jaw chuck with .375 -24 Internal Thread Spindles.

- Fluid Swivel (631256) used with Oil Hole Spindles, and selection of Fluid Chucks. (See page 2-23)
- Fluid Chucks used with .375 -24 Internal Thread Spindles.
- Other Noses and Spindles are available as required (see page 2-24).
- Nose Indexer (631864)

## QUACKENBUSH™

### 158QGDA-15RAB-SU-RS Series

Capacity:  
Aluminum - .5625"  
(14.28mm)

Stroke:  
Unlimited  
Min. - .375"

- 158 series motor develops 1.6 nominal horsepower.
- Right angle tool designed for close quarter operation.
- Utilizes spindles of varying lengths to provide unlimited hole depth capability.
- Tool utilizes spindles which accommodate threaded shank, straight shank and Morse Taper.
- Easily adapted to oil hole drilling using a solid spindle and a fluid chuck, or with the use of an oil hole spindle and a fluid swivel.
- Stroke is adjustable by positioning the stop collar.
- Spindle continues to rotate in forward direction on return stroke to eliminate withdrawal spiral in hole.
- Rapid spindle retraction.
- Spindle can be retracted at any point during feed cycle by lifting retract lever.
- Automatic retract stop with protective rolling impulse clutch prevents accidental jamming of spindle at end of retract.
- Feed is engaged by pressing down on feed engagement lever.
- Tool is manually shut off at completion of drill cycle.

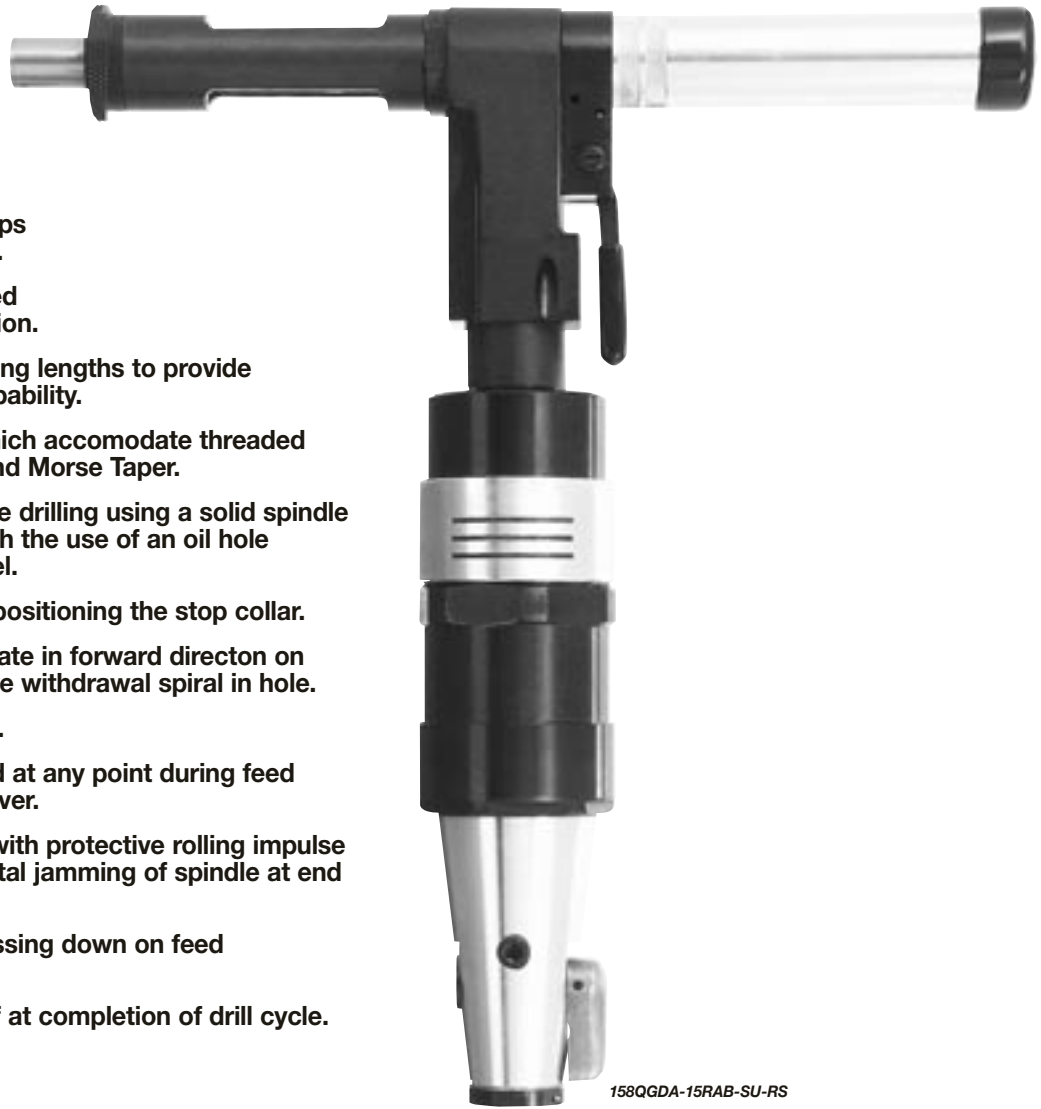

158QGDA-15RAB-SU-RS

Model	Motor Configuration	Maximum Stroke		Weight		Maximum Length		Spindle Speeds	Feed Per Revolution	Inlet	Minimum Hose Size
		in.	mm	lbs	kg	in.	mm				
15QGD-15RAB-SU-RS	Right Angle	No Limit		9.25	4.2	16 3/16	411	1000, 2000	.0005, .001, .002	.375" NPT	.5"

#### STANDARD EQUIPMENT:

Noses and spindles must be specified when ordering.  
Rated tool performance at 90 PSIG measured at tool inlet with motor running.  
When selecting speeds and feeds, see page I-5.  
SEE PAGES I-11-I-13 FOR SAFETY PRECAUTIONS.  
SEE PAGE 2-20 - 2-23 FOR TOOLING ACCESSORIES.

#### WHEN ORDERING TOOL:

Tool nose and spindle must be specified. Standard tool nose, spindle guard and spindle are provided at no charge when ordered with tool. Select one tool nose and one spindle.  
Other tool noses and spindles are available at extra charge — see page 2-24.

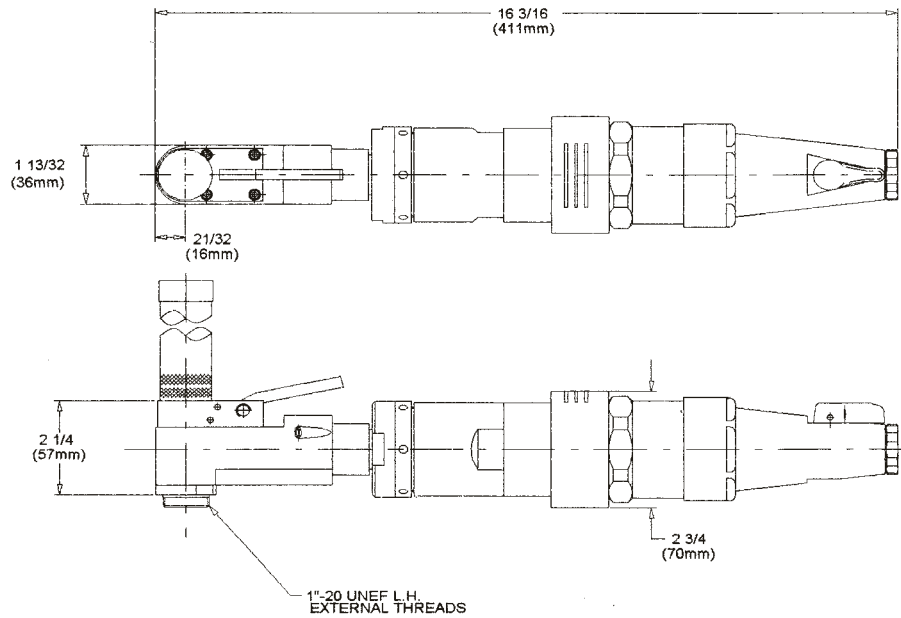

## STANDARD STEEL TOOL NOSE (Part No. 615460)

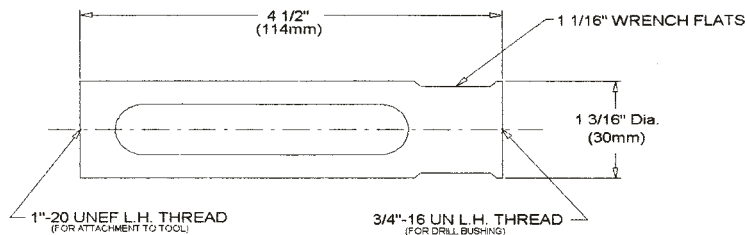

## STANDARD SPINDLES

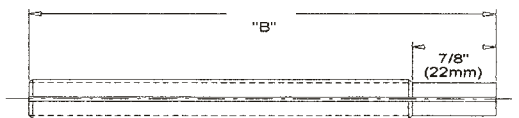

## SPINDLES (Select One)

Spindle Type	Length "B"	Max. Stroke	Thread Description	Part No.
Solid	6" (152mm)	3.12" (79.4mm)	.375"-24 Internal Thread with Counterbore	615747
Oil Hole	6" (152mm)	3.12" (79.4mm)	.375"-24 Internal Thread with Counterbore	623812

- Order Tool Nose Adapter (614722) to attach S125 & S300 Tool Noses (1.75" O.D.) and accessories. (See page 2-24)
- Order Tool Nose Adapter (614973) to attach S150 & S275 Tool Noses (2" O. D.) and accessories (See page 2-24)
- Order Chuck Adapter (619136) when utilizing 3-jaw chuck with .375 -24 Internal Thread Spindles.

- Fluid Swivel (631256) when used with Oil Hole Spindles, and selection of Fluid Chucks used with .375 -24 Internal Thread Spindles. (See page 2-23)
- Other Noses and Spindles are available as required (see page 2-24).
- Nose Indexer (631249)



## QUACKENBUSH™

### 158QGDA-RAD-SU-RS Series

**Capacity:**

- Aluminum - 1.25" (32mm)
- Titanium - 1" (25.4mm)
- Steel - 1" (25.4mm)

**Stroke:**

- Min. - .5" (12.7mm)
- Max. - Unlimited

- 158 series motor develops 1.6 nominal horsepower.
- Spindle rotates in forward direction during return stroke.
- Rapid spindle retraction.
- Use of spindles of varying lengths enables tool to drill holes in confined quarters.
- Easily adapted to oil hole drilling using a solid spindle and a fluid chuck, or with the use of an oil hole spindle and a fluid swivel.
- Tool utilizes spindles which accommodate threaded shank, Morse Taper, straight shank, reamers and fluid chucks.
- Spindle begins to rotate when motor is turned on. Tool begins to feed when feed control button is depressed.
- Spindle may be retracted at any point during drilling cycle.
- At end of stroke, stop collar on spindle trips retract lever, causing the spindle to return.
- Tool must be manually shut off.
- Automatic retract stop with protective rolling impulse clutch prevents accidental jamming of spindle at end of retract.
- Spindle guard protects operator.

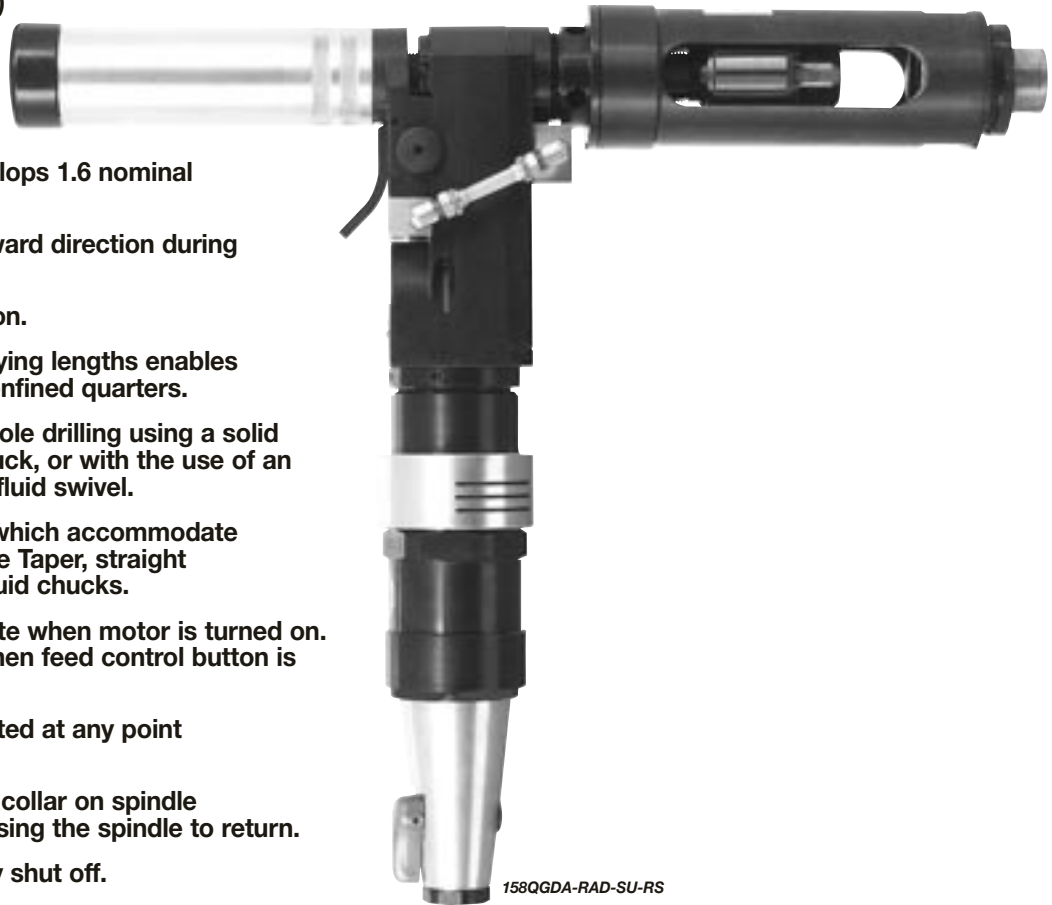

158QGDA-RAD-SU-RS

Model	Motor Configuration	Maximum Stroke		Weight		Spindle Speeds	Feed Per Revolution	Inlet	Minimum Hose Size
		in.	mm	lbs	kg				
15QGDA-RAD-SU-RS	Right Angle	No Limit		12.5	5.67	47, 56, 70, 94, 110, 120, 140, 185, 194, 230, 288, 380, 388, 460, 485, 570, 760, 950	.0005, .001, .002, .0035, .0055, .0075	.375" NPT	.5"
15QGDAV-RAD-SU-RS	Right Angle	No Limit		12.5	5.67	47/120, 92/230, 194/485, 380/950	.0005, .001, .002, .0035, .0055, .0075	.375" NPT	.5"

**STANDARD EQUIPMENT:**

Noses and spindles must be specified when ordering.  
 Rated tool performance at 90 PSIG measured at tool inlet with motor running.  
 When selecting speeds and feeds, see page I-5.  
 Mist lubricator (631298-7) may be ordered.  
 SEE PAGES I-11-I-13 FOR SAFETY PRECAUTIONS.  
 SEE PAGE 2-20 – 2-23 FOR TOOLING ACCESSORIES.

**WHEN ORDERING TOOL:**

Tool nose and spindle must be specified. Standard tool noses, spindle guards and spindles are provided at no charge when ordered with tool. Select one tool nose and one spindle. Other tool noses and spindles are available at extra charge – see page 2-24.

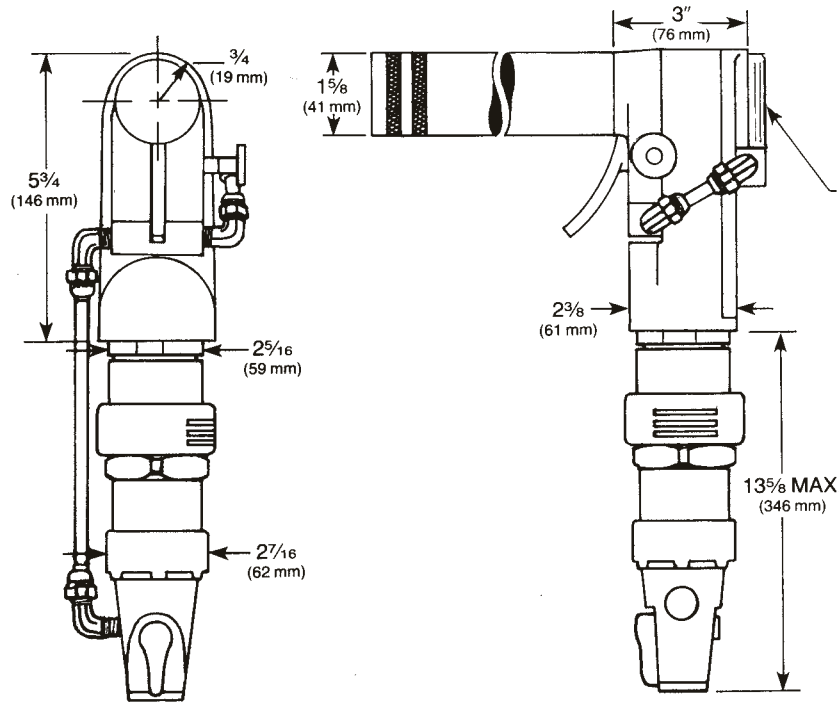

WHEN ORDERING: SPECIFY EITHER  
1 5/16"-20 OR 2 1/4"-20 NOSE  
THREAD ATTACHMENT

## STANDARD STEEL TOOL NOSE

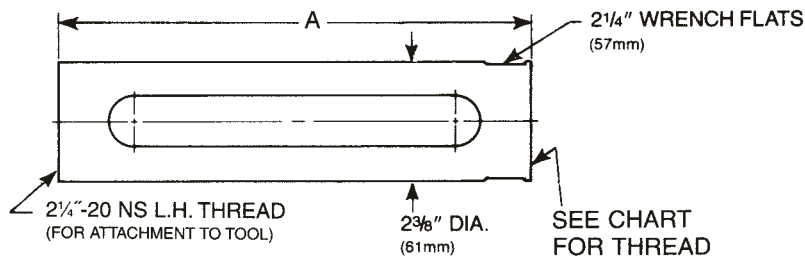

## STANDARD SPINDLES

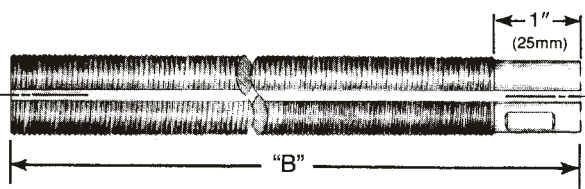

## STEEL TOOL NOSES (Select One)

Length "A"	Thread	Part No.
------------	--------	----------

### S400 SERIES

9.5" (241mm)	.75" - 16 L.H.	621235
9.5" (241mm)	1" - 14 L.H.	621236
9.5" (241mm)	1.25" - 12 L.H.	621237
9.5" (241mm)	1.5" - 12 L.H.	621238
9.375" (238mm)	2" - 16 L.H.	614751

### S600 SERIES

11.5" (282mm)	1" - 14 L.H.	621244
11.5" (282mm)	1.25" - 12 L.H.	621245
11.5" (282mm)	1.5" - 12 L.H.	621246
11.375" (279mm)	2" - 16 L.H.	614752

## SPINDLES (Select One)

Spindle Type	Length "B"	Max. Stroke	Thread Description	Part No.
Oil Hole	9.25" (235mm)	5.5" (140mm)	.5625"-28 Internal Thread with Counterbore and 118° Angle	623955
Oil Hole	9.25" (235mm)	5.5" (140mm)	.625"-24 Internal Thread with Counterbore and 118° Angle	615964
Solid	9" (229mm)	5.25" (133mm)	No. 2 Short Morse Taper with Side Knock-Out	614470
Solid	9" (229mm)	5.25" (133mm)	.5625"-18 Internal Thread with Counterbore	615319

■ When adapting a 3-jaw chuck to .5625-18 internal thread spindle, order Chuck Adapter (623643) for .375" cap, chuck OR Chuck Adapter (619400) for .5" cap. chuck.

■ Fluid Swivels used with oil hole spindles and selection of Fluid Chucks (see page 2-23).

■ Other Noses and Spindles are available on request (see page 2-24).

■ Nose Indexers  
1.5625 -20 (381326)  
2.25 -20 (381327) Use with 615705 nose adapter.

## QUACKENBUSH™

### 230QGDA-RAC-SU-MS Series

**Capacity:**

Aluminum – 1.375" (34.9mm)  
 Titanium – 1" (25.4mm)  
 Steel – 1" (25.4mm)

**Stroke:**

Min. – .125" (3.18mm)  
 Max. – Unlimited

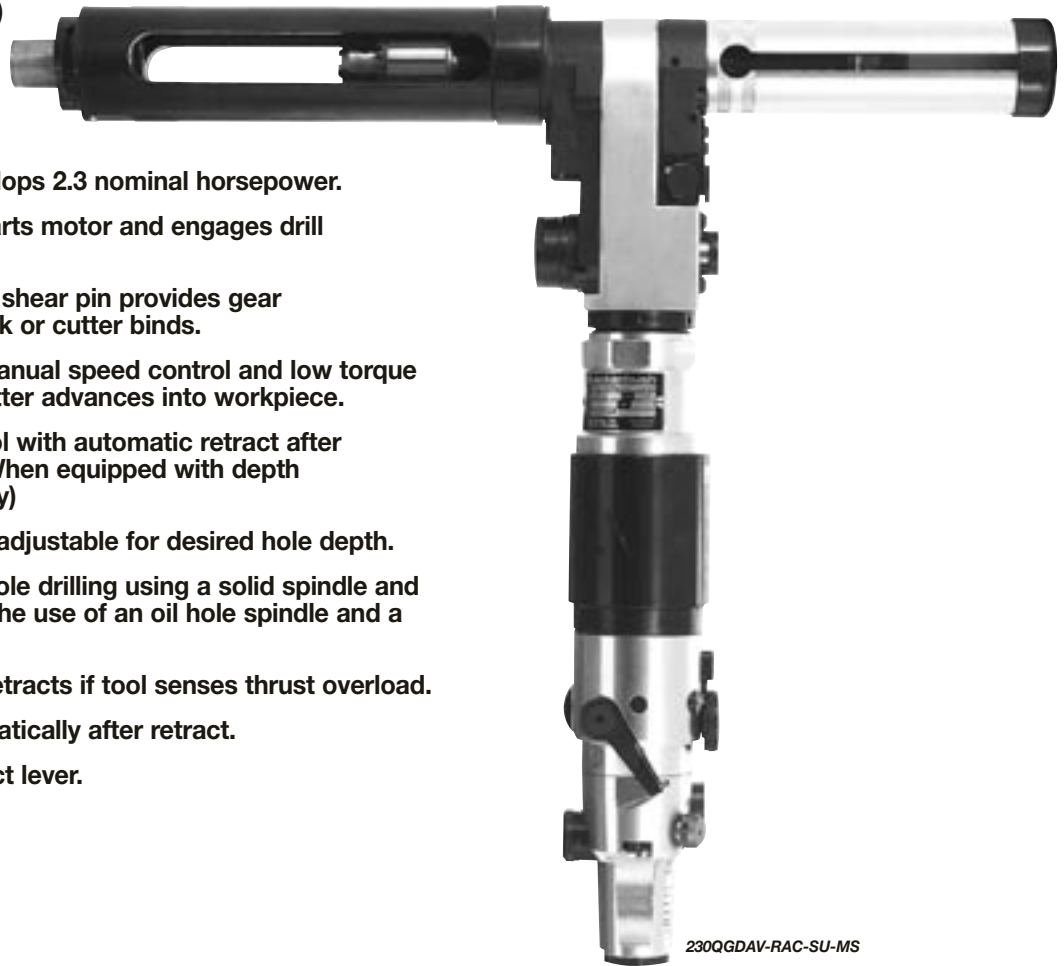

230QGDAV-RAC-SU-MS

- 230 series motor develops 2.3 nominal horsepower.
- Single push-button starts motor and engages drill feed mechanism.
- Externally replaceable shear pin provides gear protection if chips pack or cutter binds.
- Rapid advance with manual speed control and low torque clutch protection if cutter advances into workpiece.
- Precision depth control with automatic retract after preset dwell period. (When equipped with depth sensing nose assembly)
- Positive depth stop is adjustable for desired hole depth.
- Easily adapted to oil hole drilling using a solid spindle and a fluid chuck, or with the use of an oil hole spindle and a fluid swivel.
- Cutter automatically retracts if tool senses thrust overload.
- Motor shuts off automatically after retract.
- Auxiliary manual retract lever.

Model	Motor Configuration	Maximum Stroke		Weight*		Length*		Spindle Speeds	Feed Per Revolution	Inlet	Minimum Hose Size
		in.	mm	lbs	kg	in.	mm				
230QGDA-RAC-SU-MS	Right Angle	No Limit		17	7.7	20.75	527	50, 65, 80, 100, 125, 160, 205	.0005, .001, .002, .003, .0045, .006, .008, .012	.5" NPT	.5"
230QGDA-RAC-SU-MS	Right Angle	No Limit		15.75	7.1	18.75	476	260, 320, 390, 440, 550, 640, 770, 1100	.0005, .001, .002, .003, .0045, .006, .008, .012	.5" NPT	.5"
230QGDAV-RAC-SU-MS	Right Angle	No Limit		17.5	7.9	21.25	549	50/125 100/250	.0005, .001, .002, .003, .0045, .006, .008, .012	.5" NPT	.5"
230QGDAV-RAC-SU-MS	Right Angle	No Limit		16.25	7.4	19.25	489	210/520 420/1000	.0005, .001, .002, .003, .0045, .006, .008, .012	.5" NPT	.5"

\*Weight and Length will vary depending on Gear Train.

**NOTE:**

Tool model with either the 2.25"-20 L.H. External Nose Attachment Thread (Standard) or the 1.5625"-20 Internal Thread (Special) must be specified when ordering.  
 Rated tool performance at 90 PSIG measured at tool inlet with motor running.  
 When selecting speeds and feeds, see page I-5.

SEE PAGES I-11–I-13 FOR SAFETY PRECAUTIONS.  
 SEE PAGE 2-20 – 2-23 FOR TOOLING ACCESSORIES.

**WHEN ORDERING TOOL:**

Tool nose and spindle must be specified. Standard tool nose, spindle guard and spindle are provided at no charge when ordered with tool. Select one tool nose and one spindle. Specify EITHER 2.25"-20 External Thread OR 1.5625"-20 LH Internal Thread.

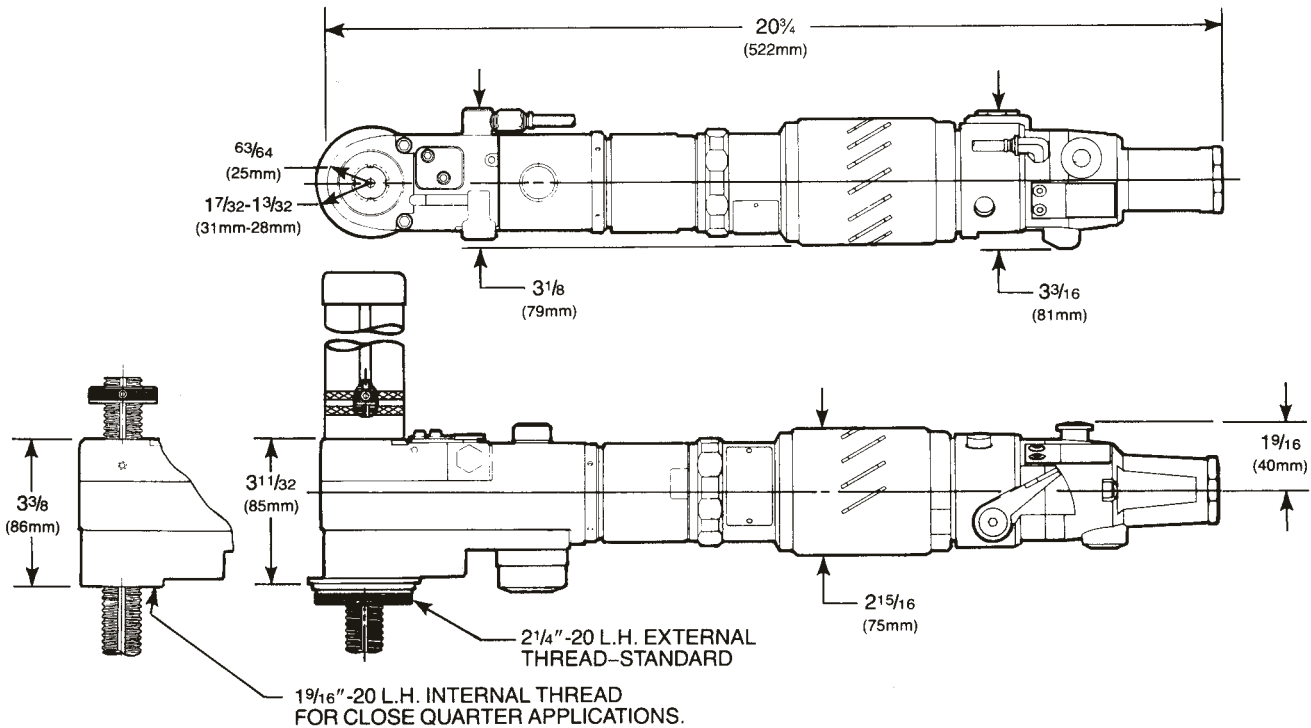

## STANDARD TOOL NOSE

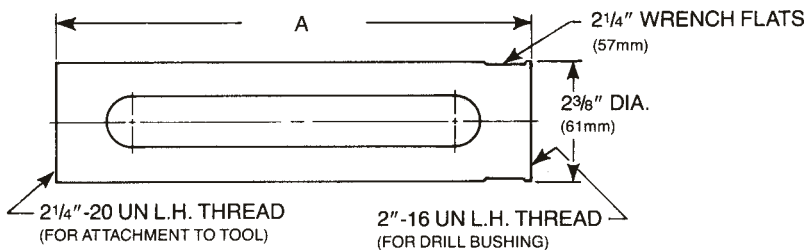

## STANDARD SPINDLE

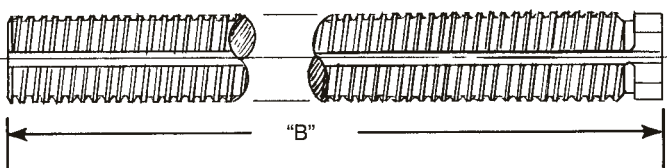

## STEEL TOOL NOSES (Select One)

Length "A"	Thread	Part No.
------------	--------	----------

### S400 SERIES

9.5" (241mm)	.75" - 16 L.H.	621235
9.5" (241mm)	1" - 14 L.H.	621236
9.5" (241mm)	1.25" - 12 L.H.	621237
9.5" (241mm)	1.5" - 12 L.H.	621238
9.375" (238mm)	2" - 16 L.H.	614751

### S600 SERIES

11.5" (282mm)	1" - 14 L.H.	621244
11.5" (282mm)	1.25" - 12 L.H.	621245
11.5" (282mm)	1.5" - 12 L.H.	621246
11.375" (279mm)	2" - 16 L.H.	614757

## SPINDLES (Select One)

Spindle Type	Length "B"	Max. Stroke	Thread Description	Part No.
Oil Hole	9" (229mm)	4" (103mm)	.5625"-18 Internal Thread with Counterbore and 118° Angle	382599
Oil Hole	9" (229mm)	4" (103mm)	.625"-24 Internal Thread with Counterbore and 118° Angle	382346
Solid	9" (229mm)	4" (103mm)	No. 2 Short Morse Taper with Side Knock-Out	382628

■ 2.25"-20 Nose Thread Attachment on standard tool accepts S400 and S600 Tool Noses and accessories.

■ For close quarter applications, a special tool with 1.5625"-20 L.H. Internal Nose Attachment Thread is available.

■ With the 1.5625"-20 L.H. Internal Thread, order Nose Adapter (614244) to attach S150 and S275 (2" O.D.) Tool Noses and accessories, OR Nose Adapter (614228) to attach S400 and S600 (2.375" O.D.) Tool Noses and accessories. (See page 2-24)

■ Nose Indexers - 1.5625"-20 (318326); 2.25"-20 (381327) for use with 615705 Nose Adapter.

■ When adapting a 3-jaw chuck to .5625 - 18 Internal Thread Spindle, order Chuck Adapter (623643) for .375" cap. chuck OR Chuck Adapter (619400) for .5" cap. chuck. (See page 2-22).

■ Fluid Swivels used with oil hole spindles and selection of Fluid Chucks. (See page 2-23)

■ Other Noses and Spindles are available at extra charge. (See page 2-24)

## QUACKENBUSH™

### 230QGDA-RAC-SU-MS Depth and Dwell Attachment

The Quackenbush Depth Control or Countersink Attachment is a high quality, precision attachment for the 230 Series Positive Feed Drill which is used to precisely control the depth of drilled and reamed, straight or tapered holes on both flat or contoured surfaces.

The attachment is also used for precision countersink operations. This attachment has been proven on the most demanding hole preparation jobs in the aircraft industry, and has earned the reputation for producing exceptionally high quality holes with precise depth accuracy, roundness and a high level of finish.

#### How the depth and dwell attachment operates

##### ■ Start

Threaded to the end of the Depth and Dwell Attachment is a DRILL BUSHING ③ which is used to secure the unit to the tooling fixture ②. A tubular SENSING SLEEVE ⑥ is piloted by and slides axially inside the DRILL BUSHING ③. The SENSING SLEEVE surrounds and pilots the CUTTER ⑦ and the SPINDLE ⑧. It is SPRING ④ biased to engage the WORKPIECE ① and seat against it ⑤. The primary function of the SENSING SLEEVE is to provide a positive, definite stopping surface that is a precise repeatable distance from the workpiece.

##### ■ Finish

Attached to SPINDLE ⑧ is a patented micrometer type, ADJUSTABLE ROTATING STOP ⑨ with a self-contained anti-friction bearing designed to engage the SENSING SLEEVE when the CUTTER has achieved the desired depth.

Once the pre-determined depth has been reached, the advancement of the CUTTER is stopped by the engagement of the ADJUSTABLE STOP on the SPINDLE contacting the SENSING SLEEVE. This allows the CUTTER to dwell (continue rotation without further feed) and produce the desired hole characteristics.

The Model 230 Right Angle Drill (furnished under separate order) features automatic thrust activated retract, torque overload shear pin, and automatic motor stop after retract.

When mounted on the Model 230 Right Angle Positive Feed Drill, the common SPINDLE ⑧ extends through and is driven by the right angle drill head.

Spindles (up to 15" long) will be hollow for coolant flow. A fluid inducer (Part No. 381213) may be purchased for the remote end of the spindle. Rear spindle guards must be used on all applications.

NOTE: Models designed for 1.186 maximum diameter cutters are common. Larger units for 1.750 maximum diameter cutters are available. Shortened models are available for short strokes in confined work areas.

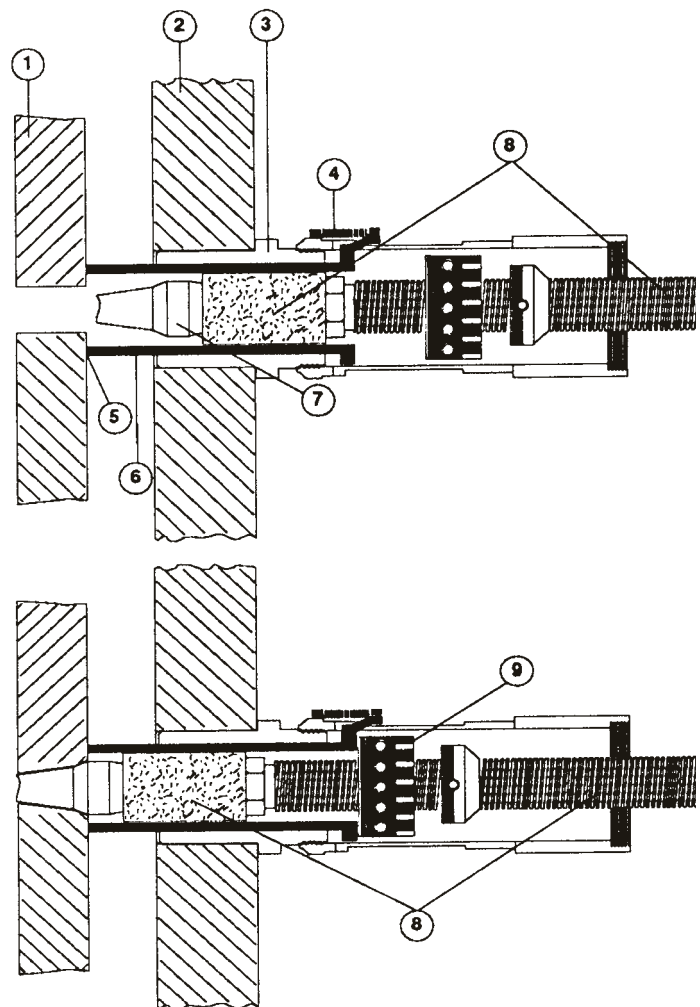

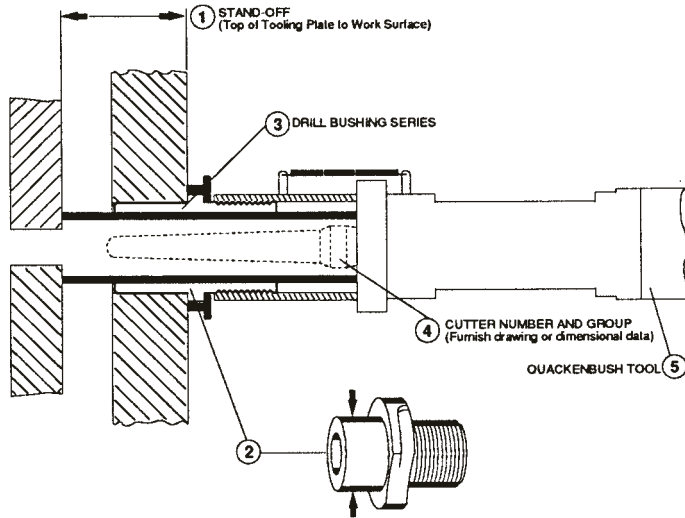

Depth and Dwell attachments are designed for each tooling application. The following information is required in order to obtain a quotation from the factory, Contact your local Quackenbush Specialist for assistance.

- ① Stand Off: \_\_\_\_\_ inches. (Minimum chip clearance .375")
- ② Drill Bushing Tip Outside Diameter: \_\_\_\_\_ inches.
- ③ Drill Bushing Series (Circle One):
- 2 Lock — 22,000, 23,00 & 24,000 Series
  - 3 Lock — 25,000, 26,000 Series
- ④ Cutter Information:
- Style (reference drawings at bottom of this page): \_\_\_\_\_
  - Furnish cutter Drawing or Dimensional Data (reference drawings at bottom of this page)
- A \_\_\_\_\_ F \_\_\_\_\_
- B \_\_\_\_\_ T \_\_\_\_\_ External Thread
- C \_\_\_\_\_ or \_\_\_\_\_
- D \_\_\_\_\_ T \_\_\_\_\_ Internal Thread
- E \_\_\_\_\_ Fluid Spindle: Yes \_\_\_ No \_\_\_
- ⑤ Nose Indexer: Yes \_\_\_ No \_\_\_
- ⑥ Quackenbush Tool Model No. \_\_\_\_\_

NOTE: • Important— If chip escape reliefs are required on the sensing sleeve, they must be specified when ordering. A drawing must be provided showing the exact location and type openings required.  
 • Some applications involving long cutters require that the tips of the cutter extend beyond the Dwell and Depth Attachment when the spindle is fully retracted.

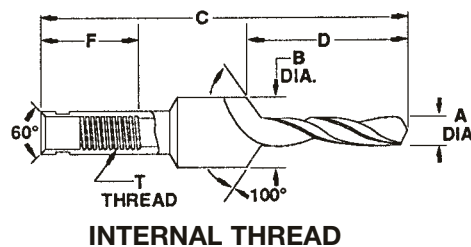
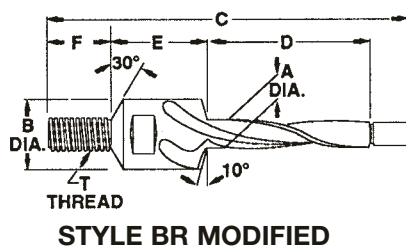
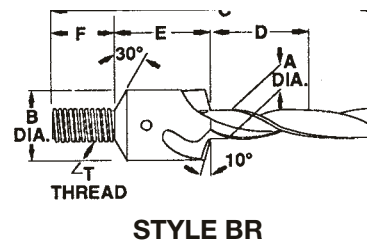
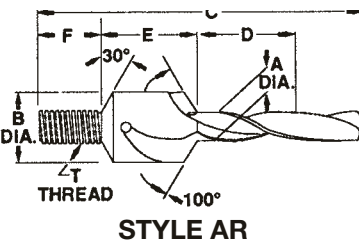
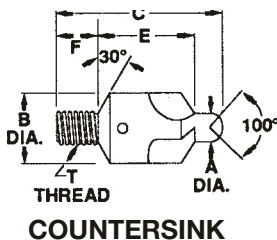

FOR OTHER CUTTER STYLES, FURNISH CUTTER DRAWING

## QUACKENBUSH™

### 230QGDA-RAD-GD Gun Drill Series

**Capacity:**

Aluminum – .75" (19.1mm)

**Stroke:**

Min. – .125" (3.2mm)

Max. – Unlimited

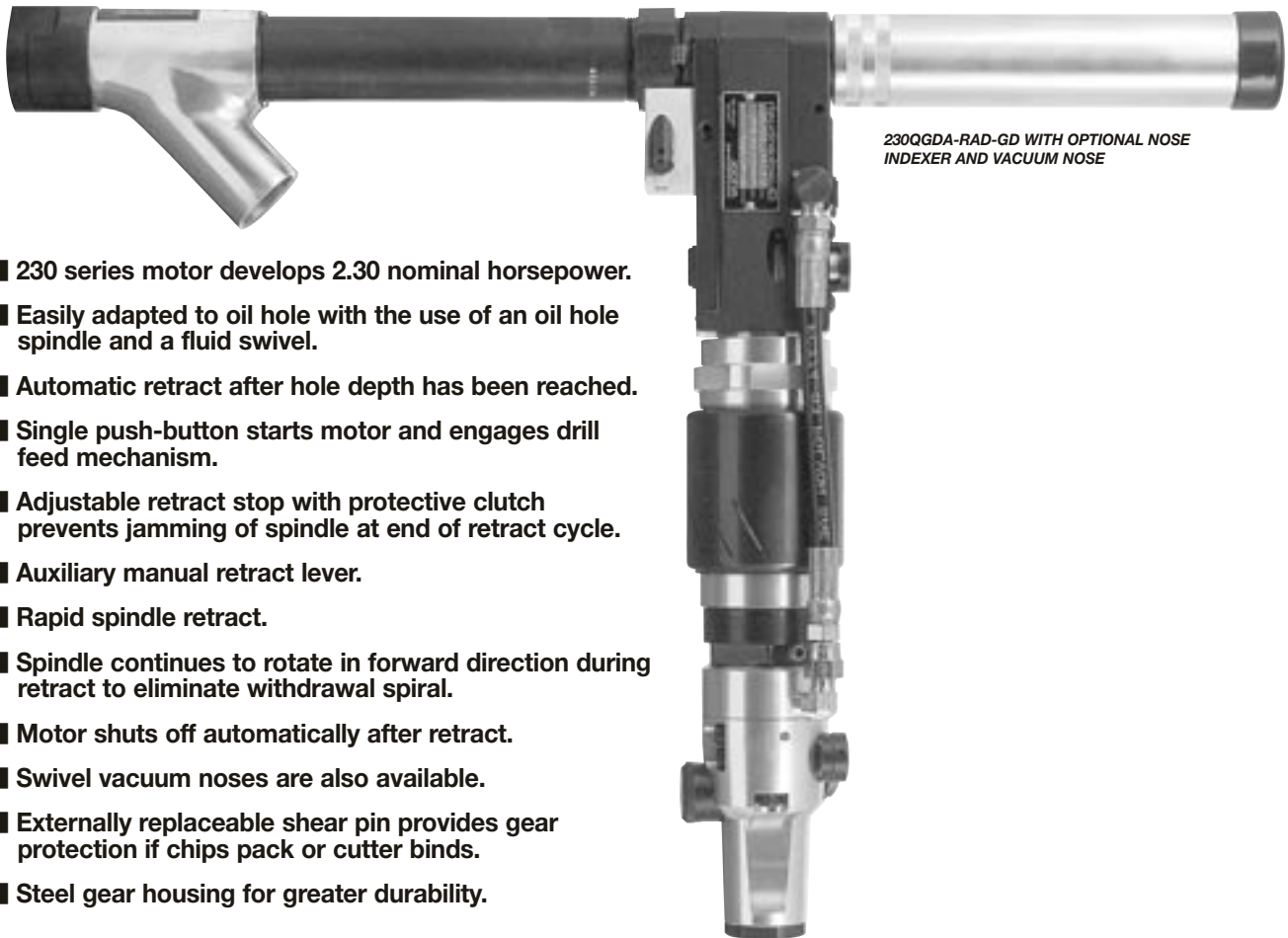

230QGDA-RAD-GD WITH OPTIONAL NOSE INDEXER AND VACUUM NOSE

- 230 series motor develops 2.30 nominal horsepower.
- Easily adapted to oil hole with the use of an oil hole spindle and a fluid swivel.
- Automatic retract after hole depth has been reached.
- Single push-button starts motor and engages drill feed mechanism.
- Adjustable retract stop with protective clutch prevents jamming of spindle at end of retract cycle.
- Auxiliary manual retract lever.
- Rapid spindle retract.
- Spindle continues to rotate in forward direction during retract to eliminate withdrawal spiral.
- Motor shuts off automatically after retract.
- Swivel vacuum noses are also available.
- Externally replaceable shear pin provides gear protection if chips pack or cutter binds.
- Steel gear housing for greater durability.

Model	Motor Configuration	Maximum Stroke		Weight*		Maximum Length		Spindle Speeds	Feed Per Revolution	Inlet	Minimum Hose Size
		in.	mm	lbs	kg	in.	mm				
230QGDA-RAD-GD	Right Angle	No Limit		13.25	5.95	15 7/8	403.23	1500, 1850, 2100	.0005, .001	.5" NPT	.5"

\*Weight is tool without spindle and nose piece.  
 Rated tool performance at 90 PSIG measured at tool inlet with motor running.  
 When selecting speeds and feeds, see page I-5.  
 Mist lubricator (631298) may be ordered.

SEE PAGES I-11-I-13 FOR SAFETY PRECAUTIONS.  
 SEE PAGE 2-20 – 2-23 FOR TOOLING ACCESSORIES.

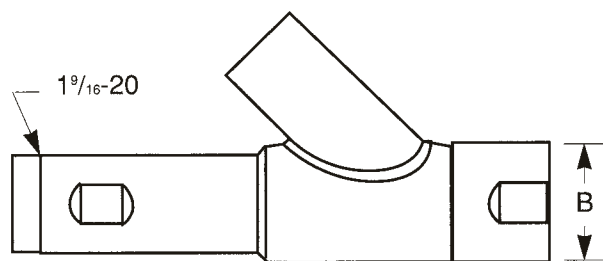
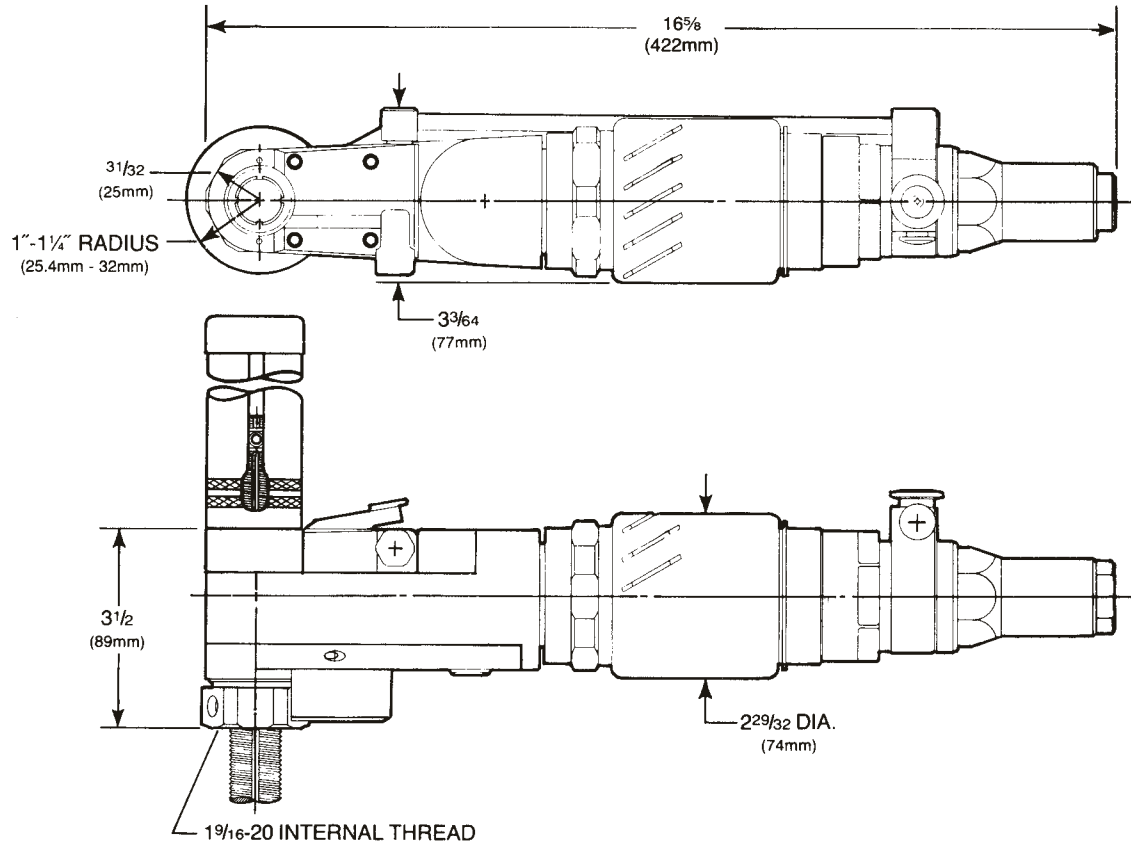

**STANDARD SPINDLE**

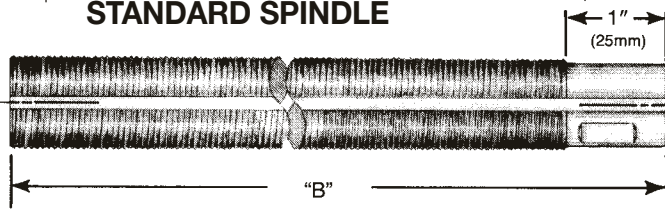

**SPINDLES (Select One)**

Spindle Type	Length "B"	Max. Stroke	Thread Description	Part No.
Oil Hole	9.25" (235mm)	4.5" (114mm)	.5625"-18 Internal Thread with Counterbore and 118° Angle	623955
Oil Hole	9.25" (235mm)	4.5" (114mm)	.625"-18 Internal Thread with Counterbore and 118° Angle	615964

Overall Length A	Part Number	Drill Bushing Thread Size B
7.50	631300	1.250-12 L.H.
8.50	631301	1.250-12 L.H.
9.50	631302	1.250-12 L.H.
11.50	631303	1.250-12 L.H.
7.50	631304	1.500-12 L.H.
8.50	631305	1.500-12 L.H.
9.50	631306	1.500-12 L.H.
11.50	631359	1.500-12 L.H.
11.50	631485	2.000-16 L.H.

- Nose Indexer - 1.5625"-20 (381326)
- Fluid Swivels used with oil hole spindles and selection of Fluid Chucks. (See page 2-23)
- Other Noses and Spindles are available at extra charge. (See page 2-24)



# Right Angle Tools Accessories

## Accessories for the No. 15 Series Right Angle Drill

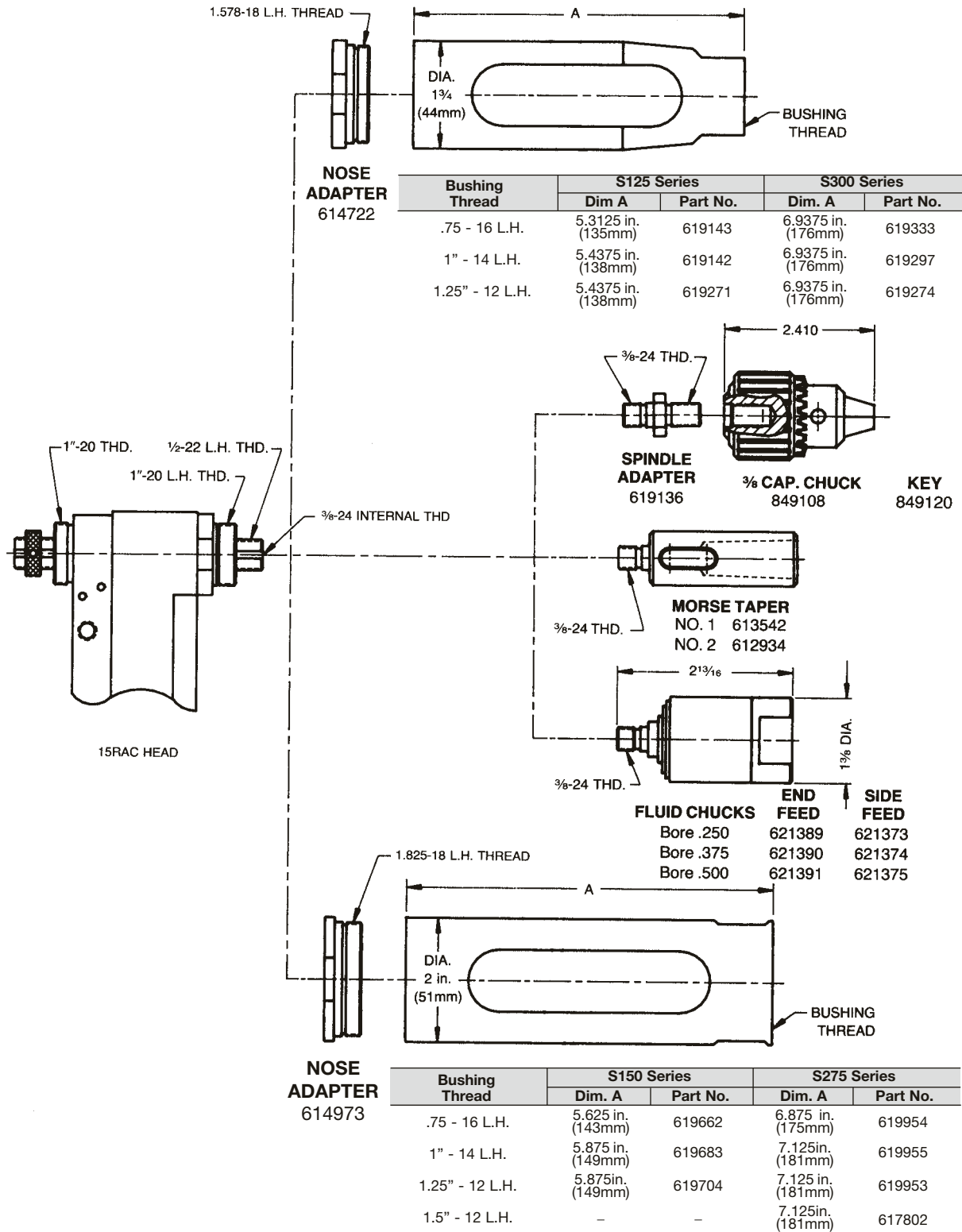

# Right Angle Tools Accessories

## Accessories for the No. 158 and 230GD Series Right Angle Drills

Bushing Thread	S150 Series		S275 Series	
	Dim. A	Part No.	Dim. A	Part No.
.75" - 16 L.H.	5.625 in. (143mm)	619662	6.875 in. (175mm)	619954
1" - 14 L.H.	5.875 in. (149mm)	619683	7.125 in. (181mm)	619955
1.25" - 12 L.H.	5.875 in. (149mm)	619704	7.125 in. (181mm)	619953
1.5" - 12 L.H.	-	-	7.125 in. (181mm)	615627

Fluid Chucks	END FEED		SIDE FEED	
	Bore	Part No.	Bore	Part No.
Bore .250	621389	621373		
Bore .375	621390	621374		
Bore .500	621391	621375		

Bushing Thread	S400 Series		S600 Series	
	Dim. A	Part No.	Dim. A	Part No.
1" - 14 L.H.	9.5 in. (241mm)	661236	11.5 in. (292mm)	621244
1.25" - 12 L.H.	9.5 in. (241mm)	621237	11.5 in. (292mm)	621245
1.5" - 12 L.H.	9.5 in. (241mm)	621238	11.5 in. (292mm)	621246
2" - 16 L.H.	9.375 in. (238mm)	614751	11.375 in. (289mm)	614757

Fluid Chucks	END FEED		SIDE FEED	
	Bore	Part No.	Bore	Part No.
Bore .500	621392	621376		
Bore .750	621393	621377		
Bore 1.000	621394	621378		

Bushing Thread	S700 Series	
	Dim. A	Part No.
1" - 14 L.H.	13.5625 in. (344mm)	621228
1.25" - 12 L.H.	13.5625 in. (344mm)	621229
1.5" - 12 L.H.	13.5625 in. (344mm)	621230
2" - 16 L.H.	13.4375 in. (341mm)	614749

# Right Angle Tools Accessories

## Accessories for the No. 230 B & RA Series Right Angle Drills

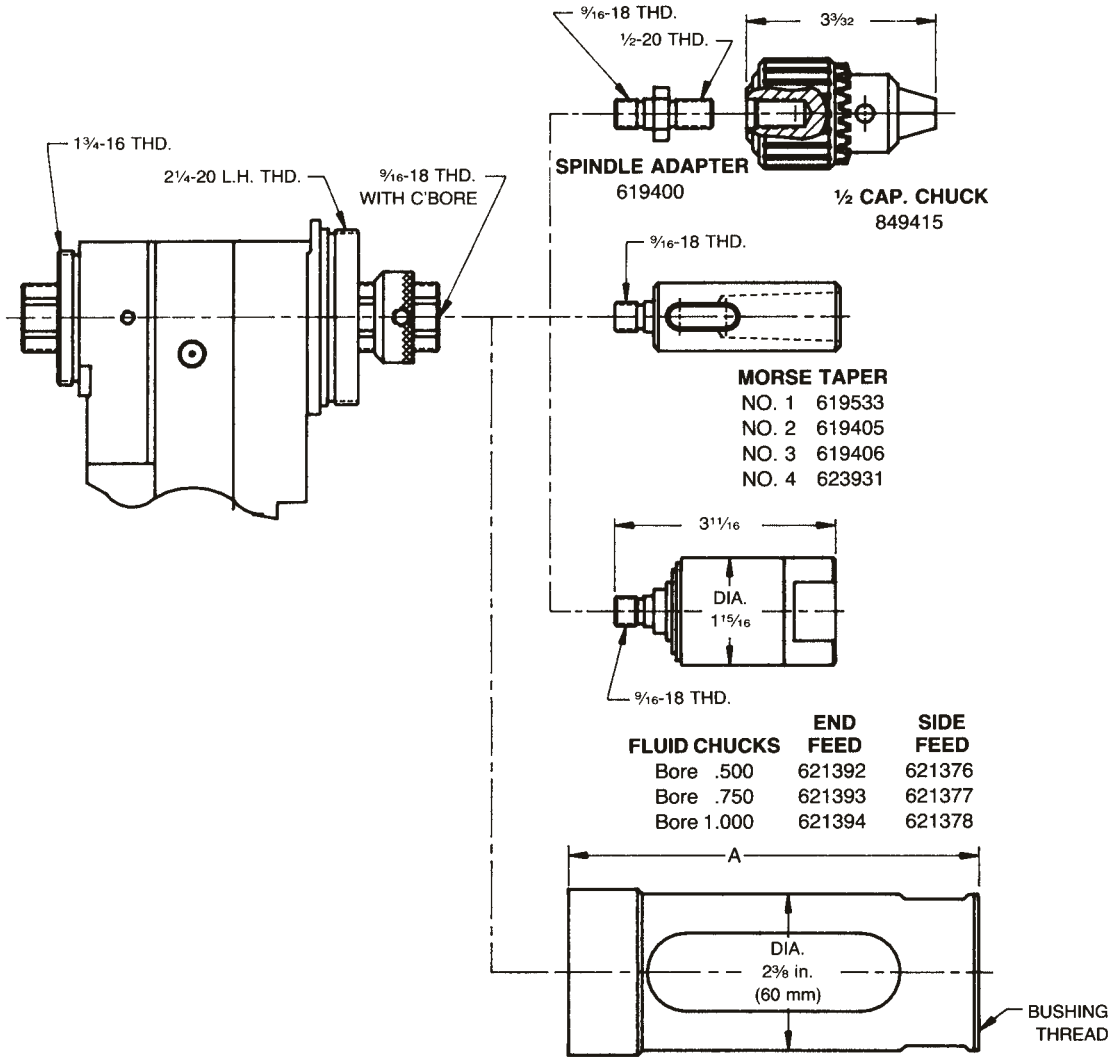

Bushing Thread	S400 Series		S600 Series	
	Dim. A	Part No.	Dim. A	Part No.
1" - 14 L.H.	9.5 in. (241mm)	661236	11.5 in. (292mm)	621244
1.25" - 12 L.H.	9.5 in. (241mm)	621237	11.5 in. (292mm)	621245
1.5" - 12 L.H.	9.5 in. (241mm)	621238	11.5 in. (292mm)	621246
2" - 16 L.H.	9.375 in. (238mm)	614751	11.375 in. (289mm)	614757

## Fluid Chucks

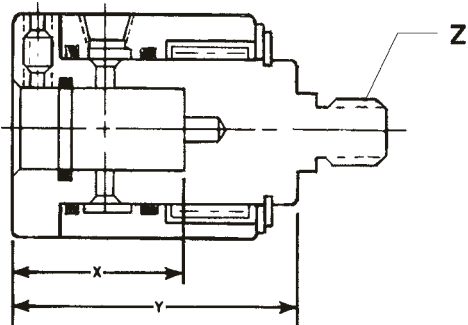

Side Feed

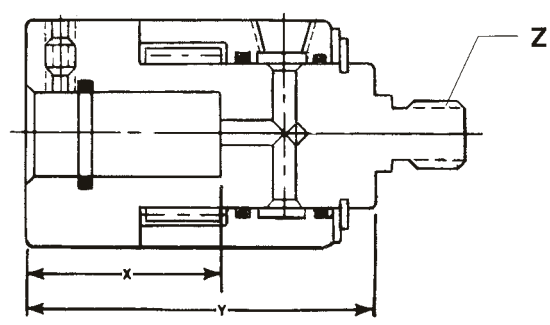

End Feed

Quackenbush Drill*	Bore Dia.	Side Feed			End Feed				
		Part No.	"X"	"Y"	"Z"	Part No.	"X"	"Y"	"Z"
S-125, S-300	250	621373	1.510	2.031	.375-24	621389	1.000	2.312	.375-24
S-265	.375	621374	1.510	2.031	.375-24	621390	1.000	2.312	.375-24
S-150, S-275	.500	621375	1.510	2.031	.375-24	621391	1.000	2.312	.375-24
S-400, S600	.500	621376	1.510	2.406	.5625-18	621392	1.437	3.000	.5625-18
S-400, S600	.750	621377	1.510	2.406	.5625-18	621393	1.687	3.000	.5625-18
S-400, S600	1.000	621378	1.510	2.406	.5625-18	621394	1.687	3.000	.5625-18
S-700, S750	1.000	621408	1.510	2.406	.75-16	621395	1.687	3.000	.75-16

\*Stroke length. Note: Dimensions X & Y are reference.

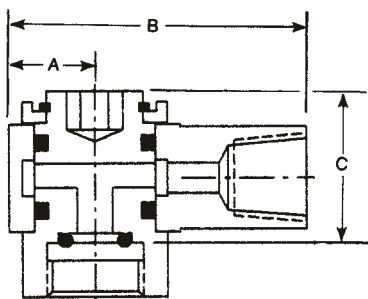

15 Series Swivel

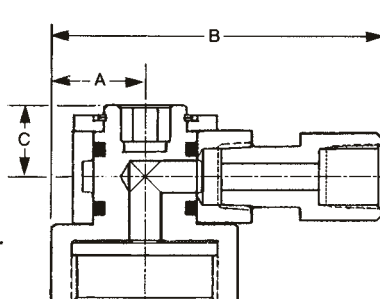

158 Series Swivel

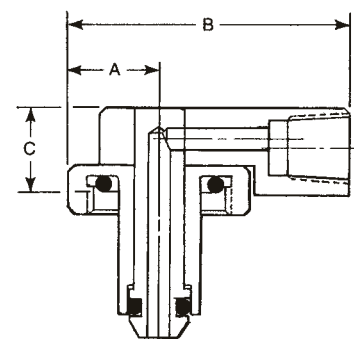

230 Series Swivel

Quackenbush Drill	Model	Part No.	A	B	C
15 QDA-RA-SU	ALL MODELS	631256	.4375	1.5	.7813
158QGDA-RA-SU	18 TPI SPINDLES	621448	.625	1.5	.8125
230QGDA-RA-SU-MS	12.5 TPI SPINDLES	381213	1.5625	1.75	.5

**NOTE:** Thread size for fluid line for all chucks and swivels is .125-27 NPT.

# Right Angle Tools Accessories

## How to order Spindles for Right Angle Tools

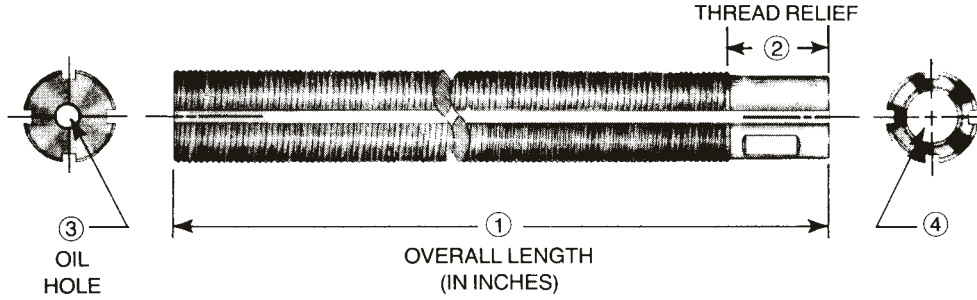

### INFORMATION REQUIRED TO ORDER SPINDLES:

① OVERALL LENGTH:

- Stroke \_\_\_\_\_ + 2.87" (73mm) for 15QDA-RA = \_\_\_\_\_ Overall Length
- Stroke \_\_\_\_\_ + 3.50" (89mm) for 140QGDA-RA-SU-MS = \_\_\_\_\_ Overall Length
- Stroke \_\_\_\_\_ + 3.75" (95mm) for 158QGDA-RA = \_\_\_\_\_ Overall Length
- Stroke \_\_\_\_\_ + 4.93" (125mm) for 230QGDA-RA-MS = \_\_\_\_\_ Overall Length
- Stroke \_\_\_\_\_ + 4.75" (121mm) for 230QGDA-RA-GD = \_\_\_\_\_ Overall Length
- Stroke \_\_\_\_\_ + 4.93" (125mm) for 230QGDA-MS = \_\_\_\_\_ Overall Length

② STANDARD SPINDLE THREAD RELIEF

- .875" for 15QDA-RA and 140QGDA-RA
- 1" for 158QDA-RA
- (.5625" flange width for 230QGDA-RA-MS)
- 1" for 230QDA-RA-GD

**NOTE:** Specify if Thread Relief is other than standard.

③ OIL HOLE REQUIRED?  Yes  No

**NOTE:** Spindle guards are highly recommended and are available for all spindles. Please specify when ordering.

④ END PREPARATION OF SPINDLE:

- INTERNAL THREAD:  
(Provide drawing specifying thread, depth, angle and counterbore depth if required)
- STRAIGHT BORE:  
Bore Diameter \_\_\_\_\_ inches  
Depth \_\_\_\_\_ inches
- INTERNAL MORSE TAPER (for 158 and 230 Models only)  
No. 1 Morse Taper   
No. 2 Morse Taper

## How to order Tool Noses for Right Angle Tools

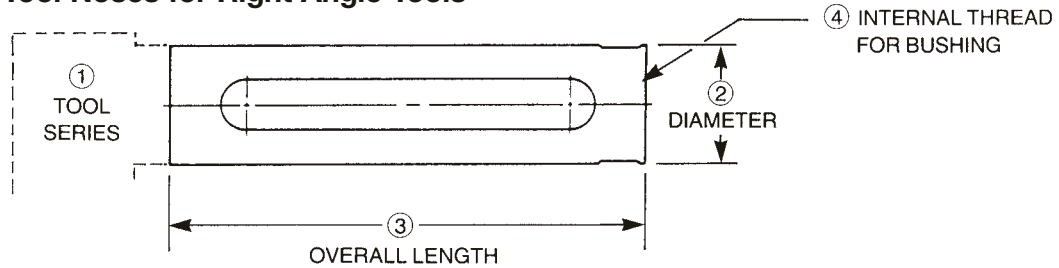

### INFORMATION REQUIRED TO ORDER TOOL NOSES:

① TOOL SERIES

- 15QDA-RA (1"-20 Nose Thread)
- 158QGDA-RA (1.5625"-20 OR 2.25"-20 Nose Thread)
- 230QGDA-RA-MS (1.5625"-20 OR 2.25"-20 Nose Thread)
- 230QGDA-RA-GD (1.5625"-20 OR 2.25"-20 Nose Thread)

② DIAMETER

- Standard Sizes - 1.1875" OD
- 15QDA-RA - 1.5625", 2" and 2.375" OD
- 230QGDA-RA-MS - 1.5625", 2" and 2.375" OD
- 230QGDA-RA-GD - 1.5625", 2" and 2.375" OD

③ OVERALL LENGTH

④ DRILL BUSHING SERIES

### DRILL BUSHING

BUSHING SERIES	QUACKENBUSH NOSE THREAD (ID)
21000	.75" - 16
22000	1" - 14
23000	1.25" - 12
24000	1.5" - 12
25000	2" - 16

Bushings are not furnished with Quackenbush Tools.

**NOTE:** Drawings for special tool noses must be provided when ordering.

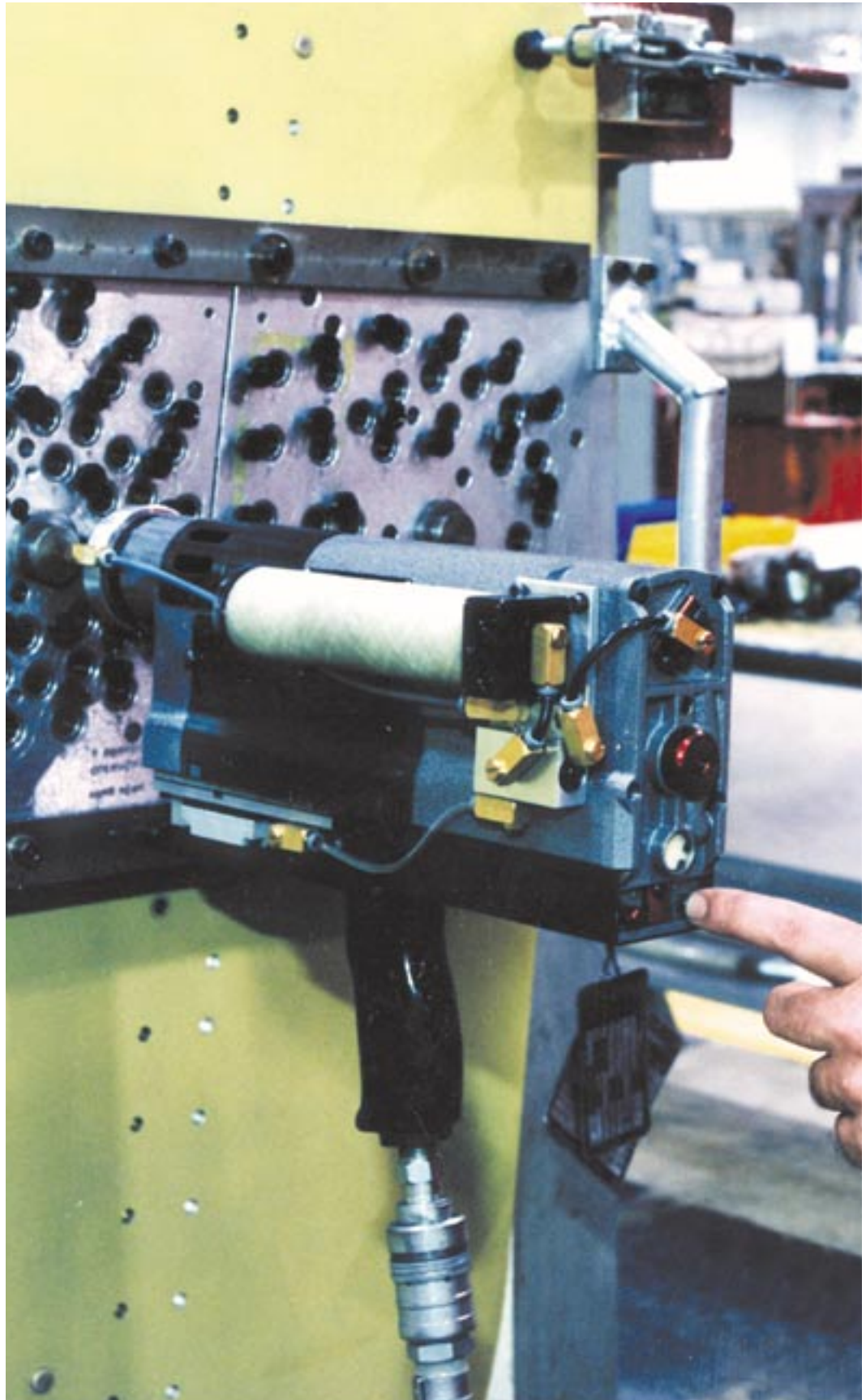

# Introduction

## Peck Feed Drills

Our peck feed drills are a unique category unto themselves. These drills drill a short distance, then retract from the hole to clear the chips and dissipate heat, and then return to the hole and drill again, and repeat this in-and-out motion until the process is finished. This pecking motion gives the drill its name.

This is a unique advantage in the drilling of deep close-tolerance holes, especially in stacks of dissimilar materials.

With conventional drilling, drilling through aluminum into materials such as titanium extracts chips of the titanium out of the hole, which scratches the softer aluminum and deteriorates the hole quality. But by using the interrupted stroke of the peck drill, the chips are smaller and are far less likely to create problems.

This also reduces heat considerably, because the drill is not in the hole continuously, building up heat. Each time the drill retracts from the hole, it helps to dissipate heat, significantly reducing distortion and metallurgical change in the material.

Because of their heat reduction capabilities, our peck drills have also been found to be highly productive in manufacturing environments that do not allow any type of lubrication or coolant.



### Equal Drill Time

Our HT Series Peck Feed Drills define state of the art in one shot, close tolerance hole drilling with portable tools.

During each peck, the peck timer circuit on competitive models combines the time to rapid advance, drill and retract. As you can see in the accompanying illustration, actual drill time is progressively reduced as the hole depth is

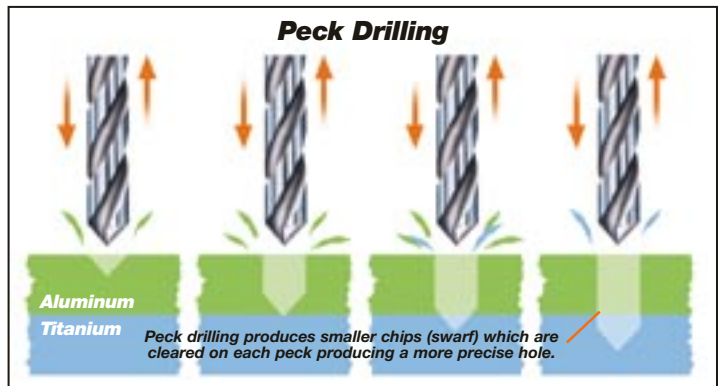
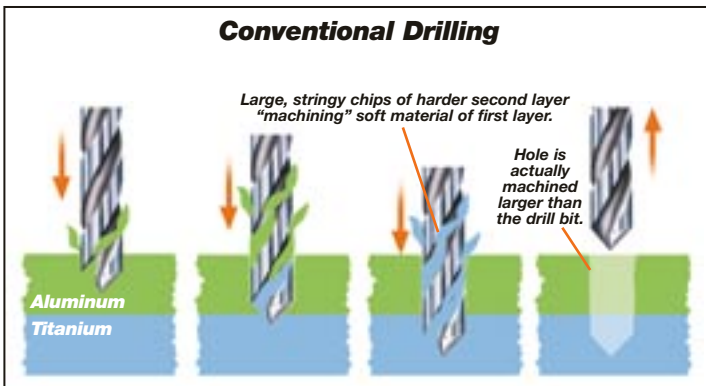

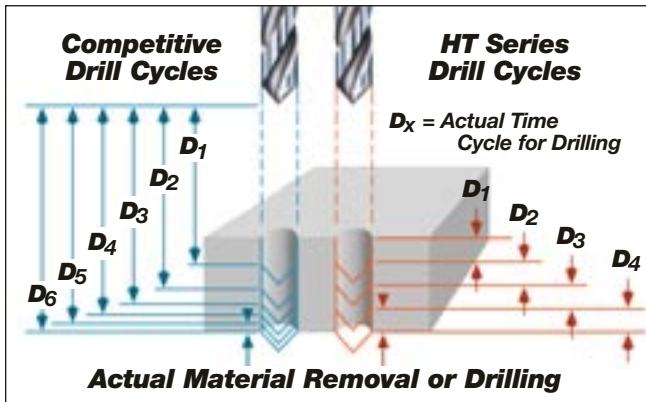

increased. With our HT Series drills, advancement and retraction times are separated from actual drill time, therefore the drill time is the same on each peck. The net result is increased performance.

## Drill Capacities

Peck drilling allows much larger diameter holes to be drilled than conventional drilling with respect to motor horsepower. Maximum diameter capacity will depend on drill chosen, material to be drilled, and cutter geometry. The adjoining chart shows capacities of our HT Series drills.

**Drill Capacities of the HT Series Peck Feed Drills**

Series	HP	Aluminum	Titanium	Steel
HT3	1.1	1.3	1.0	1.0
HT4	0.7	0.5	0.4	0.4

## HT Series Peck Feed Drill Performance Features & Benefits

### Adjustable Set Back

- Allows precise cutter point control while drilling.
- Improves hole quality.
- Prevents cutter breakage.
- Extends cutter life.

### Rapid Advance/Depth Controls

- Adjustable rapid advance to workpoint.
- Depth control adjustable to complete tool cycle at any point

### Interchangeable Motor Cartridges

- Quickly change RPM, HP, and spindle by exchanging a one-piece motor and gear cartridge.



### Start & Stop Buttons

- Easily accessible control buttons.
- Start button initiates automatic drilling cycle to preset depth-return and shut off.
- Stop button aborts drilling cycle at any point and returns drill to home position.

### Peck Control

- Lower knob allows automatic peck rate to be adjusted for optimum drilling conditions.
- Upper knob controls feed rate.
- Peck cycle can be turned off using set screw in logic plate, and tool will function as a conventional, fully automatic Airfeedrill.
- Tamper resistant, peck/dwell control cover included as standard equipment.

### Back Stop Adjustment

- Utilize any portion of drill stroke.

### Removable Pistol Grip Handle

- Makes the HT easier to carry.
- Makes relocation and lock-in fast & easy.



## QUACKENBUSH™

### HT3 Series

**Capacity:**

- Aluminum – 1.25"
- Titanium – 1"
- Steel – 1"

- 1.10 Horsepower
- Adjustable, controlled feed rate
- Adjustable peck rate, depth control, and rapid advance
- Equal Drill Time
- 4" Stroke
- One button start, fully automatic cycle
- Push button peck disable for non-peck advance at any time during the drilling cycle

- Reduces cost per hole
- Uses low cost cutters to produce high quality holes in dissimilar materials
- Eliminates most reaming operations
- Drills materials dry while maintaining acceptable hole quality and long cutter life.
- Remote start
- Rapid retract and re-entry minimizes cycle time
- Adjustable length nosepieces to fit cutter length
- Optional drill point lubricator to optimize hole quality



Model	Spindle	Speed Code	Function	Stroke
HT3	B – .5" - 20 Male Thread, Jacobs Chuck	120 – 12400 RPM	E - Equal Drill Time	40 - 4"
	C – .375" - 24 Female Thread	030 – 3000 RPM		
	D – .5625" - 18 Female Thread	021 – 2100 RPM		
	E – .75" - 16 Female Thread	016 – 1600 RPM		
		007 – 650 RPM		
		005 – 475 RPM		
		003 – 300 RPM		
		002 – 150 RPM		
	001 – 80 RPM			

<p><b>DRILL CAPACITIES:</b> Peck drilling allows much larger diameter holes to be drilled than conventional drilling with respect to motor horsepower. Maximum diameter capacity will depend on drill chosen, material, and cutter geometry.</p>	<p><b>SPECIFICATIONS:</b> Recommended Air Pressure: 90 PSIG Air Inlet Size: .375" N.P.T. Thrust @ 90 PSIG: 630 lbs. Weight: 18.6 lbs. (less nosepiece)</p> <p><b>STANDARD EQUIPMENT</b> Removable dead handle Hydraulic feed control Adjustable set-back control</p>	<p><b>EXTRA COST ACCESSORIES</b> (See pages 3-8 – 3-12) Fluid inducer Nosepieces (Fixed or Adjustable) Drill Point Lubricator Morse taper adapters Dwell Kit Concentric collet attachment</p>
--	--	---

## HT3 Series Dimensional Data & Accessories

Refer to pages 12 and 13 for Taper-Lok fixturing  
 Refer to pages 3-8 thru 3-12 for HT3  
 Series accessories.

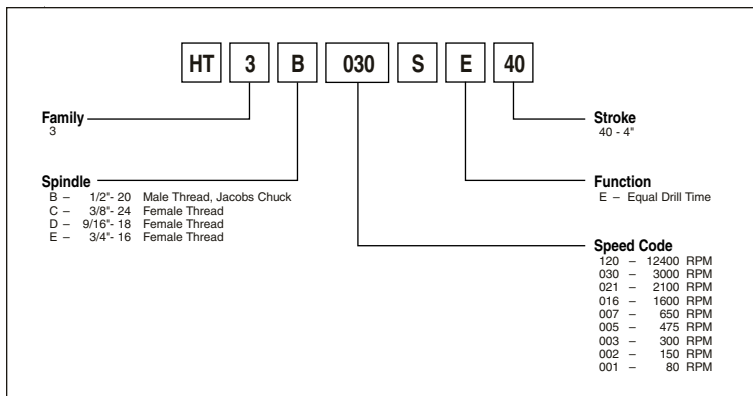
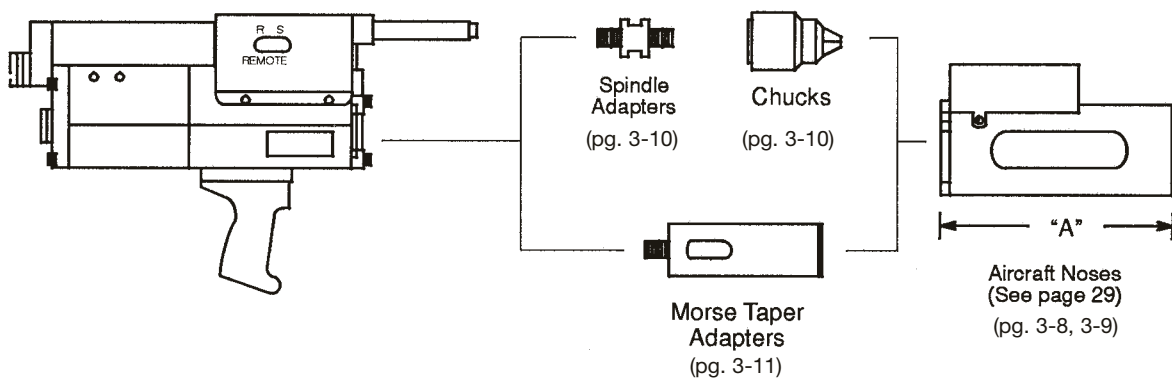
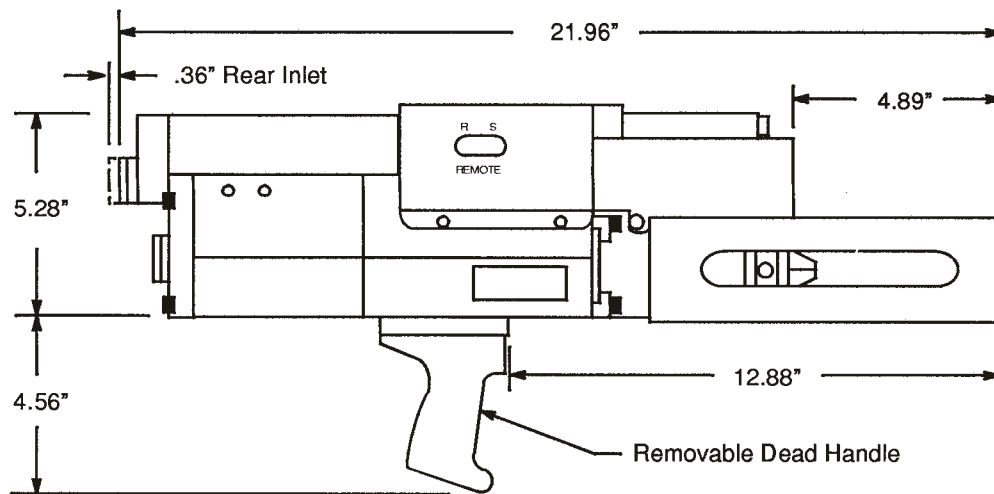

## QUACKENBUSH™

### HT4 Series

**Capacity:**

- Aluminum – .5”
- Titanium – .375”
- Steel – .375”

- .75 Horsepower
- Adjustable, controlled feed rate
- Adjustable peck rate and depth control
- Equal Drill Time
- 3” Stroke
- Integral nosepiece to reduce size and weight
- One button start, fully automatic cycle
- Reduces cost per hole
- Uses low cost cutters to produce high quality holes in dissimilar materials
- Eliminates most reaming operations
- Drills materials dry while maintaining acceptable hole quality and long cutter life.

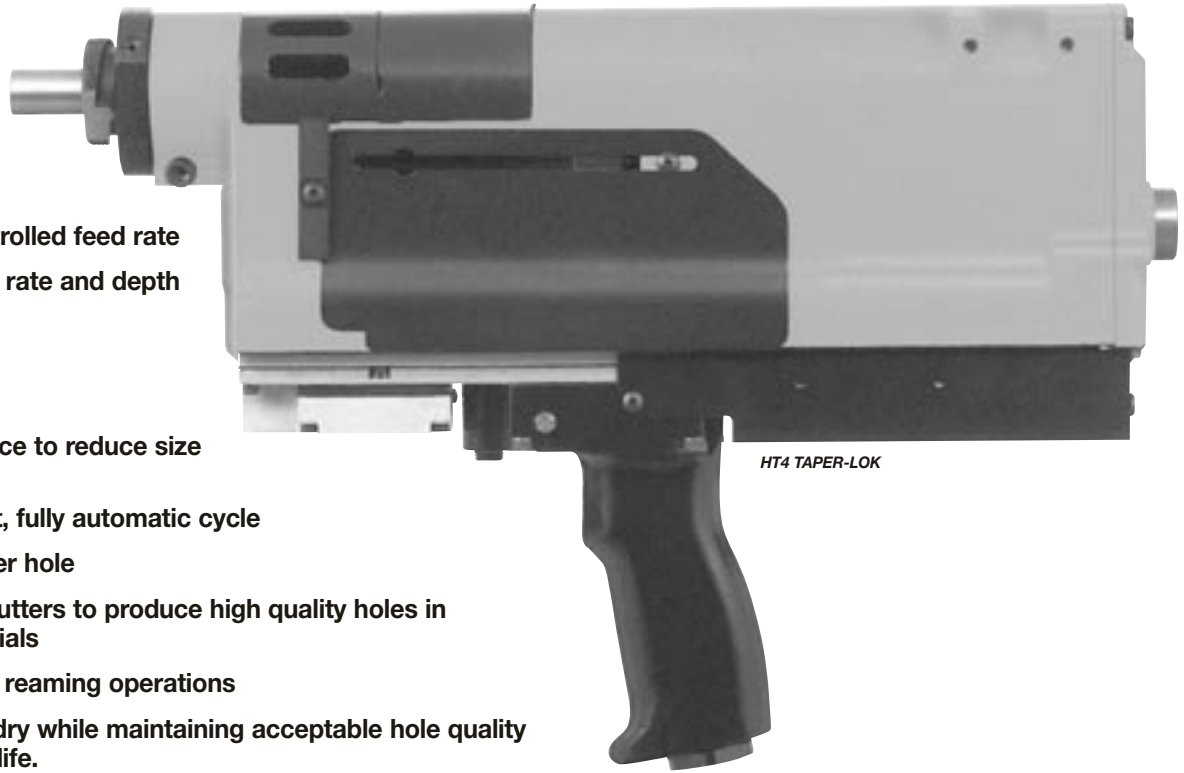

Model	Spindle	Speed Code	Function	Stroke	Mounting Adapter		Chuck	Handle
					Single/Dbl. Gear	Triple/Diff. Gear		
HT4	A - .375" - 24 Male Thread, T - #1 Jacobs Taper**	220 - 22000 RPM** 110 - 11000 RPM* 057 - 5700 RPM 029 - 2900 RPM 015 - 1500 RPM 008 - 780 RPM 005 - 500 RPM 003 - 270 RPM* 001 - 150 RPM*	E - Equal Drill Time	30 - 3"	A - 21000 Series B - 22000 Series C - 23000 Series D - 24000 Series	E - 21000 Series F - 22000 Series G - 23000 Series H - 24000 Series K - Concentric Collet‡	A - .375" Capacity B - 0-.25" Capacity #1 Jacobs Taper** X - No Chuck F - Fluid Inducing	N - None P - Pistol Grip

\* Triple or differential gearing

\*\* 22000 RPM tool must be ordered with spindle "T" and chuck "B". "T" Spindle available only with Speed Code 220.

**DRILL CAPACITIES:**

Peck drilling allows much larger diameter holes to be drilled than conventional drilling with respect to motor horsepower. Maximum diameter capacity will depend on drill chosen, material, and cutter geometry.

**SPECIFICATIONS:**

Recommended Air Pressure: 90 PSIG  
Air Inlet Size: .375" N.P.T.  
Thrust @ 90 PSIG: 500 lbs.  
Weight: 11.5 lbs.

**STANDARD EQUIPMENT**

Pistol Grip Handle  
Hydraulic feed control  
Adjustable set back control  
Tampor resistant covers  
Nosepiece with lubrication port

**NOTE:**

When ordering differential or triple geared models, to assure full 3" stroke, you must order proper mounting adapter. Two-inch stroke maximum will occur using standard adapter.

‡ Specify collet size and cutter diameter, See page 4-6

**EXTRA COST ACCESSORIES**

(See pages 3-8 - 3-12)  
Drill Point Lubricator  
Vacuum adapter  
Concentric Collet attachment

## HT4 Series Dimensional Data & Accessories

Refer to pages 14 and 15 for Concentric Collet details.

When Ordering, specify:

1. Complete model number from page 3-6.
2. Concentric Collet code number from chart on page 11.
3. Cutter guide diameter.

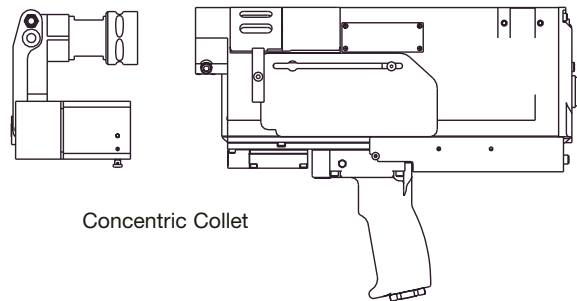
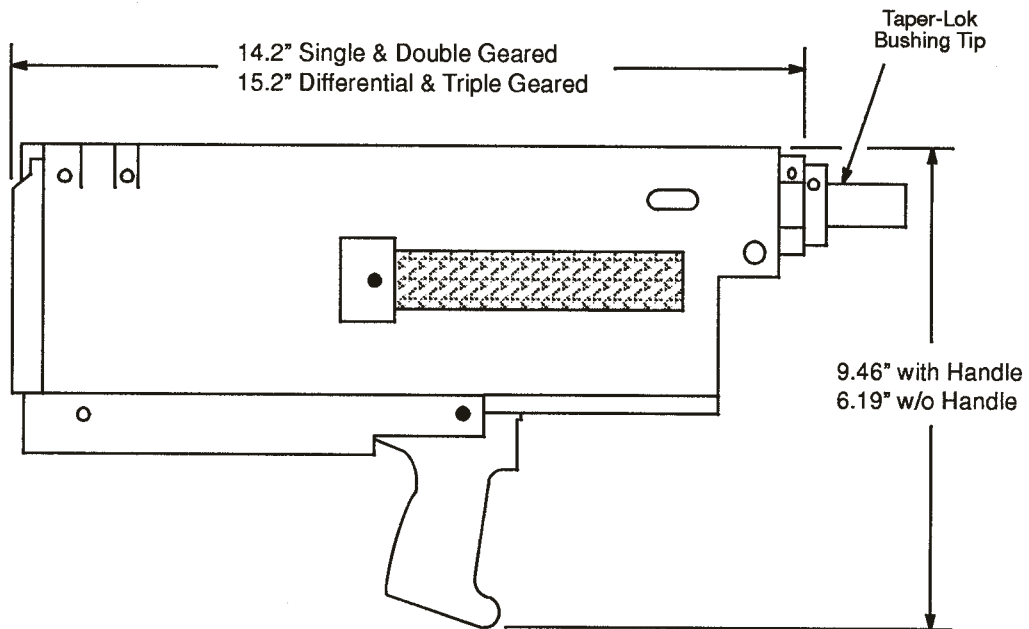

Concentric Collet

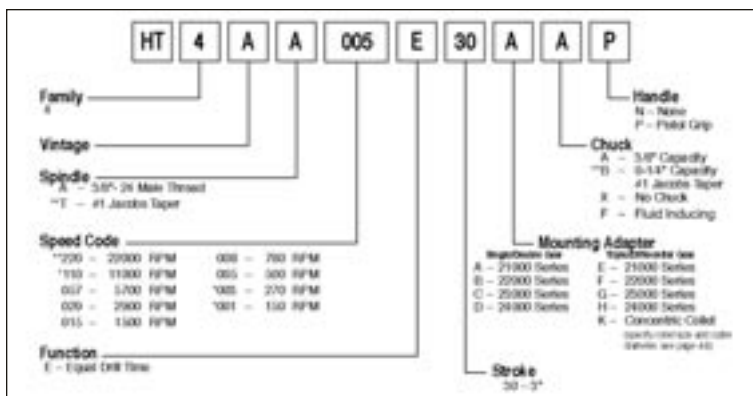

# Peck Drills Accessories

## Fixed Aircraft Nosepieces for HT1, HT2 and HT3

Nosepiece part number includes  
Guard and F571 (.125" NPT) Plug

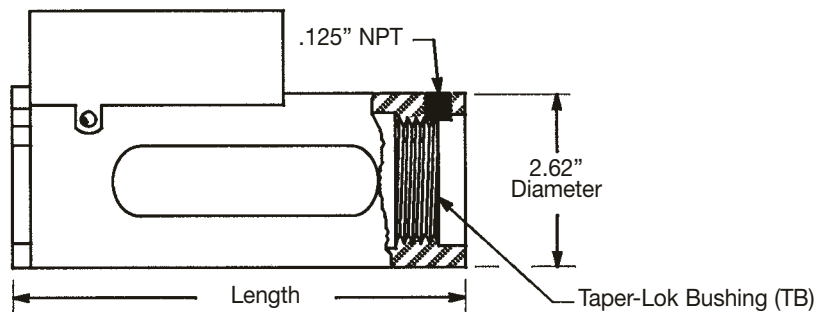

Part No.	Type	Stroke	Length	Guard	TB Series	Tool Mount
537259	Fluid Inducer (Alum.)	1.5"	6.97	537581	22000	HT2
537260	Fluid Inducer (Alum.)	1.5"	6.97	537581	23000	HT2
537261	Fluid Inducer (Alum.)	1.5"	6.97	537581	24000	HT2
537258	Fluid Inducer (Alum.)	1.5"	6.84	537581	25000	HT2
537131	Fluid Inducer (Alum.)	4"	10.16	537580	22000	HT1, HT3
537132	Fluid Inducer (Alum.)	4"	10.16	537580	23000	HT1, HT3
537133	Fluid Inducer (Alum.)	4"	10.16	537580	24000	HT1, HT3
537130	Fluid Inducer (Alum.)	4"	10.03	537580	25000	HT1, HT3
539522	Fluid Inducer (Steel)	1.5"	6.97	537581	22000	HT2
539523	Fluid Inducer (Steel)	1.5"	6.97	537581	23000	HT2
539524	Fluid Inducer (Steel)	1.5"	6.97	537581	24000	HT2
539525	Fluid Inducer (Steel)	1.5"	6.84	537581	25000	HT2
539622	Fluid Inducer (Steel)	4"	10.16	537580	22000	HT1, HT3
539623	Fluid Inducer (Steel)	4"	10.16	537580	23000	HT1, HT3
539624	Fluid Inducer (Steel)	4"	10.16	537580	24000	HT1, HT3
539625	Fluid Inducer (Steel)	4"	10.03	537580	25000	HT1, HT3

## Tapered Nosepieces

Nosepiece part number  
includes Guard

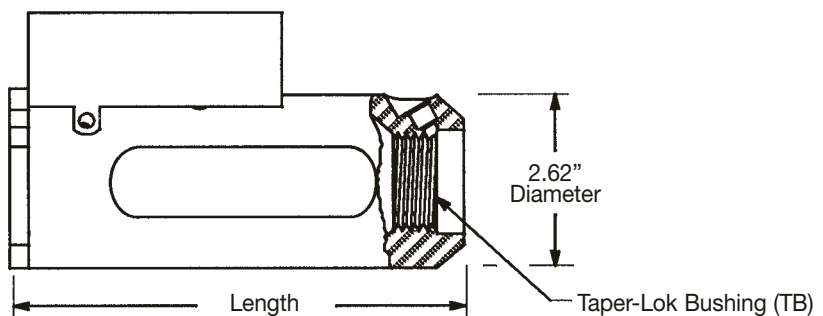

Part No.	Type	Stroke	Length	Guard	TB Series	Tool Mount
540240	Fluid Inducer (Alum.)	1.5"	6.84	537581	22000	HT2
540241	Fluid Inducer (Alum.)	1.5"	6.84	537581	23000	HT2
540242	Fluid Inducer (Alum.)	1.5"	6.84	537581	24000	HT2
540243	Fluid Inducer (Steel)	4"	10.03	537580	22000	HT1, HT3
540244	Fluid Inducer (Steel)	4"	10.03	537580	23000	HT1, HT3
540245	Fluid Inducer (Steel)	4"	10.03	537580	24000	HT1, HT3

## Adjustable Nosepieces for HT1, HT2 and HT3

Position of Bushing Tip can be precisely adjusted to drill length, eliminate drilling "Air".

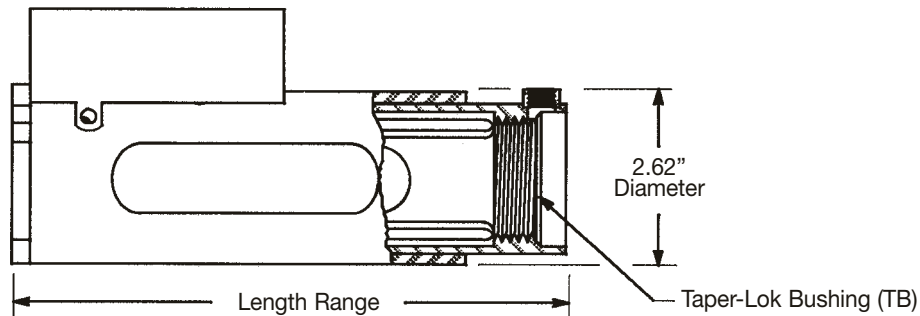

Part No.	Type	Stroke	Length Range	Guard	TB Series	Tool Mount
537373	Adjustable (Alum.)	3"	7.5 - 9.9	537581	22000	HT2
537374	Adjustable (Alum.)	3"	7.5 - 9.9	537581	23000	HT2
537375	Adjustable (Alum.)	3"	7.5 - 9.9	537581	24000	HT2
537376	Adjustable (Alum.)	3"	7.5 - 9.9	537581	25000	HT2
537134	Adjustable (Alum.)	4"	10.0 - 12.6	537580	22000	HT1, HT3
537135	Adjustable (Alum.)	4"	10.0 - 12.6	537580	23000	HT1, HT3
537136	Adjustable (Alum.)	4"	10.0 - 12.6	537580	24000	HT1, HT3
537142	Adjustable (Alum.)	4"	10.0 - 12.6	537580	25000	HT1, HT3
539007	Adjustable (Steel)	3"	7.5 - 9.8	537581	22000	HT2
539008	Adjustable (Steel)	3"	7.5 - 9.8	537581	23000	HT2
539009	Adjustable (Steel)	3"	7.5 - 9.8	537581	24000	HT2
539010	Adjustable (Steel)	3"	7.5 - 9.8	537581	25000	HT2
537583	Adjustable (Steel)	4"	10.0 - 12.4	537580	22000	HT1, HT3
537584	Adjustable (Steel)	4"	10.0 - 12.4	537580	23000	HT1, HT3
537585	Adjustable (Steel)	4"	10.0 - 12.4	537580	24000	HT1, HT3
537586	Adjustable (Steel)	4"	10.0 - 12.4	537580	25000	HT1, HT3

## Tapered Adjustable Nosepieces

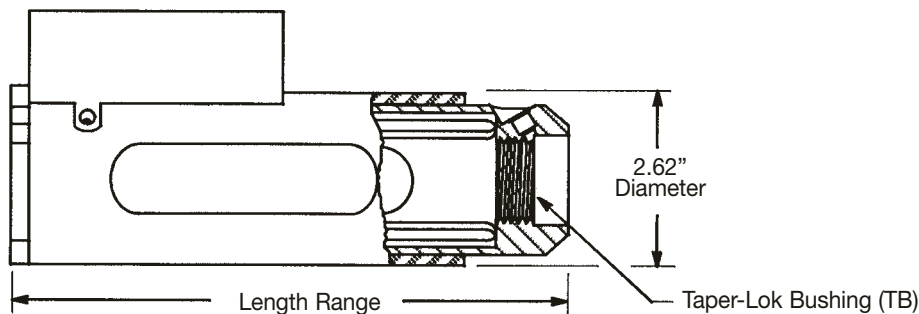

Part No.	Type	Stroke	Length Range	Guard	TB Series	Tool Mount
540246	Adjustable (Steel)	3"	7.5 - 9.8	537581	22000	HT2
540247	Adjustable (Steel)	3"	7.5 - 9.8	537581	23000	HT2
540248	Adjustable (Steel)	3"	7.5 - 9.8	537581	24000	HT2
540249	Adjustable (Steel)	4"	10.0 - 12.4	537580	22000	HT1, HT3
540250	Adjustable (Steel)	4"	10.0 - 12.4	537580	23000	HT1, HT3
540251	Adjustable (Steel)	4"	10.0 - 12.4	537580	24000	HT1, HT3

# Peck Drills Accessories

## HT3/HT4 Concentric Collet Attachment

Add to existing tool, order:

- P/N CC-HT13 (for colleting sizes to 1" - HT3)
- P/N CC-HT13M (for colleting sizes > 1" - HT3)
- P/N CC-HT4 (for colleting sizes to 1" - HT4)
- P/N CC-HT4M (for colleting sizes > 1" - HT4)

Specify:

1. Concentric Collet Code number (Chart on Page 4-6)
3. Cutter or Countersink Guide Diameter.

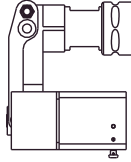

## FHT4 Inlet Manifold

P/N 1110897

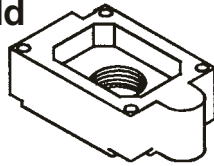

## Spindle Adapters

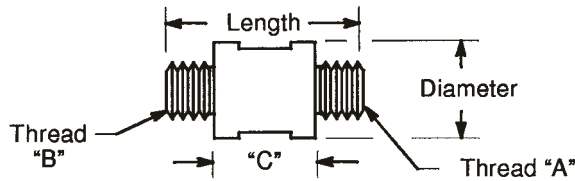

Part No.	Length	Dia.	"C"	Thd "A"	Thd "B"
1017808	2.15	.99	.99	.5625-18	.5-20
1018859	2.19	.62	1.43	.3125-24	.375-24
1018245	2.20	.99	.99	.375-24	.5625-18
1019072	2.92	1.12	.99	.7031-16	.375-16
1019506	1.44	.86	.25	.5-20	.5625-18
1110029	1.44	.86	.25	.375-24	.5625-18
1110112	1.87	.62	1.12	.375-24	.375-24
539011	1.14	.75	.25	.375-24	.5-20
539012	1.39	.88	.25	.5625-18	.5-20
539023	1.39	.75	.25	.375-24	.375-24

## Spindle Adapters

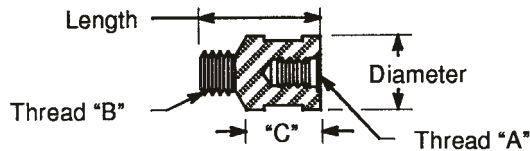

Part No.	Length	Dia.	"C"	Thd "A"	Thd "B"
1018243	1.37	.87	.84	.375-24	.5625-18

## Jacobs Chucks

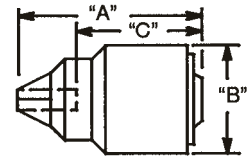

Part No.	Mount	Capacity	"A"	"B"	"C"
1005953	#OJT	.1563	1.09	0.85	0.59
1005078	.375"-24	.25	1.56	1.117	0.93
1001505	.375"-24	.25 HD	1.71	1.29	1.02
1004422	.375"-24	.375	2.16	1.67	1.09
1001252	.375"-24	.375	1.93	1.42	1.09
1009726	.375"-24	.5	2.42	1.79	1.28
1005398	.5"-20	.25	1.75	1.32	1.08
1005000	.5"-20	.375	1.93	1.42	1.13
1005020	.5"-20	.375	2.31	1.79	1.36
1000434	.5"-20	.5	2.42	1.79	1.28

## Chuck Assemblies

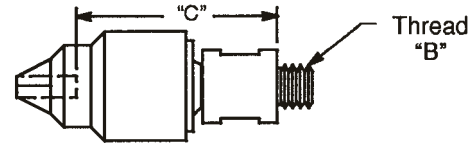

Assembly	Chuck	Adapter	"C"	Thd "B"
1025422	1001252	1018859	2.52	.3125-24
1025591	1001252	1110112	2.21	.375-24
1025427	1004422	1018245	2.08	.5625-18
1025473	1004422	1110029	1.34	.5625-18
1025301	1000434	1017808	2.27	.5-20
1025308	1000434	1019506	1.53	.5625-18

## Fluid Chucks

For using oil-hole drill bits.

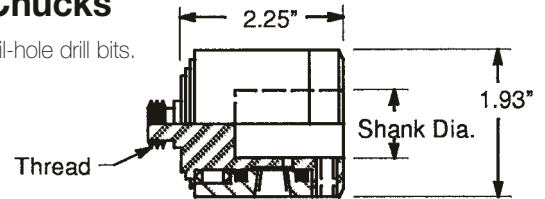

Part No.	Thread	Shank Dia.
1018219	.5625"-18	1.00
1018220	.5625"-18	0.75
1018221	.375"-24	0.50

## HT4 Mounting Adapters

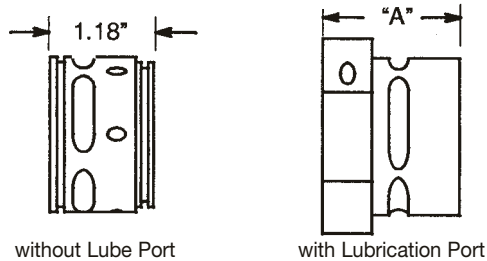

DBT Series	Part No.	Part No.	Dim "A"	Part No.	Dim "A"
21000	1110276	1110865	1.42"	1110450	2.06"
22000	1110277	1110866	1.42"	1110417	2.06"
23000	1110278	1110867	1.42"	1110451	2.06"
24000	1110279	1110868	1.42"	1110453	2.06"

## Morse Taper Adapter (Female Thd)

A Spindle Adapter is required to attach female thread Morse Taper Adapters to Buckeye Positive Feed Drills.

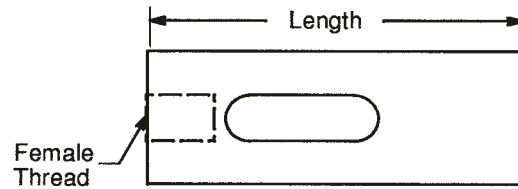

Part No.	Description	Thread	Length
529279	#1 Morse Taper	1/2"-20	3.69"
527989	#2 Morse Taper	1/2"-20	4.12"

## Reducer Bushings (for Taper-Lok)

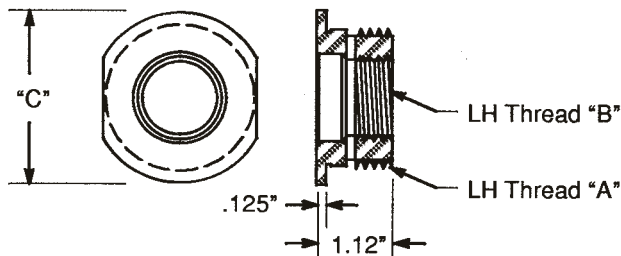

Part No.	"A"	"B"	"C"	TB	
				From	To
1110695	1"-14	.75"-16	1.38	22000	21000
1110700	1.5"-12	1.25"-12	1.94	24000	23000
1110699	1.5"-12	1"-14	1.93	24000	22000
1110696	1.25"-12	.75"-16	1.63	23000	21000
1110698	1.5"-12	.75"-16	1.94	24000	21000
1110697	1.25"-12	1"-14	1.63	23000	22000
1110701	2"-16	1.5"-12	2.50	25000	24000
537505	2"-16	1"-14	2.62	25000	22000
537506	2"-16	1.25"-12	2.62	25000	23000
537507	2"-16	1.5"-12	2.62	25000	24000

## Series 200 Collet Assemblies

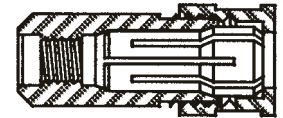

Part No.	Collet	Mounting Thd.
1025509	1/8"	3/8"-24
1025510	3/16"	3/8"-24
1025511	1/4"	3/8"-24
1025512	5/16"	3/8"-24
1025513	3/8"	3/8"-24

Note: Collet assembly includes specified collet.

## Morse Taper Adapter (Male Thd)

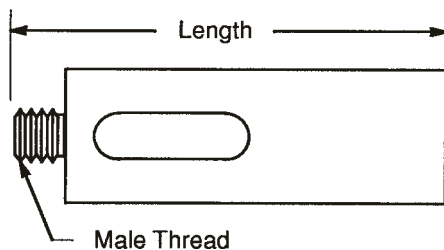

Part No.	Description	Thread	Length
1018117	#2 Morse Taper	.5625"-18	3.25"
1013853	#2 Morse Taper	.5625"-18	5.37"
1019070	#2 Morse Taper	.75"-16	5.50"
1013854	#3 Morse Taper	.5625"-18	5.93"
1019071	#3 Morse Taper	.75"-16	6.06"

## Series 200 Collets



Part No.	Size	
	inches	mm
204	.125"	3.175
46-500-141	.1406"	3.571
205	.1563"	3.962
46-500-172	.1719"	4.369
206	.1875"	4.762
46-500-203	.2031"	5.159
207	.2188"	5.563
46-500-234	.2344"	5.944
208	.25"	6.350
46-500-265	.2656"	6.731
209	.2813"	7.137
46-500-297	.2969"	7.544
210	.3125"	7.950
46-500-328	.3281"	8.331
211	.3438"	8.738
46-500-359	.3594"	9.119
212	.375"	9.525
46-500-390	.3906"	9.906

Add "C" to the part number for use with Thru-the-Spindle Coolant. Slots are filled with elastomer.



# Peck Drills Accessories

---

## Drill Point Lubricator

Utilizes PL-5 with special mounting bracket and shuttle valve.

Series	Fluid Oz. Capacity	Part Number
HT1/2/3	3.0	1026059
HT1/2/3	5.0	1026034
HT4	3.0	1026033
HT4	5.0	1026058

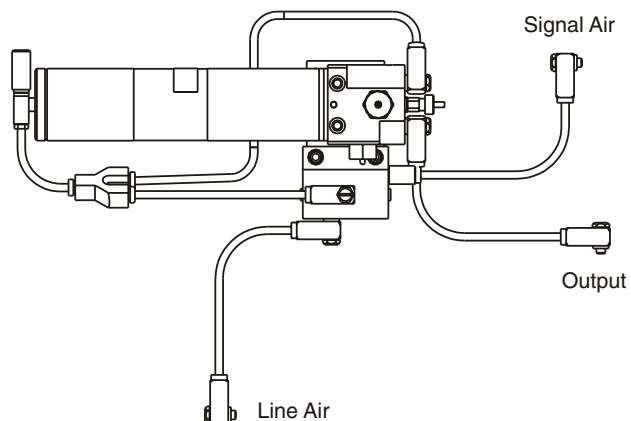

## Dwell Kit: 1025833 - HT1, HT2, & HT3 Series

Provides adjustable time at end of drilling stroke before automatic retraction.

## HT4 Series Vacuum Pickup Attachment: 1025928

Remove chuck cover and mount over "window". Has a port for 1.45" I.D. tubing.

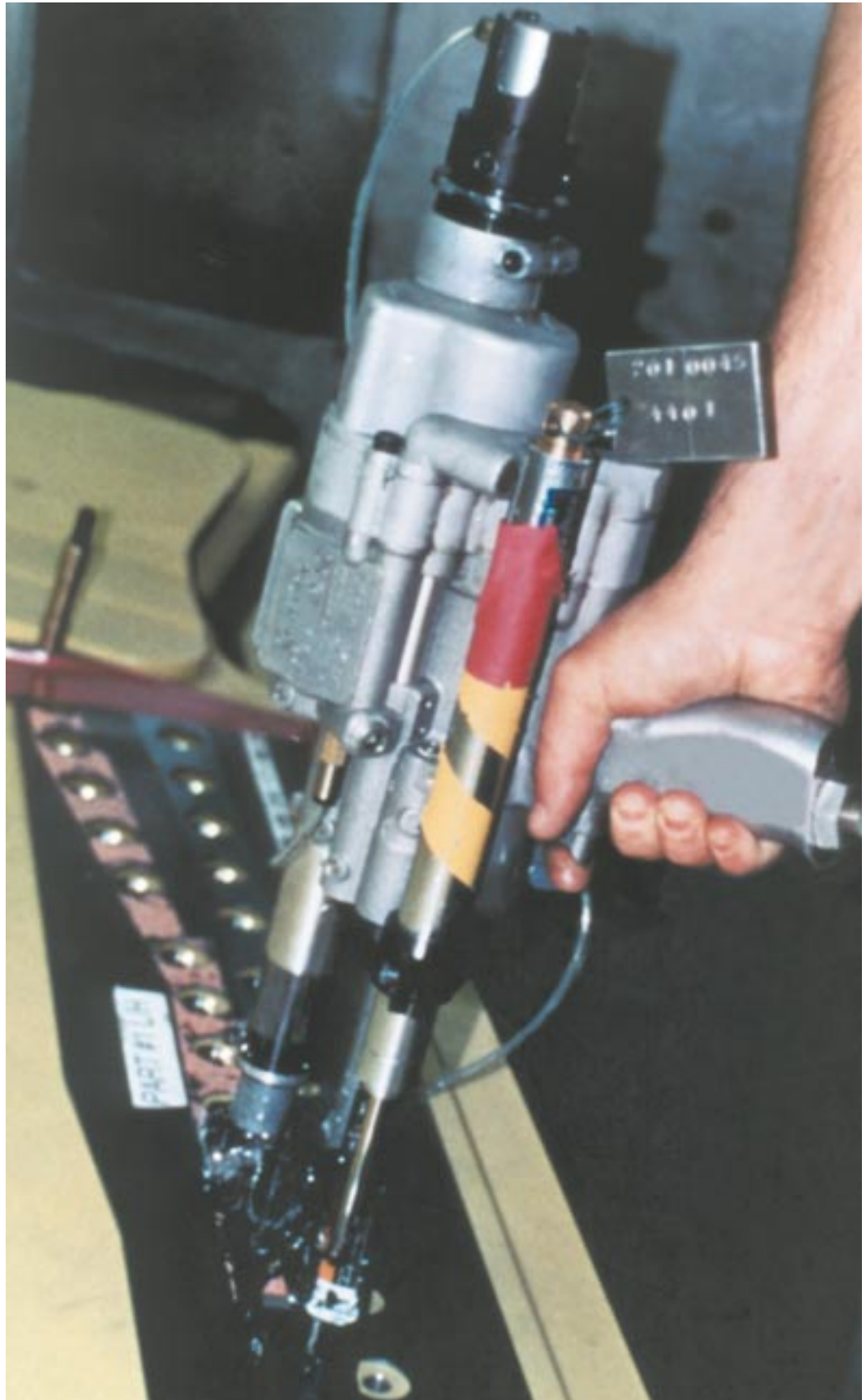

# Introduction

## Self Collecting Tools

Our self collecting drills provide rapid cycle times while producing quality holes and accurate countersinks. With stroke capacity from 1 inch to 3 inches, power capacity from 0.85 hp to 2.0 hp, and a full range of speeds, these self collecting tools are ideal for drilling and countersinking aircraft skin. Aluminum, laminates, and mixed stacks of aluminum or laminate over titanium or steel are well suited to the superb hole making capacity of these machines.

and simplifies the fixturing required to mount and locate these tools.

In the case of the variable spacing foot (also known as the template foot), the collet/mandrel is inserted into a predetermined hole in the workpiece. The template

### Operation

1. Position and clamp the drilling template on the workpiece.
2. Drill the first hole by conventional means.
3. Insert the Collet into the first hole and locate the Template Boss in the drilling template. Insure that the Collet/Mandrell extends through the workpiece.

4. Depress the trigger. Immediately, the Mandrel is drawn back and the Collet locks the tool to the work. Simultaneously, the motor starts and the tool feeds forward to a positive stop. The tool then retracts automatically and returns to its starting position.
5. Release the trigger; the motor shuts off and unclamping occurs.
6. Reposition the Boss and drill other holes within the colletting Range.
7. Withdraw the Collet/Mandrell and insert into a recently drilled hole. Repeat steps 3 through 6.

The drill/countersink cycle is automated, maximizing productivity with single trigger control. Each of these tools uses a variation of an expanding collet to clamp or fixture in a tooling plate or to clamp directly to the workpiece. This economizes

boss is inserted into a template hole with the boss face on the workpiece. When the trigger is actuated,

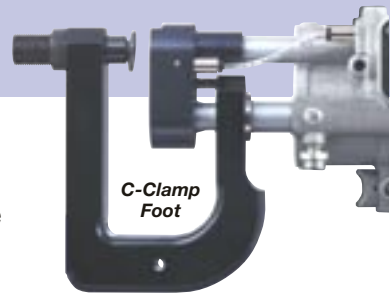

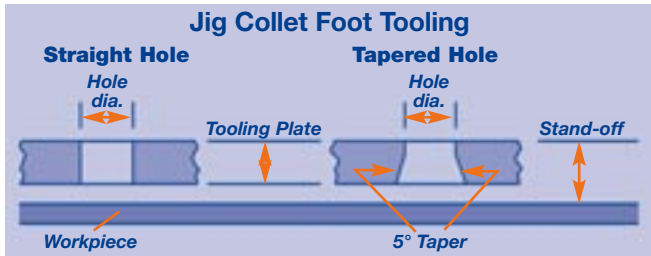

the tool first clamps by expanding the collet on the mandrel. The tool automatically feeds to a preset depth, and then automatically retracts. After retracting, the tool unclamps. Remaining in the same clamping location, the tool can then be moved to the next clamp location and the process repeated.



In the case of the jig collet and concentric collet, the expanding collet is co-axial with the tool spindle. The tool feeds to a preset depth, then automatically

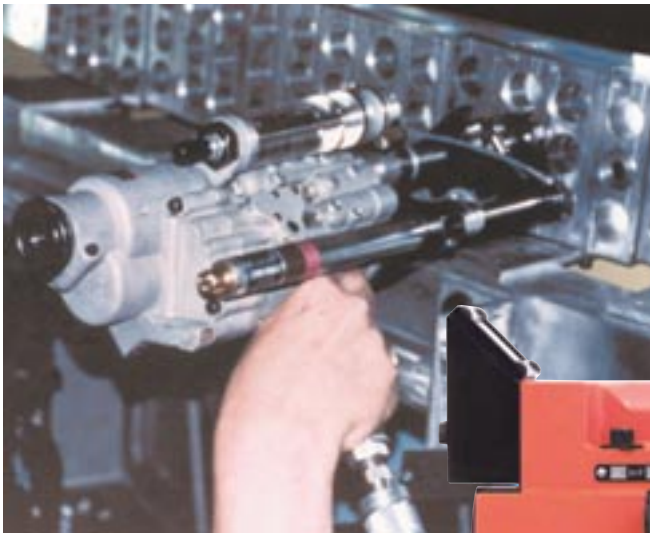

retracts. After retracting, the tool unclamps. The tool is then moved to the next location and the process is repeated.

In addition to the variable spacing foot, concentric collet, and jig collet foot, the C-clamp configuration is also available. This configuration is ideal for applications near the edge of surfaces.

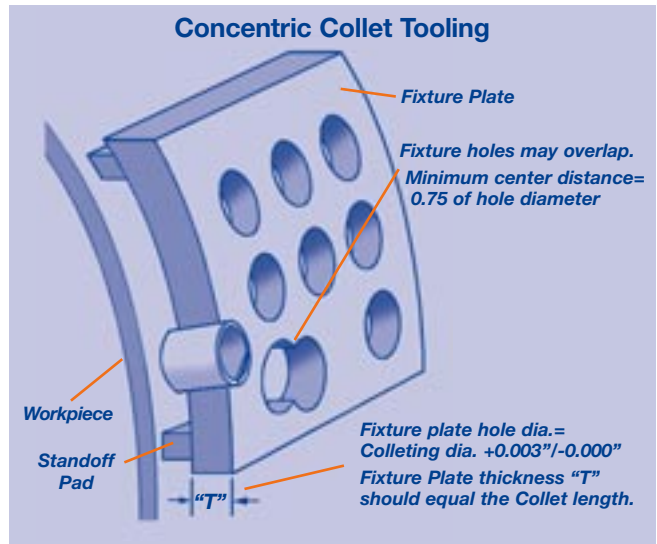
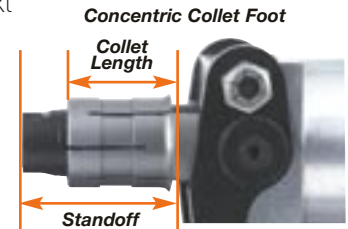

## DOLER®

### P2 Drill with Variable Spacing Foot

- Light and compact - yet rigid and rugged
- Modular design - for easy setup and servicing
- Variety of spindle speeds and terminations to satisfy a wide range of applications
- Collet/Mandrel slides easily - very smooth operation
- Micro Depth Adjustment - countersink depths within  $\pm .001$ "
- Infinitely adjustable feed rate
- 1.0 Horsepower motor
- Adjustable foot pad for vertical holes regardless of surface curvature
- Variable Spacing Foot can be oriented in any position. No need for separate left and right hand versions.
- Quick release collet/mandrel assembly
- Rotating cutter/countersink guide for maximum cutter life and hole quality



P2	V	A	S	1	C	X	X	2	187	C	X	
<b>TYPE</b>											<b>ACCESSORY CODE</b>	
V = Variable Spacing Foot											A = Drill Point Lubricator & Vacuum	
<b>VINTAGE</b>											L = Drill Point Lubricator	
A, B, C, etc.											M = Handling Ring	
<b>MOTOR/STROKE</b>											V = Vacuum adapter	
<b>SPINDLE SPEED</b>											X = None	
1 = 5200 RPM    5 = 1300 RPM    8 = 6000 RPM											<b>TEMPLATE BOSS (Dia. x Projection)</b>	
2 = 3200 RPM    6 = 800 RPM											A = .500 x .062    K = .625 x .200	
3 = 1900 RPM    7 = 500 RPM											B = .500 x .100    L = .625 x .250	
<b>SPINDLE TERMINATION</b>											C = .500 x .150    M = .625 x .300	
A = Erickson 200 Collet Chuck    E = .25-28 x 0.500											D = .500 x .175    N = .750 x .100	
C = "Drivematic" (Erickson 300)    "Spacematic"											E = .500 x .200    O = .750 x .150	
D = .25-28 x 0.375 "Spacematic"    P = .375-24 Piloted External Thread											F = .500 x .250    P = .750 x .175	
Note: Spindles D, E & P utilize 200 collet with spindle adapter.											G = .625 x .062    Q = .750 x .200	
<b>CUTTER COLLET (Dia. inches)</b>											H = .625 x .100    X = None	
200 Series (Spindle "A")											I = .625 x .150    Z = Prompt-Special Diameter	
A = .125    G = .219    M = .313											J = .625 x .175	
B = .141    H = .234    N = .328											<b>COLLET DIAMETER (clamping, pg 4-9, 4-10)</b>	
C = .156    I = .250    O = .343											116 140 172 203 234 265 297	
D = .172    J = .266    P = .359											120 145 177 208 239 271 302	
E = .188    K = .281    Q = .375											123 150 182 213 245 276 307	
F = .203    L = .297    R = .391											125 156 187 219 250 281 312	
Cutters longer than .391 should have shank reduced.											130 161 192 224 255 286	
Spindles D,E & P specify Q											135 166 197 229 260 291	
<b>CUTTER GUIDE (Dia. inches)</b>											<b>COLLET LENGTH (clamping, pg 4-8)</b>	
X = None (Spindle "C")    W = .500    Q = .375											1 = 0-0.10 Grip    3 = 0.2-0.56 Grip	
											2 = 0-0.30 Grip    4 = 0.5-0.81 Grip	

\*Note: Complete Check Sheet on page 4-00 before placing order.

**SPECIFICATIONS:**  
Power: 1.0 hp  
Air Consumption: 30 scfm

Air Inlet Size: 3/8 NPT  
Recommended Hose Size: 3/8" I.D.  
Thrust: 230 lbs. @ 90 psig  
Stroke (overall) 1"  
Length: 13.2"

Weight: 9.7 lbs.  
Hole Spacing Range: 0.74" to 3.0"  
(collecting hole to drilled hole)  
Collet/Mandrel Stroke: 0.50"-  
Material thickness variation

**EXTRA COST ACCESSORIES**  
Vacuum Pickup Adapter (pg. 4-8)  
Drill Point Lubricator (pg. 4-8)  
Handling Ring (pg. 4-9)

# Doler® Self Collecting Machines

## Dimensional Data - P2 Drill with Variable Spacing Foot

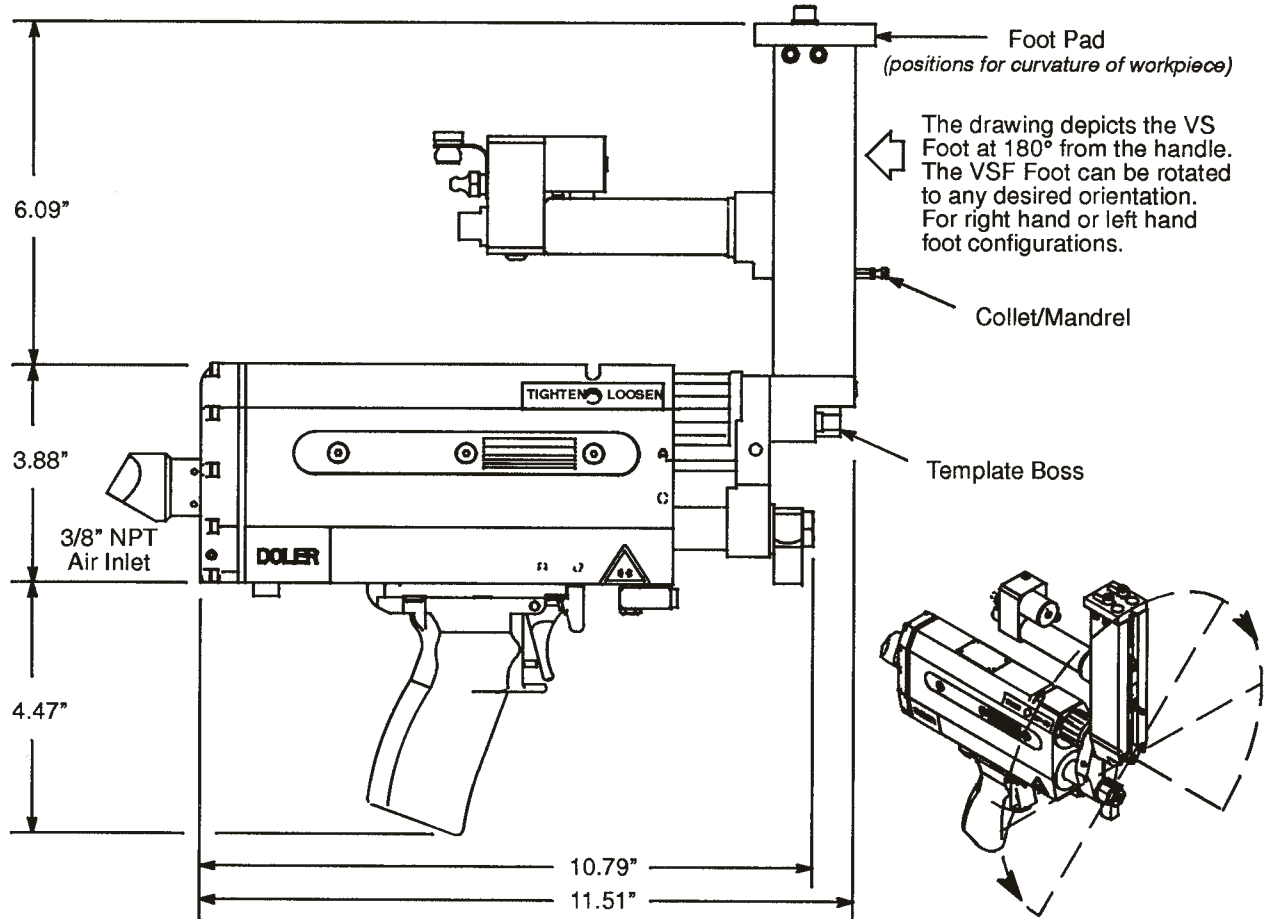

# Doler® Self Collecting Machines\*

## DOLER®

### P2 Drill with Concentric Collet Foot

- Simple and inexpensive fixturing
- Very rigid clamp up to your fixture
- No lock/unlock motion required
- No radial orientation of tooling required
- Bushing holes can overlap for closer spacing
- Micro Depth Adjustment - countersink depths within  $\pm .001$ "
- One or two handed operation
- 1.0 Horsepower motor
- Variety of spindle speeds and terminations to satisfy a wide range of applications

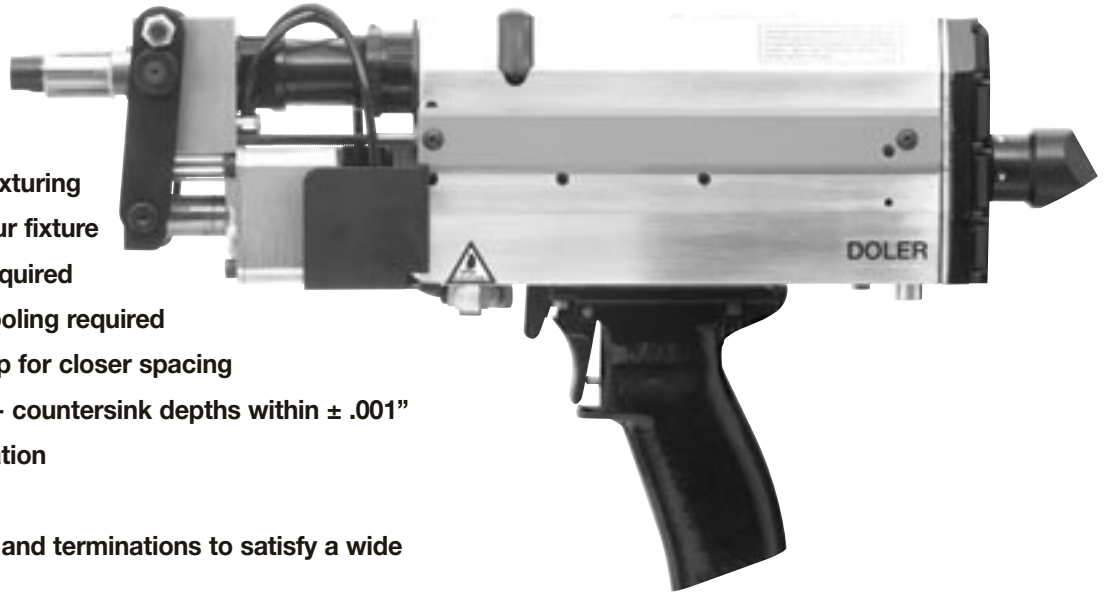

**P2 K A S 1 A I 22 1 312 X**

#### TOOL TYPE

K = Concentric Collet

#### VINTAGE

A, B, C, etc.

#### MOTOR/STROKE

#### SPINDLE SPEED

1 = 5200 RPM    5 = 1300RPM  
 2 = 3200 RPM    6 = 800 RPM  
 3 = 1900 RPM    7 = 500 RPM  
                     8 = 6000 RPM

#### SPINDLE TERMINATION

A = Ericksom 200 Collet Chuck  
 D = .25-28 x 0.375 "Spacematic"  
 E = .25-28 x 0.500 "Spacematic"  
 P = .375-24 Piloted External Thread (P.E.T.)

Note: Spindles D, E & P utilize 200 series collet with spindle adapter.

#### CUTTER COLLET DIAMETER

A = .125"    H = .234"    O = .344"  
 B = .141"    I = .25"    P = .359"  
 C = .156"    J = .266"    Q = .375"  
 D = .172"    K = .281"    R = .391"  
 E = .187"    L = .297"    X = None  
 F = .203"    M = .313"    Z = Prompt-Special  
 G = .219"    N = .328"    Diameter

Note: Cutters larger than .391 should have shank reduced.

#### ACCESSORY CODE

A = Drill Point Lubricator & Vacuum  
 L = Drill Point Lubricator  
 M = Handling Ring  
 V = Vacuum adapter  
 X = None

#### CUTTER GUIDE DIAMETER

Specify size in inches.  
 Example: 312 = .312 inches  
 (Use cutter body dia. of drill/c/sink)  
 (Use drillbit dia. for drill only)‡

#### SPECIAL STANDOFF

0 = 0.00            2 = 1.50  
 1 = Standard    3 = 2.00  
 (see chart)

#### CONCENTRIC COLLET SIZE

Code	Collecting Dia.	Collet Length	Standoff	Vacuum Port	Max. Cutter Dia.
20	.500	.50	.69	NO	.315
21	.500	1.00	1.38	NO	.199
60	.500	.50	.69	YES	.315
22	.594	1.00	1.38	NO	.335
62	.594	1.00	1.38	YES	.335
29	.625	.50	.69	NO	.437
69	.625	.50	.69	YES	.437
31	.625	1.00	1.38	NO	.365
23	.750	1.00	1.38	NO	.500
30	.750	.50	.69	NO	.547
63	.750	1.00	1.38	YES	.437
70	.750	.50	.69	YES	.547
24	.844	1.00	1.38	NO	.531
64	.844	1.00	1.38	YES	.531
25	.875	1.00	1.38	NO	.531
65	.875	1.00	1.38	YES	.531
26	1.000	1.00	1.38	NO	.587
66	1.000	1.00	1.38	YES	.587
28**	1.125	1.00	1.75	NO	.781
68**	1.125	1.00	1.75	YES	.781
27**	1.250	1.00	1.75	NO	.875
67**	1.250	1.00	1.75	YES	.875

\*Note: Complete Check Sheet on page 4-00 before placing order.  
 \*\*Note: Not available on P2 models.  
 ‡ Must specify Drill and Collet Size when placing order

**SPECIFICATIONS:**  
 Power: 1.0 hp  
 Air Consumption: 30 scfm  
 Air Inlet Size: .375 NPT  
 Recommended Hose Size: .5" I.D.  
 Thrust: 230 lbs. @ 90 psig

Depth Accuracy: Repeatable within  $\pm .001$ "  
 Stroke (overall): 1.0"  
 Length: 14.5" + Collet length  
 Weight: 9.0 lbs.

**EXTRA COST ACCESSORIES:**  
 Drill Point Lubricator (pg. 4-8)  
 Handling Ring (pg. 4-9)

# Doler® Self Collecting Machines

## Dimensional Data - P2 Drill w/ Concentric Collet Foot

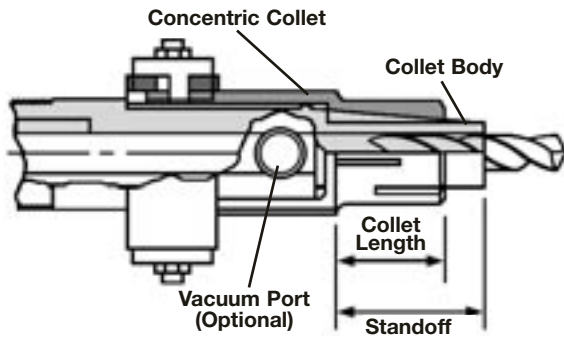
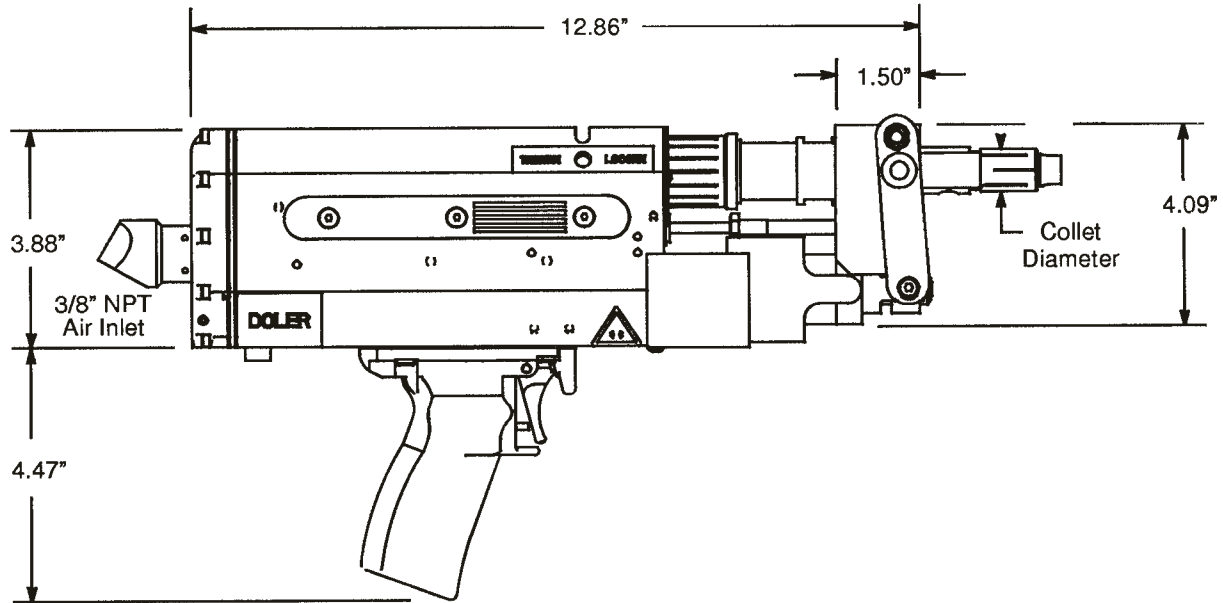

Standoff is the distance between the Concentric Collet shoulder and the end of the Collet body.

The holes in the Fixture Plate should be the nominal Collet diameter + .003, - .000.

When using Vacuum Collection, the Concentric Collet is moved outboard by .75". A .50" diameter vacuum collector port is provided in front of the Foot. A separate vacuum system can be attached to the vacuum port.

Refer to pages 14 and 15 for Concentric Collet tooling and operation.



## DOLER®

### Template Boss

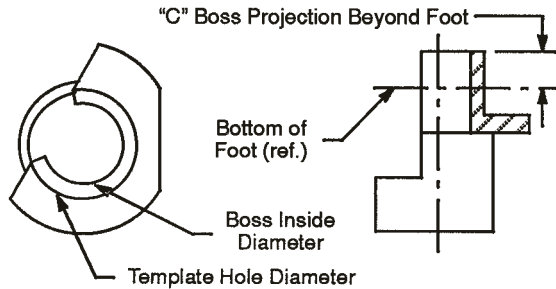

1. Determine Template Hole Diameter and Thickness.
2. Select the proper Template Boss from the chart below.
3. Boss projection "C" must be greater than Template Thickness.

Template Hole Dia.	Boss Projection "C"	Boss I.D.	Boss Part No.
.500	.062	.39	44-101-203
.500	.100	.39	44-101-212
.500	.150	.39	44-101-215
.500	.175	.39	44-101-255
.500	.200	.39	44-101-252
.500	.250	.39	44-101-261
.625	.062	.51	44-101-202
.625	.100	.51	44-101-211
.625	.150	.51	44-101-214
.625	.175	.51	44-101-223
.625	.200	.51	44-101-218
.625	.250	.51	44-101-260
.625	.300	.51	44-101-262
.750	.100	.64	44-101-210
.750	.150	.64	44-101-213
.750	.175	.64	44-101-282
.750	.200	.64	44-101-219

### P2 Drill Point Lubricator

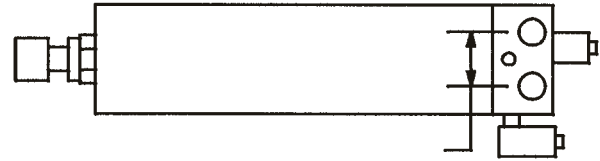

The Drill Point Lubricator provides lubricated air to the point of the cutter. The Doler PL Lubricator is mounted on the side of the P2 Main Module. The Drill Point Lubricator has a quick disconnect fitting for rapid no-mess refilling; use 80-503 Wall Tank to refill it or it can be filled manually and requires no additional equipment. Refer to page 16.

Assembly No.	Description
85-043	For P2 Variable Spacing Foot Models
85-050	For P2 Concentric Collet Models

Note: Assembly number is the complete assembly including P2 mounting hardware.

### Vacuum Pickup Attachment

Assembly No.	Description
56-027	Vacuum Shroud
17-194	Mounting Screw

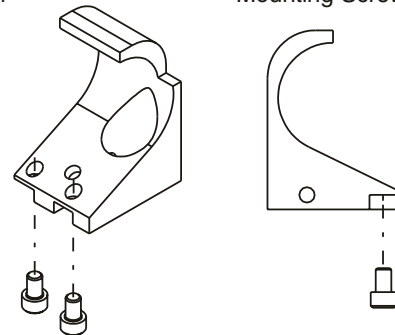

### Collets and Mandrels

Standard Duty (Used in Doler P2 Variable Spacing Foot Drill)

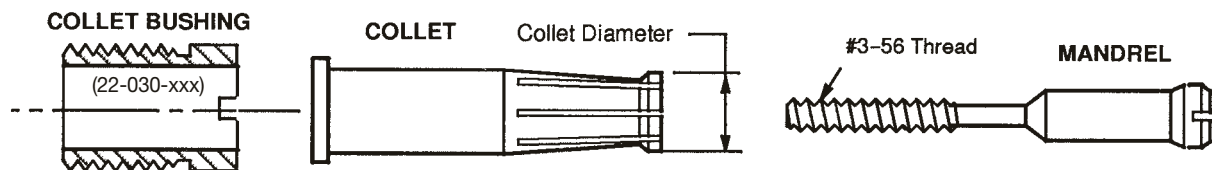

Grip Range*	Length Code**	Base Collet Number	Collet Overall Length	Base Mandrel Number	Mandrel Overall Length
0 - 0.10	- 23	46-051-xxx	1.15	46-151-xxx	2.25
0 - 0.30	- 40	46-052-xxx	1.40	46-152-xxx	2.50
0.20 - 0.56	- 63	46-053-xxx	1.65	46-153-xxx	2.75
0.45 - 0.81	- 90	46-054-xxx	1.92	46-154-xxx	3.00

\*Note: Complete Check Sheet on page 4- 00 before placing order.

1. Determine the maximum material thickness for the application. Select the Base Collet Number and Base Mandrel Number from the chart above.

2. Refer to page 4-9. Select the complete Collet and Mandrel number based on the pilot hole diameter in the workpiece.  
3. Order Collet Bushing 22-030-xxx where xxx is the Collet diameter.

\* NOTE: Material thickness or stack

\*\* NOTE: The Collet Code is an old numbering system still used by many customers. It is provided for reference.

## Doler P2 Collets and Mandrels

Min. Hole Size	Max. Hole Size	Collet Code	Collet Number	Mandrel Number
----------------	----------------	-------------	---------------	----------------

### Collets and Mandrels

0.1160	0.1210	.1160-23	46-051-116	46-151-120
0.1160	0.1210	.1160-40	46-052-116	46-152-120
0.1160	0.1210	.1160-63	46-053-116	46-153-120
0.1160	0.1210	.1160-90	46-054-116	46-154-120
0.1200	0.1250	.1200-23	46-051-120	46-151-120
0.1200	0.1250	.1200-40	46-052-120	46-152-120
0.1200	0.1250	.1200-63	46-053-120	46-153-120
0.1200	0.1250	.1200-90	46-054-120	46-154-120
0.1230	0.1280	.1230-23	46-051-123	46-151-125
0.1230	0.1280	.1230-40	46-052-123	46-152-125
0.1230	0.1280	.1230-63	46-053-123	46-153-125
0.1230	0.1280	.1230-90	46-054-123	46-154-125
0.1250	0.1300	.1250-23	46-051-125	46-151-125
0.1250	0.1300	.1250-40	46-052-125	46-152-125
0.1250	0.1300	.1250-63	46-053-125	46-153-125
0.1250	0.1300	.1250-90	46-054-125	46-154-125
0.1300	0.1350	.1300-23	46-051-130	46-151-125
0.1300	0.1350	.1300-40	46-052-130	46-152-125
0.1300	0.1350	.1300-63	46-053-130	46-153-125
0.1300	0.1350	.1300-90	46-054-130	46-154-125
0.1350	0.1400	.1358-23	46-051-135	46-151-140
0.1350	0.1400	.1358-40	46-052-135	46-152-140
0.1350	0.1400	.1358-63	46-053-135	46-153-140
0.1350	0.1400	.1358-90	46-054-135	46-154-140
0.1400	0.1450	.1406-23	46-051-140	46-151-140
0.1400	0.1450	.1406-40	46-052-140	46-152-140
0.1400	0.1450	.1406-63	46-053-140	46-153-140
0.1400	0.1450	.1406-90	46-054-140	46-154-140
0.1450	0.1500	.1458-23	46-051-145	46-151-140
0.1450	0.1500	.1458-40	46-052-145	46-152-140
0.1450	0.1500	.1458-63	46-053-145	46-153-140
0.1450	0.1500	.1458-90	46-054-145	46-154-140
0.1500	0.1560	.1510-23	46-051-150	46-151-156
0.1500	0.1560	.1510-40	46-052-150	46-152-156
0.1500	0.1560	.1510-63	46-053-150	46-153-156
0.1500	0.1560	.1510-90	46-054-150	46-154-156
0.1550	0.1620	.1562-23	46-051-156	46-151-156
0.1550	0.1620	.1562-40	46-052-156	46-152-156
0.1550	0.1620	.1562-63	46-053-156	46-153-156
0.1550	0.1620	.1562-90	46-054-156	46-154-156

Min. Hole Size	Max. Hole Size	Collet Code	Collet Number	Mandrel Number
----------------	----------------	-------------	---------------	----------------

### Collets and Mandrels

0.1600	0.1670	.1614-23	46-051-161	46-151-156
0.1600	0.1670	.1614-40	46-052-161	46-152-156
0.1600	0.1670	.1614-63	46-053-161	46-153-156
0.1600	0.1670	.1614-90	46-054-161	46-154-156
0.1655	0.1735	.1667-23	46-051-166	46-151-172
0.1655	0.1735	.1667-40	46-052-166	46-152-172
0.1655	0.1735	.1667-63	46-053-166	46-153-172
0.1655	0.1735	.1667-90	46-054-166	46-154-172
0.1710	0.1790	.1719-23	46-051-172	46-151-172
0.1710	0.1790	.1719-40	46-052-172	46-152-172
0.1710	0.1790	.1719-63	46-053-172	46-153-172
0.1710	0.1790	.1719-90	46-054-172	46-154-172
0.1765	0.1845	.1771-23	46-051-177	46-151-172
0.1765	0.1845	.1771-40	46-052-177	46-152-172
0.1765	0.1845	.1771-63	46-053-177	46-153-172
0.1765	0.1845	.1771-90	46-054-177	46-154-172
0.1815	0.1895	.1823-23	46-051-182	46-151-187
0.1815	0.1895	.1823-40	46-052-182	46-152-187
0.1815	0.1895	.1823-63	46-053-182	46-153-187
0.1815	0.1895	.1823-90	46-054-182	46-154-187
0.1865	0.1945	.1875-23	46-051-187	46-151-187
0.1865	0.1945	.1875-40	46-052-187	46-152-187
0.1865	0.1945	.1875-63	46-053-187	46-153-187
0.1865	0.1945	.1875-90	46-054-187	46-154-187
0.1915	0.1995	.1927-23	46-051-192	46-151-187
0.1915	0.1995	.1927-40	46-052-192	46-152-187
0.1915	0.1995	.1927-63	46-053-192	46-153-187
0.1915	0.1995	.1927-90	46-054-192	46-154-187
0.1970	0.2050	.1979-23	46-051-197	46-151-203
0.1970	0.2050	.1979-40	46-052-197	46-152-203
0.1970	0.2050	.1979-63	46-053-197	46-153-203
0.1970	0.2050	.1979-90	46-054-197	46-154-203
0.2025	0.2105	.2031-23	46-051-203	46-151-203
0.2025	0.2105	.2031-40	46-052-203	46-152-203
0.2025	0.2105	.2031-63	46-053-203	46-153-203
0.2025	0.2105	.2031-90	46-054-203	46-154-203
0.2075	0.2155	.2083-23	46-051-208	46-151-203
0.2075	0.2155	.2083-40	46-052-208	46-152-203
0.2075	0.2155	.2083-63	46-053-208	46-153-203
0.2075	0.2155	.2083-90	46-054-208	46-154-203

Continued on Page 4-10.

# Doler® Self Collecting Machines

## Doler P2 Collets and Mandrels

Min. Hole Size	Max. Hole Size	Collet Code	Collet Number	Mandrel Number
----------------	----------------	-------------	---------------	----------------

### Collets and Mandrels

0.2125	0.2205	.2135-23	46-051-213	46-151-219
0.2125	0.2205	.2135-40	46-052-213	46-152-219
0.2125	0.2205	.2135-63	46-053-213	46-153-219
0.2125	0.2205	.2135-90	46-054-213	46-154-219
0.2175	0.2255	.2188-23	46-051-219	46-151-219
0.2175	0.2255	.2188-40	46-052-219	46-152-219
0.2175	0.2255	.2188-63	46-053-219	46-153-219
0.2175	0.2255	.2188-90	46-054-219	46-154-219
0.2235	0.2315	.2240-23	46-051-224	46-151-219
0.2235	0.2315	.2240-40	46-052-224	46-152-219
0.2235	0.2315	.2240-63	46-053-224	46-153-219
0.2235	0.2315	.2240-90	46-054-224	46-154-219
0.2285	0.2365	.2292-23	46-051-229	46-151-234
0.2285	0.2365	.2292-40	46-052-229	46-152-234
0.2285	0.2365	.2292-63	46-053-229	46-153-234
0.2285	0.2365	.2292-90	46-054-229	46-154-234
0.2335	0.2415	.2344-23	46-051-234	46-151-234
0.2335	0.2415	.2344-40	46-052-234	46-152-234
0.2335	0.2415	.2344-63	46-053-234	46-153-234
0.2335	0.2415	.2344-90	46-054-234	46-154-234
0.2385	0.2465	.2396-23	46-051-239	46-151-234
0.2385	0.2465	.2396-40	46-052-239	46-152-234
0.2385	0.2465	.2396-63	46-053-239	46-153-234
0.2385	0.2465	.2396-90	46-054-239	46-154-234
0.2435	0.2515	.2448-23	46-051-245	46-151-250
0.2435	0.2515	.2448-40	46-052-245	46-152-250
0.2435	0.2515	.2448-63	46-053-245	46-153-250
0.2435	0.2515	.2448-90	46-054-245	46-154-250
0.2485	0.2565	.2500-23	46-051-250	46-151-250
0.2485	0.2565	.2500-40	46-052-250	46-152-250
0.2485	0.2565	.2500-63	46-053-250	46-153-250
0.2485	0.2565	.2500-90	46-054-250	46-154-250
0.2545	0.2625	.2552-23	46-051-255	46-151-250
0.2545	0.2625	.2552-40	46-052-255	46-152-250
0.2545	0.2625	.2552-63	46-053-255	46-153-250
0.2545	0.2625	.2552-90	46-054-255	46-154-250
0.2595	0.2675	.2604-23	46-051-260	46-151-265
0.2595	0.2675	.2604-40	46-052-260	46-152-265
0.2595	0.2675	.2604-63	46-053-260	46-153-265
0.2595	0.2675	.2604-90	46-054-260	46-154-265

Min. Hole Size	Max. Hole Size	Collet Code	Collet Number	Mandrel Number
----------------	----------------	-------------	---------------	----------------

### Collets and Mandrels

0.2645	0.2725	.2656-23	46-051-265	46-151-265
0.2645	0.2725	.2656-40	46-052-265	46-152-265
0.2645	0.2725	.2656-63	46-053-265	46-153-265
0.2645	0.2725	.2656-90	46-054-265	46-154-265
0.2695	0.2775	.2708-23	46-051-271	46-151-265
0.2695	0.2775	.2708-40	46-052-271	46-152-265
0.2695	0.2775	.2708-63	46-053-271	46-153-265
0.2695	0.2775	.2708-90	46-054-271	46-154-265
0.2745	0.2825	.2760-23	46-051-276	46-151-281
0.2745	0.2825	.2760-40	46-052-276	46-152-281
0.2745	0.2825	.2760-63	46-053-276	46-153-281
0.2745	0.2825	.2760-90	46-054-276	46-154-281
0.2805	0.2885	.2812-23	46-051-281	46-151-281
0.2805	0.2885	.2812-40	46-052-281	46-152-281
0.2805	0.2885	.2812-63	46-053-281	46-153-281
0.2805	0.2885	.2812-90	46-054-281	46-154-281
0.2855	0.2935	.2864-23	46-051-286	46-151-281
0.2855	0.2935	.2864-40	46-052-286	46-152-281
0.2855	0.2935	.2864-63	46-053-286	46-153-281
0.2855	0.2935	.2864-90	46-054-286	46-154-281
0.2905	0.2985	.2916-23	46-051-291	46-151-297
0.2905	0.2985	.2916-40	46-052-291	46-152-297
0.2905	0.2985	.2916-63	46-053-291	46-153-297
0.2905	0.2985	.2916-90	46-054-291	46-154-297
0.2955	0.3035	.2969-23	46-051-297	46-151-297
0.2955	0.3035	.2969-40	46-052-297	46-152-297
0.2955	0.3035	.2969-63	46-053-297	46-153-297
0.2955	0.3035	.2969-90	46-054-297	46-154-297
0.3015	0.3095	.3021-23	46-051-302	46-151-297
0.3015	0.3095	.3021-40	46-052-302	46-152-297
0.3015	0.3095	.3021-63	46-053-302	46-153-297
0.3015	0.3095	.3021-90	46-054-302	46-154-297
0.3065	0.3145	.3043-23	46-051-307	46-151-312
0.3065	0.3145	.3043-40	46-052-307	46-152-312
0.3065	0.3145	.3043-63	46-053-307	46-153-312
0.3065	0.3145	.3043-90	46-054-307	46-154-312
0.3115	0.3195	.3125-23	46-051-312	46-151-312
0.3115	0.3195	.3125-40	46-052-312	46-152-312
0.3115	0.3195	.3125-63	46-053-312	46-153-312
0.3115	0.3195	.3125-90	46-054-312	46-154-312

## P3 Series Portable Drilling Machines

### **Portable**

Doler P3 Portable Power Feed Drills are used where the Drilling Machine must be taken to the workpiece.

Aerospace assemblies and other bulky parts that require precision drilling are typical applications.

### **Automatic**

Integral clamping mechanism rigidly mounts the power unit in the proper position. After clamping itself to the workpiece, or fixture, the P3 drills, countersinks and retracts - rapidly and automatically.

### **Accurate**

With proper cutting tools and lubrication, a .375" diameter hole with .500" diameter countersink can be produced in 3/4" thick aluminum in 5 seconds - with excellent hole finish and depth accuracy. The two-horse power motor provides drilling capacity to produce hole diameters to  $\varnothing$  .625" with

countersink, diameters to  $\varnothing$  930" in aluminum with the same excellent finish and depth accuracy. A similar hole in titanium can be produced in less than a minute.

### **Modular Design**

The Doler P3 is uniquely designed and built to provide the highest degree of accuracy and productivity. The modular design allows rapid changeover from one application to the next - plus easy servicing and maintenance.

### **Versatility**

Spindles with various threaded shanks are available. Erickson 200 Collet Chucks will secure straight shank cutters. Virtually any style of cutting tool can be utilized. The pneumatic logic control insures that clamp-up is completed before the spindle advances and the spindle retracts before unclamping occurs. The spindle rotates during retract to avoid cutter withdrawal blemishes.

A dependable pneumatic motor gives high performance, efficient use of compressed air and excellent serviceability. A two horsepower motor is available for drilling large diameters in tough materials. Housings are produced from durable, high strength bar stock aluminum.

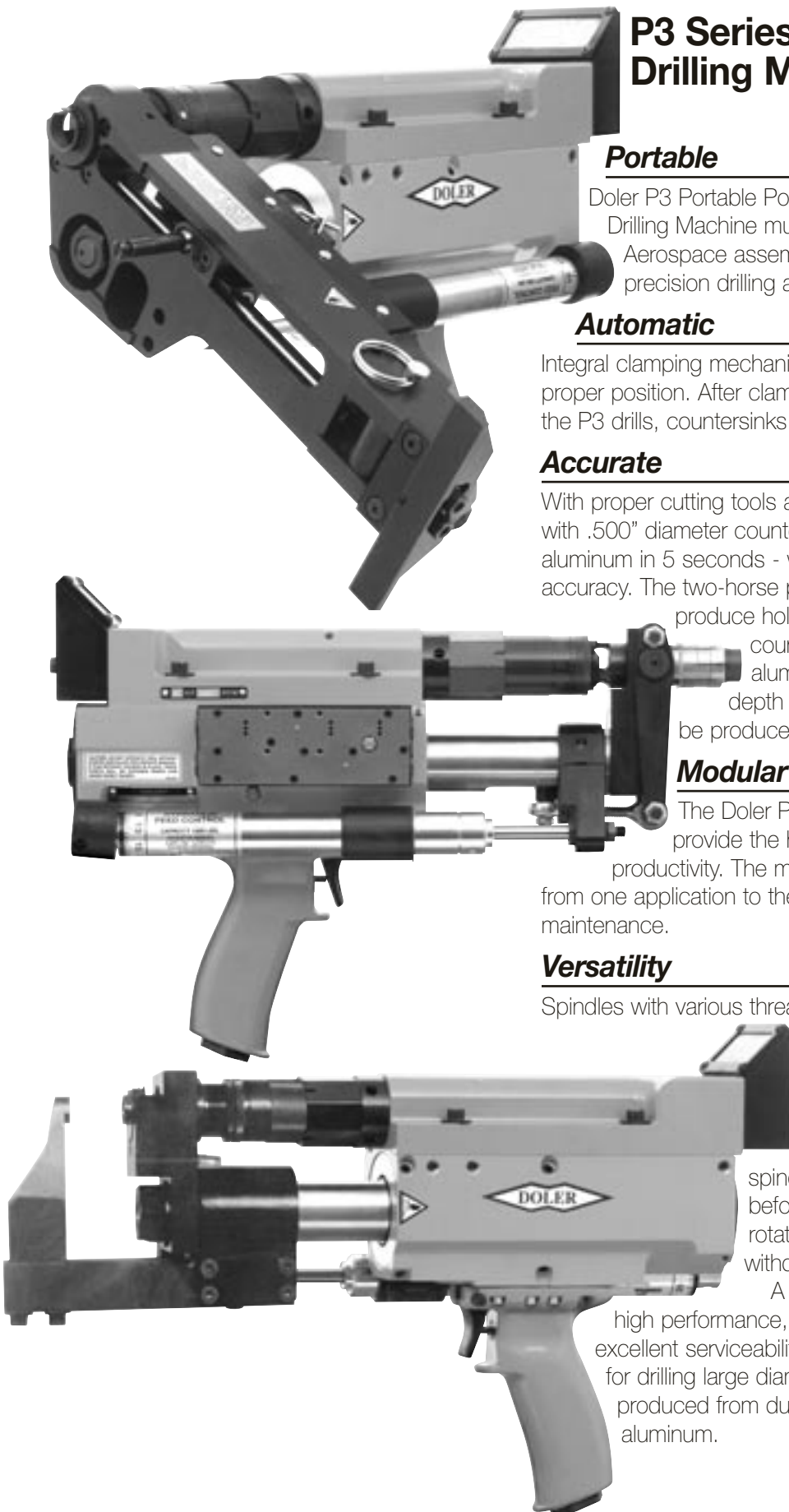

# Doler® Self Collecting Machines\*

## DOLER®

### P3 Drill with Variable Spacing Foot

■ Thrust and power to drill up to .750" in diameter hole with a .930" countersink a aluminum or a .500" diameter hole with .750" countersink in titanium.

■ Variety of spindle speeds and terminations to satisfy a wide range of applications

■ Infinite feed rate control

■ Drill point lubrication

■ Positive depth stop for countersink accuracy

■ Rigid and precise spindle for excellent hole quality and finish

■ Compact and Light weight

■ Low noise

■ Good balance and comfortable grip

■ Rotating cutter/countersink guide for



P3	3	2	-	16	E	2	-	2	2	W	
----	---	---	---	----	---	---	---	---	---	---	--

#### FEED STROKE

2 = 2" Stroke  
3 = 1.25" Stroke  
4 = 3" Stroke

#### SPINDLE SPEED (X)

0 = 480 RPM	3 = 3600 RPM	6 = 6800 RPM
1 = 725 RPM	4 = 3000 RPM	8 = 2500 RPM
2 = 1050 RPM	5 = 5200 RPM	9 = 320 RPM

#### FOOT ATTACHMENT (XX)

15 = "101" LH Variable Spacing Foot  
16 = "101" RH Variable Spacing Foot  
17 = "100" LH Variable Spacing Foot  
18 = "100" RH Variable Spacing Foot

#### SPINDLE (X)

A = Erickson 200 Collet Chuck  
B = Erickson 200 Collet Chuck with Coolant Spindle  
D = .25-28 x 0.375 "Spacematic"  
E = .25-28 x 0.500 "Spacematic"  
F = .25-28 x 0.625 "Spacematic"  
P = .375-24 x 0.500 Piloted External Thread (P.E.T.)  
Q = .375-24 Piloted External Thread (P.E.T.) with through the spindle coolant

#### BOOSTER

B = Booster  
Leave blank for none

#### DEPTH ADJUSTMENT (X)

W = Wrenchless

#### COLLET PILOT DIAMETER (X)

1 = .323 Pilot  
2 = .437 Pilot  
3 = .471 Pilot

#### CUTTER GUIDE DIAMETER (X)‡

1 = .375 Diameter	5 = .650 Diameter
2 = .500 Diameter	6 = .930 Diameter
3 = .625 Diameter	9 = Other, specify
4 = .750 Diameter	

#### MOTOR POWER (X)

1 = One Horsepower  
2 = Two Horsepower (Speed codes 6, 8, & 9 are not available.)

\*Note: Complete Check Sheet on page 4- 00 before placing order.

‡ Must specify Drill and Collet size when placing order

#### SPECIFICATIONS:

Air Consumption: 35 scfm (1.0 HP)  
65 scfm (2.0 HP)  
Air Inlet Size: .375 NPT (1.0 HP)  
.5 NPT (2.0 HP)  
Recommended Hose Size: .5" I.D. (1.0 HP)  
.75" I.D. (2.0 HP)

Thrust: 320 lbs. @ 80 psig; w/booster 575lbf.  
Depth Accuracy: Repeatable within .001"

Weight: P32 - 14.9 lbs.  
P33 - 13.7 lbs.  
P34 - 16.2 lbs.

Capacity - Diameter  
Aluminum -.75 hole (18mm) with .930 (25mm) countersink  
Titanium -.50 hole (13mm) with .75 (18mm) countersink

#### OPTIONAL EQUIPMENT (see pages 4-18 thru 4-26)

Template Boss  
Clamping Collet/Mandrel  
Foot Pad  
Erickson 200 Collet

#### EXTRA COST ACCESSORIES (See pages 4-20 thru 4-22)

Drill Point Lubricator  
Handling Ring  
Venturi Vacuum  
Vacuum Adapter

## Dimensional Data - P3 Drill with Variable Spacing Foot

### HEAVY DUTY COLLETS AND MANDRELS

Collets and Mandrels are available to accommodate virtually any hole diameter and material thickness.

Each size can clamp on thickness variations of .4".

Refer to page 4-22 for a complete list of heavy duty Collets and Mandrels.

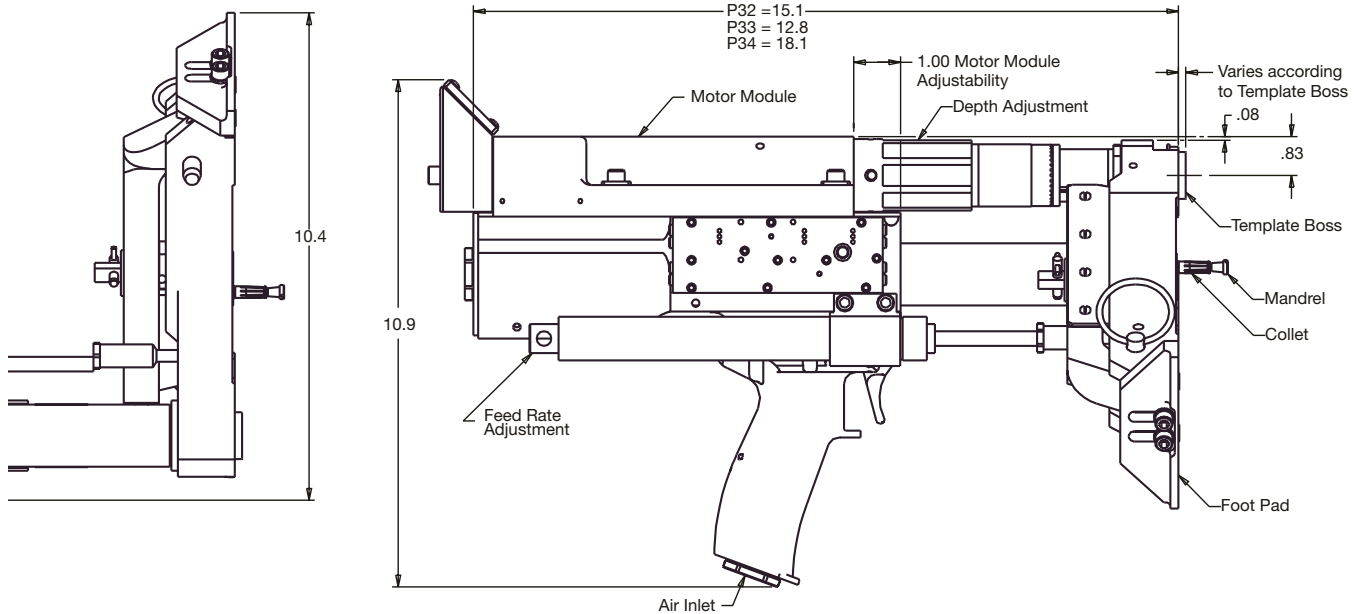

### Operation

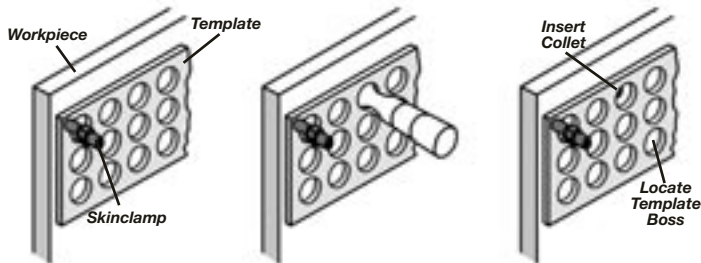

1. Position and clamp the drilling template on the workpiece.

2. Drill the first hole by conventional means.

3. Insert the Collet into the first hole and locate the Template Boss in the drilling template. Insure that the Collet/Mandrell extends through the workpiece.

4. Depress the trigger. Immediately, the Mandrel is drawn back and the Collet locks the tool to the work. Simultaneously, the motor starts and the tool feeds forward to a positive stop. The tool then retracts automatically and returns to its starting position.
5. Release the trigger; the motor shuts off and unclamping occurs.
6. Reposition the Boss and drill other holes within the collecting Range.
7. Withdraw the Collet/Mandrell and insert into a recently drilled hole. Repeat steps 3 through 6.

Model	Attachment No.		Hole Spacing Range	Spindle Offset Side-To-Center
	Left-Right	Right-Left		

### Variable Spacing Foot Specifications

100	80-419	80-405	1.0-5.6	.75
101	80-478	80-479	1.0-5.6	.75

The 100 VSF is at a right angle to the P3 handle and is preferred in open areas.

The 101 VSF is approximately 45° from the P3 handle and is preferred in confined areas.

# Doler® Self Collecting Machines\*

## DOLER®

### P3 Drill with Concentric Collet

- Simple and inexpensive fixturing
- Very rigid clamp up to your fixture
- No lock/unlock motion required
- Infinite feed control rate
- No radial orientation of tooling is required
- Bushing holes can overlap for closer spacing
- Micro Depth Adjustment - depths within .001"
- 1.0" spindle axial location adjustment
- Complete range of colleting diameters, colleting lengths, standoffs, and vacuum access.
- Full range of speeds. Select a 1 or 2 hp motor

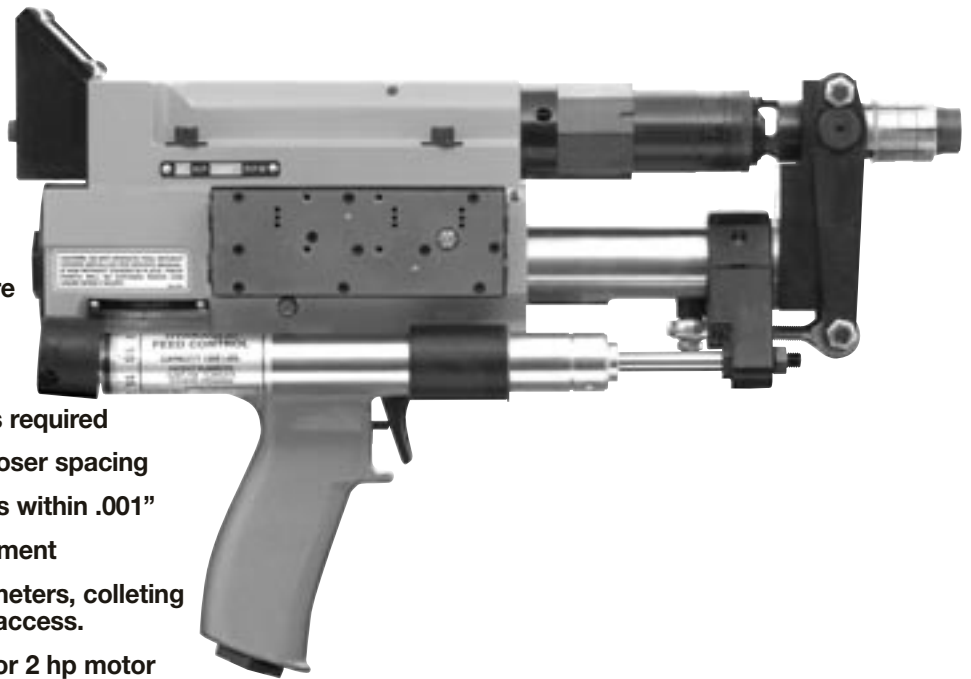

P3	3	3	-	26	A	2	-	312	C	1	B
----	---	---	---	----	---	---	---	-----	---	---	---

#### FEED STROKE (X)

2 = 2" Stroke  
3 = 1.25" Stroke  
4 = 3" Stroke

#### SPINDLE SPEED (X)

0 = 480 RPM	5 = 5200 RPM	6 = 6800 RPM
1 = 725 RPM	4 = 3000 RPM	8 = 2500 RPM
2 = 1050 RPM	3 = 3600 RPM	9 = 320 RPM

#### CONCENTRIC COLLET FOOT ATTACH. (XX)

Code	Colleting Dia.	Collet Length	Standoff	Vacuum Port	Max. Cutter Dia.
20	.500	.50	.69	NO	.315
21	.500	1.00	1.38	NO	.199
60	.500	.50	.69	YES	.315
22	.594	1.00	1.38	NO	.335
62	.594	1.00	1.38	YES	.335
29	.625	.50	.69	NO	.437
69	.625	.50	.69	YES	.437
31	.625	1.00	1.38	NO	.365
23	.750	1.00	1.38	NO	.500
30	.750	.50	.69	NO	.547
63	.750	1.00	1.38	YES	.437
70	.750	.50	.69	YES	.547
24	.844	1.00	1.38	NO	.531
64	.844	1.00	1.38	YES	.531
25	.875	1.00	1.38	NO	.531
65	.875	1.00	1.38	YES	.531
26	1.000	1.00	1.38	NO	.587
66	1.000	1.00	1.38	YES	.587
28**	1.125	1.00	1.75	NO	.781
68**	1.125	1.00	1.75	YES	.781
27**	1.250	1.00	1.75	NO	.875
67**	1.250	1.00	1.75	YES	.875
00	No Foot Attachment				

#### BOOSTER

##### STANDOFF (X)

0 = 0.0  
1 = Standard (see chart)  
2 = 0.50  
3 = 1.00  
7 = 2.16  
8 = 2.66

##### CUTTER TYPE

D = Drill only  
C = Countersink

##### CUTTER GUIDE DIAMETER (XXX)‡

Specify size in inches.  
Example: 312 = .312 inches  
(Use cutter body dia. of drill/c/sink)  
(Use drillbit dia. for drill only)

##### MOTOR POWER (X)

1 = One Horsepower  
2 = Two Horsepower  
(Speed codes 6, 8, & 9 are not available.)

##### SPINDLE (X)

A = Erickson 200 Collet Chuck  
B = Erickson 200 Collet Chuck with Coolant Spindle  
D = .25-28 x 0.375 "Spacematic"  
E = .25-28 x 0.500 "Spacematic"  
F = .25-28 x 0.625 "Spacematic"  
P = .375-24 x 0.500 Piloted External Thread (P.E.T.)  
Q = .375-24 Piloted External Thread (P.E.T.) with through the spindle coolant  
(NOTE: D thru Q use Erickson Chuck + proper spindle adapter.)

\*Note: Complete Check Sheet on page 4- 00 before placing order.

\*\*Note: Not available on P2 models.

‡ Must specify Drill and Collet Size when placing order

#### SPECIFICATIONS:

Air Consumption: 35 scfm (1.0 HP)  
65 scfm (2.0 HP)  
Air Inlet Size: .375 NPT (1.0 HP)  
.5 NPT (2.0 HP)

Recommended Hose Size: .5" I.D. (1.0 HP)  
.75" I.D. (2.0 HP)

Thrust: 320 lbs. @ 80 psig; w/booster 595 lbf.

Depth Accuracy: Repeatable within .001"

Capacity - Diameter

Aluminum -.75 hole (18mm) with .930 (25mm)

countersink

Titanium -.50 hole (13mm) with .75 (18mm)

countersink

Weight: P32 - 13.6 lbs.

P33 - 12.4 lbs.

P34 - 14.9 lbs.

EXTRA COST ACCESSORIES (See pages 4-18 thru 4-26)

Drill Point Lubricator

Handling Ring

Venturi Vacuum

Erickson 200 collet

## Dimensional Data - P3 Drill with Concentric Collet

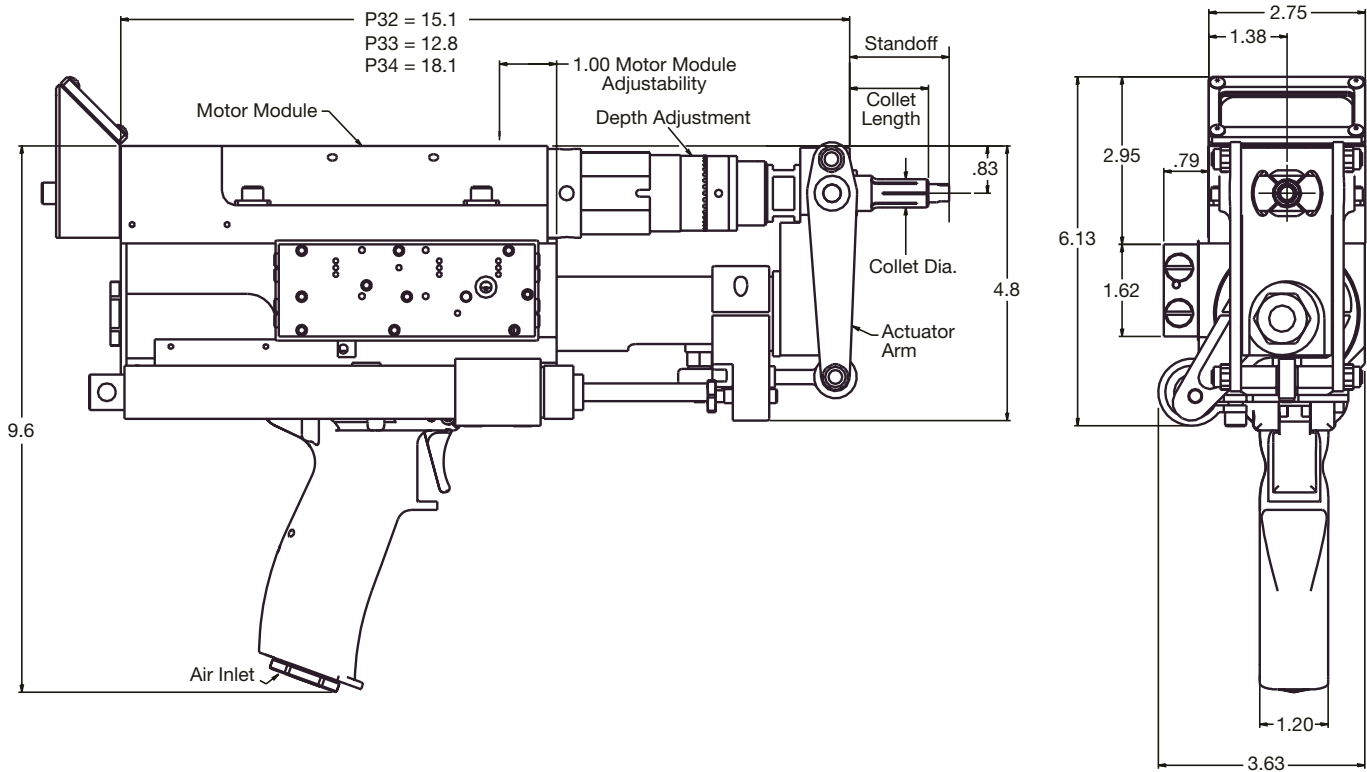

Standoff is the distance between the Fixture Plate and Workpiece. It is necessary to provide a clearance area for chips (swarf).

The holes in the Fixture Plate should be the nominal Collet diameter + .003, - .000.

When using Vacuum Collection, the Concentric Collet is moved outboard by .75". A .50" diameter vacuum collector port is provided in front of the Foot. The Venturi Vacuum accessory or a separate vacuum system can be attached to the vacuum port.

Refer to pages 14 and 15 for Concentric Collet tooling and operation.



# Doler® Self Collecting Machines\*

## DOLER®

### P3 Drill with "C" Foot

■ Simple and inexpensive fixturing

■ Workpiece is rigidly clamped while drilling and countersinking is performed

■ No lock/unlock motion required

■ No radial orientation of tooling required

■ Cutting tool is piloted by a rotating guide for maximum cutter life and excellent hole quality

■ Micro Depth Adjustment - maintains countersink depths within .001"

■ 1.0" spindle axial location adjustment to position drill point



P3	3	3	-	41	A	2	-	2	2
----	---	---	---	----	---	---	---	---	---

#### FEED STROKE (X)

2 = 2" Stroke  
3 = 1.25" Stroke  
4 = 3" Stroke

#### SPINDLE SPEED (X)

0 = 480 RPM	5 = 5200 RPM	6 = 6800 RPM
1 = 725 RPM	4 = 3000 RPM	8 = 2500 RPM
2 = 1050 RPM	3 = 3600 RPM	9 = 320 RPM

#### "C" Foot Attachment (XX)

41 = Mini "C", 1.6 yoke depth  
42 = Regular "C", 3.0 yoke depth

#### CUTTER GUIDE DIA. (X)‡

1 = .375 dia. 3 = .625 dia.  
2 = .500 dia. 4 = .750 dia.

#### YOKE OPENING

1 = 1.0"	4 = 2.5"
2 = 1.5"	5 = 3.0"
3 = 2.0"	6 = 3.5"

#### MOTOR POWER (X)

1 = One Horsepower  
2 = Two Horsepower  
(Speed codes 6, 8, & 9 are not available.)

#### SPINDLE (X)

A = Erickson 200 Collet Chuck  
B = Erickson 200 Collet Chuck with Coolant Spindle  
D = 1/4-28 x 0.375 Spacematic  
E = 1/4-28 x 0.500 Spacematic  
F = 1/4-28 x 0.625 Spacematic  
Note: D-F use Erickson chuck and proper spindle adapter

\*Note: Complete Check Sheet on page 4-00 before placing order.

‡ Must specify Drill/CS when placing order

#### SPECIFICATIONS:

Air Consumption: 35 scfm (1.0 HP)  
65 scfm (2.0 HP)  
Air Inlet Size: .375 NPT (1.0 HP)  
.5 NPT (2.0 HP)  
Recommended Hose Size: .5" I.D. (1.0 HP)  
.75" I.D. (2.0 HP)

Thrust: 320 lbs. @ 80 psig  
Depth Accuracy: Repeatable within .001"  
Capacity - Diameter  
Aluminum -.625 hole (18mm) with .930 (25mm) countersink  
Titanium -.50 hole (13mm) or .625 countersink

Weight: P32 - 13.8 lbs.  
P33 - 12.6 lbs.  
P34 - 15.1 lbs.

#### OPTIONAL EQUIPMENT (See pages 4-20 thru 4-22)

Template Boss (pg. 4-18)  
Backup Pad  
Spring-loaded pilot swivel pad

#### EXTRA COST ACCESSORIES (See pages 4-20 thru 4-22)

Drill Point Lubricator  
Handling Ring  
Venturi Vacuum

# Doler® Self Collecting Machines

## Dimensional Data - P3 Drill with "C" Foot

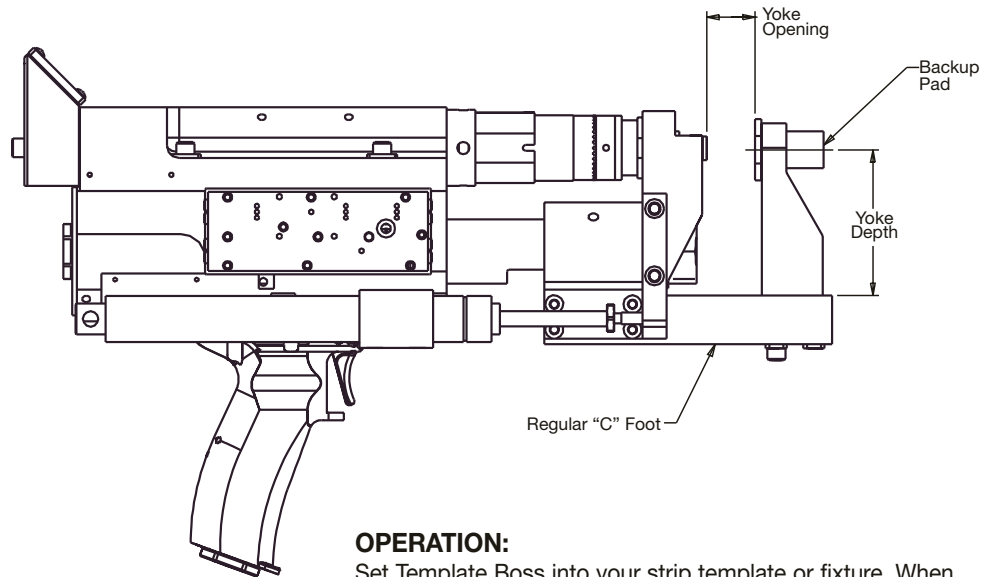
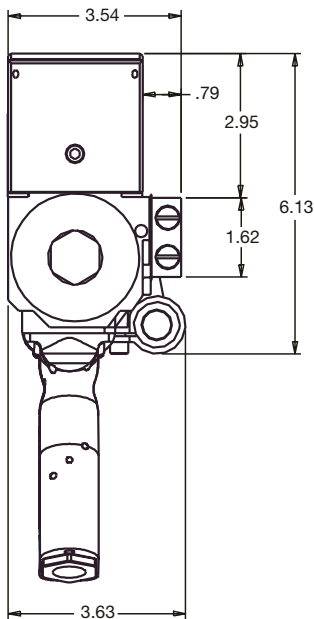

### OPERATION:

Set Template Boss into your strip template or fixture. When the trigger is pulled the backup pad is pulled firmly against the rear surface of the workpiece.

Immediately, the motor starts and the P3 drills and countersinks to set depth and retracts. When the trigger is released, the motor stops and unclamping occurs.

## "C" Foot Optional Equipment

### Spring Loaded Pilot

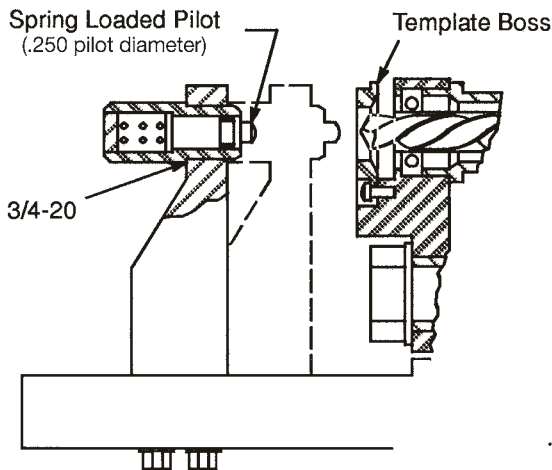

### "Mini C" Foot

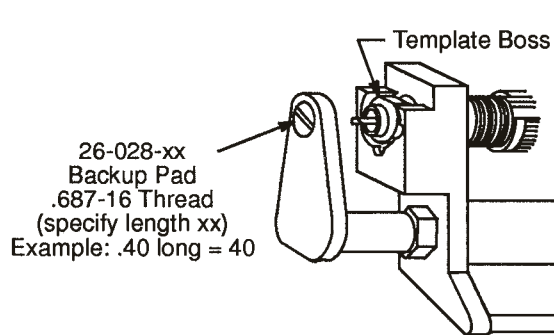

### Swivel Backup Pad

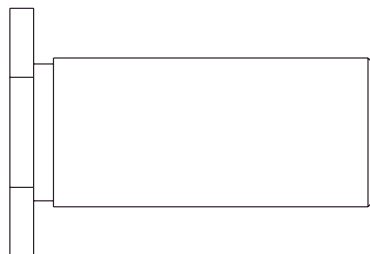
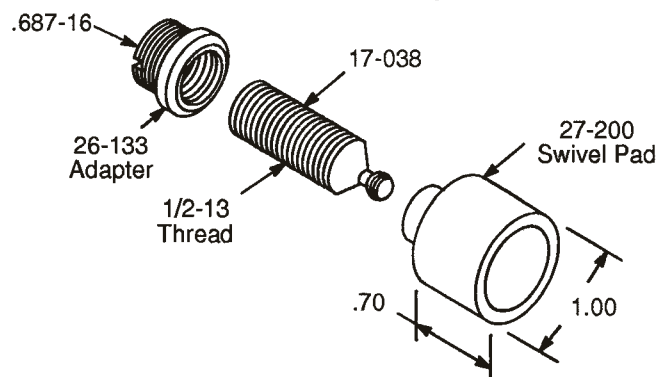

### Backup Pad

26-071-xxx ("xxx" specify length, ie. 225=2.25")

# Doler Self Collecting Machines Accessories

## PL Drill Point Lubricator 85-044

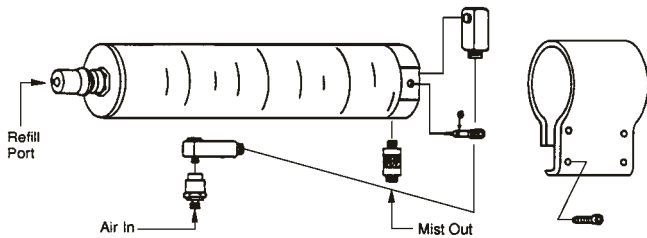

The Drill Point Lubricator provides lubricated air to the point of the cutter. The Doler PL Lubricator is mounted on the Control Valve Module. The Drill Point Lubricator has a quick disconnect fitting for rapid no-mess refilling; use 80-503 Wall Tank to refill it or it can be filled manually and requires no additional equipment. Refer to page 17.

## Adjustable Foot Pad 80-897 for 101 Foot 80-925 for 100 Foot

The Foot Pad levels the Variable Spacing Foot so that the drilled hole is perpendicular to the surface. The projection length of the Foot Pad (xx) depends upon the projection length of the Template Boss, thickness of the Template and radius of the workpiece. See service literature for diagram.

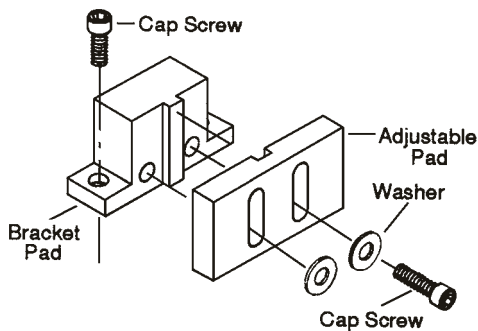

## Wall Tank

The 80-503 Wall Tank (2 gallon) can be conveniently located in the work area or tool crib. The Drill Point Lubricator can then be refilled via the quick disconnect fitting (included).

Boelube®, Microlube®, or similar cutting lubricants work very well. A very small amount is required to properly lubricate the cutting tool.

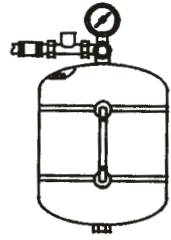

## Template Boss

1. Determine Template Hole Diameter and Thickness.
2. Select the proper Template Boss from the chart below.
3. Boss length "L" must be greater than Template Thickness.

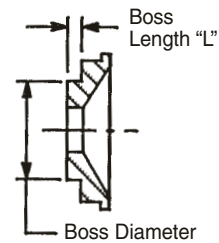

Template Hole Dia.	Boss Projection "C"	Boss I.D.	Boss Part No.
.500	.062	.39	44-203
.500	.100	.39	44-212
.500	.150	.39	44-215
.625	.062	.51	44-202
.625	.100	.51	44-211
.625	.150	.51	44-214
.750	.100	.64	44-210
.750	.150	.64	44-213
.875	.150	.69	44-221
.875	.200	.69	44-259
1.000	.080	.81	44-222
1.000	.100	.81	44-208
1.000	.150	.81	44-209
1.000	.175	.81	44-281
1.125	.100	1.00	44-204
1.125	.150	1.00	44-220
1.250	.200	1.12	44-253

Other combinations of Hole Diameter (1.25" max.) and Length "L" can be provided.

## Handling Ring (for P2 and P3 Drills)

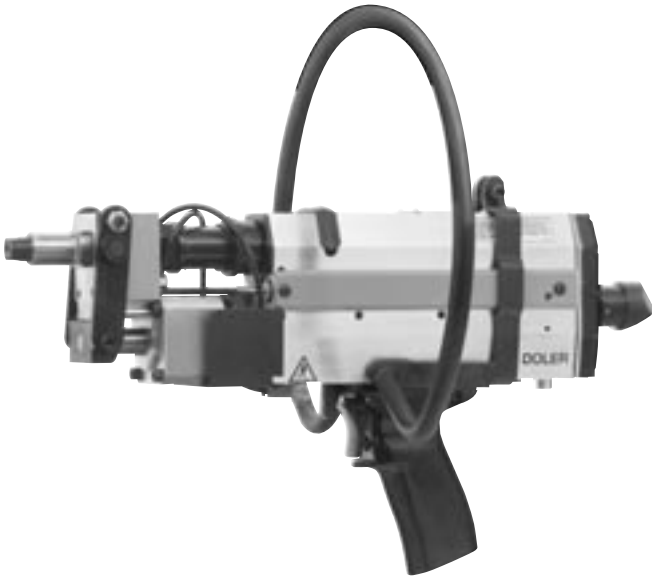

A 9" diameter, rubber covered, ring that encircles and protects the P3 when it is laid down. It also provides a convenient way to carry the tool. The Handling Ring can be used with an overhead balancer to put the spindle in a horizontal position.

- Handling Ring number 58-316 fits the P33.**
- Handling Ring number 58-271-02 fits the P32 and P34.**
- Handling Ring number 56-095 fits the P2.**

## Spindle Adapters

Spindle Adapter for Threaded Shank Cutters (use with number 212 Collet)

Part Number	Thread x Body Diameter	Overall Length
32-009	.25"-28 x 0.375"	2.4
32-048	.25"-28 x 0.375"	4.0
32-049	.25"-28 x 0.375"	6.0
32-050-1	.25"-28 x 0.500"	2.5
32-050-2	.25"-28 x 0.500"	4.0
32-050-3	.25"-28 x 0.500"	3.5
32-050-4	.25"-28 x 0.500"	5.0
32-050-5	.25"-28 x 0.500"	4.2
32-050-6	.25"-28 x 0.500"	5.7
32-050-7	.25"-28 x 0.500"	5.2
32-050-8	.25"-28 x 0.500"	6.7
32-050-9	.25"-28 x 0.500"	4.7
32-071-1	.25"-28 x 0.625"	2.5
32-071-2	.25"-28 x 0.625"	4.0
32-071-3	.25"-28 x 0.625"	3.5
32-071-4	.25"-28 x 0.625"	5.0
32-071-5	.25"-28 x 0.625"	4.2
32-071-6	.25"-28 x 0.625"	5.7

## Spindle Collets



Part No.	Size	
<b>Series 200 Collets</b>		
204	.125"	0.125
46-500-141	.1406"	0.141
205	.1563"	0.156
46-500-172	.1719"	0.172
206	.1875"	0.187
46-500-203	.2031"	0.203
207	.2188"	0.219
46-500-234	.2344"	0.234
213	6 mm	0.236
208	.25"	0.250
46-500-265	.2656"	0.265
209	.2813"	0.281
46-500-297	.2969"	0.297
210	.3125"	0.313
46-500-328	.3281"	0.328
211	.3438"	0.344
46-500-359	.3594"	0.359
212	.375"	0.375
46-500-390	.3906"	0.390

Add "C" to the part number for use with Thru-the-Spindle Coolant. Slots are filled with elastomer.

## 82-135 Venturi Vacuum (for P3 Drills)

Replace the motor muffler. The air motor exhaust is routed through a venturi port to create a vacuum. The vacuum is then used to pick up dust and small chips that are hazardous to the environment. The dust and chips are collected in a disposable bag.

## 27-055 Inlet Manifold (for P3 Drills)

Used when mounting the P3 for stationary applications. Provides two NPT ports for using an external 4-way valve. Replaces the handle.

## 527696 Foot Valve (for P3 Drills)

Spring loaded 4-way valve: can be used with 27-055 Manifold for Foot operation of the P3. Includes foot shield.

## 82-104 Rear Bail (for P3 Drills)

A convenient mount for an overhead balancer. Puts the spindle of the P3 in the vertical position.

## DOLER®

### Clamping Collets and Mandrels for P3 Drills with Variable Spacing Foot

Clamping Collets and Mandrels are the components that are inserted into existing holes and then clamp the Doler P3 to the workpiece.

At cycle start, the Mandrel is rapidly pulled, expanding the front flange on the collet then pulling back until the collet clamps firmly on the rear side of the workpiece.

The Collet diameter must match the drilled hole diameter to facilitate clamp-up and installation/removal. The collet grip length must accommodate the thickest section of material to be drilled. The Grip Range (pull-up

stroke) provides for clamping on thinner sections.

A given collet works in a narrow diameter and grip range. Consequently, there are a lot of collets and mandrels required to cover the range of holes to be drilled.

NOTE: Doler Mandrels are interchangeable with competitive Mandrels. Doler Collets taper between the collecting diameter and pilot diameter. This is necessary for smooth operation. Competitive Collets have a sharp step but can be modified to work properly.

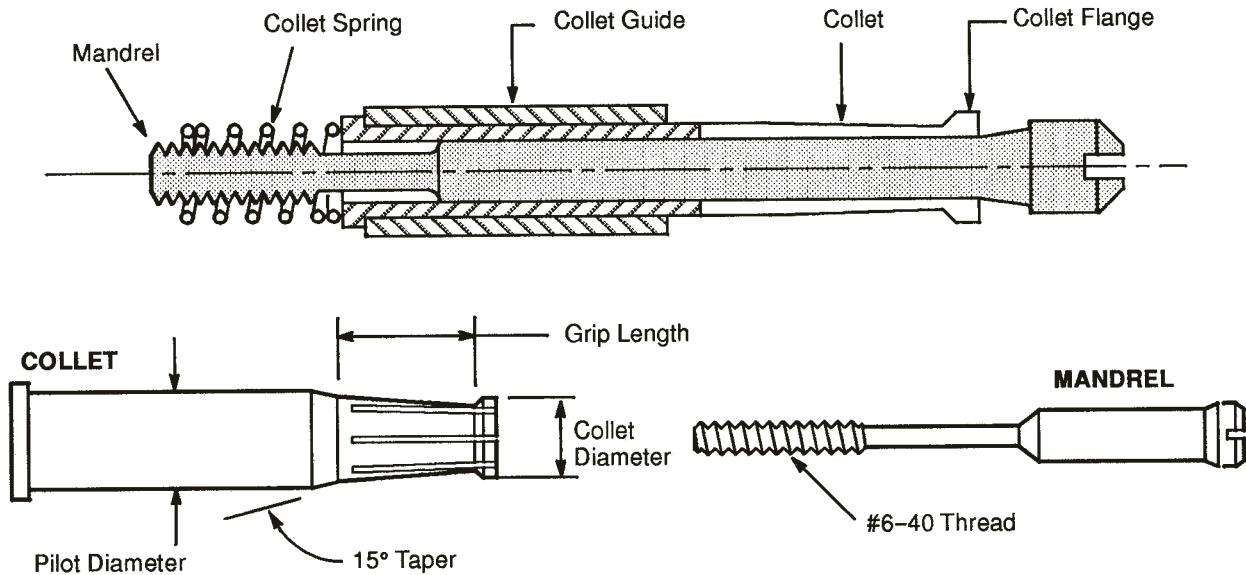

Grip Range*	Length Code**	Base Collet Number	Collet Overall Length	Base Mandrel Number	Mandrel Overall Length
0 - 0.52	- 40	46-000-xxx	1.95	46-100-xxx	2.75
0.27 - 0.77	- 63	46-001-xxx	2.20	46-101-xxx	3.00
0.52 - 1.02	- 90	46-002-xxx	2.45	46-102-xxx	3.25
0.77 - 1.27	- 115	46-003-xxx	2.70	46-103-xxx	3.50
1.02 - 1.52	- 140	46-004-xxx	2.95	46-104-xxx	3.75
1.27 - 1.77	- 163	46-005-xxx	3.18	46-105-xxx	4.00
1.52 - 2.02	- 190	46-006-xxx	3.45	46-106-xxx	4.25
1.77 - 2.27	- 215	46-007-xxx	3.70	46-107-xxx	4.50
2.02 - 2.52	- 240	46-008-xxx	3.95	46-108-xxx	4.75
2.27 - 2.77	- 263	46-009-xxx	4.18	46-109-xxx	5.00
2.52 - 3.02	- 290	46-010-xxx	4.45	46-110-xxx	5.25

#### P3 Collet Grip Chart

\* NOTE: Material thickness or stack

\*\* NOTE: The Collet Code is an old numbering system still used by many customers. It is provided for reference.

1. Determine the maximum material thickness for the application. Select the Base Collet Number and Base Mandrel Number from the chart Above. NOTE: Chart data assumes a Template Boss projection of 0.10" on a flat surface. Contoured surfaces will require longer Collets/Mandrels. For a shorter Boss, the Grip Range will be greater; for a longer Boss, the Grip Range will be lesser.

2. Refer to the following pages. Use the hole size and determine the complete Collet and Mandrel number. There is some overlap in the diameter range. If the hole size is in the overlap, use the smaller size. NOTE: A given mandrel works with three Collet sizes.

## Doler P3 Collets and Mandrels

Min. Hole Size	Max. Hole Size	Collet Code	Collet Number	Mandrel Number
----------------	----------------	-------------	---------------	----------------

### Collets and Mandrels for P3 Series

0.1550	0.1620	.1562-40	46-000-156	46-100-156
0.1550	0.1620	.1562-63	46-001-156	46-101-156
0.1550	0.1620	.1562-90	46-002-156	46-102-156
0.1550	0.1620	.1562-115	46-003-156	46-103-156
0.1550	0.1620	.1562-140	46-004-156	46-104-156
0.1550	0.1620	.1562-163	46-005-156	46-105-156
0.1550	0.1620	.1562-190	46-006-156	46-106-156
0.1600	0.1670	.1614-40	46-000-161	46-100-156
0.1600	0.1670	.1614-63	46-001-161	46-101-156
0.1600	0.1670	.1614-90	46-002-161	46-102-156
0.1600	0.1670	.1614-115	46-003-161	46-103-156
0.1600	0.1670	.1614-140	46-004-161	46-104-156
0.1600	0.1670	.1614-163	46-005-161	46-105-156
0.1600	0.1670	.1614-190	46-006-161	46-106-156
0.1655	0.1735	.1667-40	46-000-166	46-100-172
0.1655	0.1735	.1667-63	46-001-166	46-101-172
0.1655	0.1735	.1667-90	46-002-166	46-102-172
0.1655	0.1735	.1667-115	46-003-166	46-103-172
0.1655	0.1735	.1667-140	46-004-166	46-104-172
0.1655	0.1735	.1667-163	46-005-166	46-105-172
0.1655	0.1735	.1667-190	46-006-166	46-106-172
0.1710	0.1790	.1719-40	46-000-172	46-100-172
0.1710	0.1790	.1719-63	46-001-172	46-101-172
0.1710	0.1790	.1719-90	46-002-172	46-102-172
0.1710	0.1790	.1719-115	46-003-172	46-103-172
0.1710	0.1790	.1719-140	46-004-172	46-104-172
0.1710	0.1790	.1719-163	46-005-172	46-105-172
0.1710	0.1790	.1719-190	46-006-172	46-106-172
0.1765	0.1845	.1771-40	46-000-177	46-100-172
0.1765	0.1845	.1771-63	46-001-177	46-101-172
0.1765	0.1845	.1771-90	46-002-177	46-102-172
0.1765	0.1845	.1771-115	46-003-177	46-103-172
0.1765	0.1845	.1771-140	46-004-177	46-104-172
0.1765	0.1845	.1771-163	46-005-177	46-105-172
0.1765	0.1845	.1771-190	46-006-177	46-106-172
0.1815	0.1895	.1823-40	46-000-182	46-100-187
0.1815	0.1895	.1823-63	46-001-182	46-101-187
0.1815	0.1895	.1823-90	46-002-182	46-102-187
0.1815	0.1895	.1823-115	46-003-182	46-103-187
0.1815	0.1895	.1823-140	46-004-182	46-104-187
0.1815	0.1895	.1823-163	46-005-182	46-105-187
0.1815	0.1895	.1823-190	46-006-182	46-106-187
0.1865	0.1945	.1875-40	46-000-187	46-100-187
0.1865	0.1945	.1875-63	46-001-187	46-101-187
0.1865	0.1945	.1875-90	46-002-187	46-102-187
0.1865	0.1945	.1875-115	46-003-187	46-103-187
0.1865	0.1945	.1875-140	46-004-187	46-104-187
0.1865	0.1945	.1875-163	46-005-187	46-105-187
0.1865	0.1945	.1875-190	46-006-187	46-106-187
0.1865	0.1945	.1875-215	46-007-187	46-107-187

Min. Hole Size	Max. Hole Size	Collet Code	Collet Number	Mandrel Number
----------------	----------------	-------------	---------------	----------------

### Collets and Mandrels for P3 Series

0.1915	0.1995	.1927-40	46-000-192	46-100-187
0.1915	0.1995	.1927-63	46-001-192	46-101-187
0.1915	0.1995	.1927-90	46-002-192	46-102-187
0.1915	0.1995	.1927-115	46-003-192	46-103-187
0.1915	0.1995	.1927-140	46-004-192	46-104-187
0.1915	0.1995	.1927-163	46-005-192	46-105-187
0.1915	0.1995	.1927-190	46-006-192	46-106-187
0.1915	0.1995	.1927-215	46-007-192	46-107-187
0.1970	0.2050	.1979-40	46-000-197	46-100-203
0.1970	0.2050	.1979-63	46-001-197	46-101-203
0.1970	0.2050	.1979-90	46-002-197	46-102-203
0.1970	0.2050	.1979-115	46-003-197	46-103-203
0.1970	0.2050	.1979-140	46-004-197	46-104-203
0.1970	0.2050	.1979-163	46-005-197	46-105-203
0.1970	0.2050	.1979-190	46-006-197	46-106-203
0.1970	0.2050	.1979-215	46-007-197	46-107-203
0.2025	0.2105	.2031-40	46-000-203	46-100-203
0.2025	0.2105	.2031-63	46-001-203	46-101-203
0.2025	0.2105	.2031-90	46-002-203	46-102-203
0.2025	0.2105	.2031-115	46-003-203	46-103-203
0.2025	0.2105	.2031-140	46-004-203	46-104-203
0.2025	0.2105	.2031-163	46-005-203	46-105-203
0.2025	0.2105	.2031-190	46-006-203	46-106-203
0.2025	0.2105	.2031-215	46-007-203	46-107-203
0.2075	0.2155	.2083-40	46-000-208	46-100-203
0.2075	0.2155	.2083-63	46-001-208	46-101-203
0.2075	0.2155	.2083-90	46-002-208	46-102-203
0.2075	0.2155	.2083-115	46-003-208	46-103-203
0.2075	0.2155	.2083-140	46-004-208	46-104-203
0.2075	0.2155	.2083-163	46-005-208	46-105-203
0.2075	0.2155	.2083-190	46-006-208	46-106-203
0.2075	0.2155	.2083-215	46-007-208	46-107-203
0.2125	0.2205	.2135-40	46-000-213	46-100-219
0.2125	0.2205	.2135-63	46-001-213	46-101-219
0.2125	0.2205	.2135-90	46-002-213	46-102-219
0.2125	0.2205	.2135-115	46-003-213	46-103-219
0.2125	0.2205	.2135-140	46-004-213	46-104-219
0.2125	0.2205	.2135-163	46-005-213	46-105-219
0.2125	0.2205	.2135-190	46-006-213	46-106-219
0.2125	0.2205	.2135-215	46-007-213	46-107-219
0.2175	0.2255	.2188-40	46-000-219	46-100-219
0.2175	0.2255	.2188-63	46-001-219	46-101-219
0.2175	0.2255	.2188-90	46-002-219	46-102-219
0.2175	0.2255	.2188-115	46-003-219	46-103-219
0.2175	0.2255	.2188-140	46-004-219	46-104-219
0.2175	0.2255	.2188-163	46-005-219	46-105-219
0.2175	0.2255	.2188-190	46-006-219	46-106-219
0.2175	0.2255	.2188-215	46-007-219	46-107-219
0.2175	0.2255	.2188-240	46-008-219	46-108-219

Continued on Page 4-22



Min. Hole Size	Max. Hole Size	Collet Code	Collet Number	Mandrel Number
----------------	----------------	-------------	---------------	----------------

### Collets and Mandrels for P3 Series (continued)

0.2235	0.2315	.2240-40	46-000-224	46-100-219
0.2235	0.2315	.2240-63	46-001-224	46-101-219
0.2235	0.2315	.2240-90	46-002-224	46-102-219
0.2235	0.2315	.2240-115	46-003-224	46-103-219
0.2235	0.2315	.2240-140	46-004-224	46-104-219
0.2235	0.2315	.2240-163	46-005-224	46-105-219
0.2235	0.2315	.2240-190	46-006-224	46-106-219
0.2235	0.2315	.2240-215	46-007-224	46-107-219
0.2235	0.2315	.2240-240	46-008-224	46-108-219
0.2285	0.2365	.2292-40	46-000-229	46-100-234
0.2285	0.2365	.2292-63	46-001-229	46-101-234
0.2285	0.2365	.2292-90	46-002-229	46-102-234
0.2285	0.2365	.2292-115	46-003-229	46-103-234
0.2285	0.2365	.2292-140	46-004-229	46-104-234
0.2285	0.2365	.2292-163	46-005-229	46-105-234
0.2285	0.2365	.2292-190	46-006-229	46-106-234
0.2285	0.2365	.2292-215	46-007-229	46-107-234
0.2285	0.2365	.2292-240	46-008-229	46-108-234
0.2335	0.2415	.2344-40	46-000-234	46-100-234
0.2335	0.2415	.2344-63	46-001-234	46-101-234
0.2335	0.2415	.2344-90	46-002-234	46-102-234
0.2335	0.2415	.2344-115	46-003-234	46-103-234
0.2335	0.2415	.2344-140	46-004-234	46-104-234
0.2335	0.2415	.2344-163	46-005-234	46-105-234
0.2335	0.2415	.2344-190	46-006-234	46-106-234
0.2335	0.2415	.2344-215	46-007-234	46-107-234
0.2335	0.2415	.2344-240	46-008-234	46-108-234
0.2385	0.2465	.2396-40	46-000-239	46-100-234
0.2385	0.2465	.2396-63	46-001-239	46-101-234
0.2385	0.2465	.2396-90	46-002-239	46-102-234
0.2385	0.2465	.2396-115	46-003-239	46-103-234
0.2385	0.2465	.2396-140	46-004-239	46-104-234
0.2385	0.2465	.2396-163	46-005-239	46-105-234
0.2385	0.2465	.2396-190	46-006-239	46-106-234
0.2385	0.2465	.2396-215	46-007-239	46-107-234
0.2385	0.2465	.2396-240	46-008-239	46-108-234
0.2385	0.2465	.2396-263	46-009-239	46-109-234
0.2435	0.2515	.2448-40	46-000-245	46-100-250
0.2435	0.2515	.2448-63	46-001-245	46-101-250
0.2435	0.2515	.2448-90	46-002-245	46-102-250
0.2435	0.2515	.2448-115	46-003-245	46-103-250
0.2435	0.2515	.2448-140	46-004-245	46-104-250
0.2435	0.2515	.2448-163	46-005-245	46-105-250
0.2435	0.2515	.2448-190	46-006-245	46-106-250
0.2435	0.2515	.2448-215	46-007-245	46-107-250
0.2435	0.2515	.2448-240	46-008-245	46-108-250
0.2435	0.2515	.2448-263	46-009-245	46-109-250
0.2485	0.2565	.2500-40	46-000-250	46-100-250
0.2485	0.2565	.2500-63	46-001-250	46-101-250
0.2485	0.2565	.2500-90	46-002-250	46-102-250

Min. Hole Size	Max. Hole Size	Collet Code	Collet Number	Mandrel Number
----------------	----------------	-------------	---------------	----------------

### Collets and Mandrels for P3 Series (continued)

0.2485	0.2565	.2500-115	46-003-250	46-103-250
0.2485	0.2565	.2500-140	46-004-250	46-104-250
0.2485	0.2565	.2500-163	46-005-250	46-105-250
0.2485	0.2565	.2500-190	46-006-250	46-106-250
0.2485	0.2565	.2500-215	46-007-250	46-107-250
0.2485	0.2565	.2500-240	46-008-250	46-108-250
0.2485	0.2565	.2500-263	46-009-250	46-109-250
0.2545	0.2625	.2552-40	46-000-255	46-100-250
0.2545	0.2625	.2552-63	46-001-255	46-101-250
0.2545	0.2625	.2552-90	46-002-255	46-102-250
0.2545	0.2625	.2552-115	46-003-255	46-103-250
0.2545	0.2625	.2552-140	46-004-255	46-104-250
0.2545	0.2625	.2552-163	46-005-255	46-105-250
0.2545	0.2625	.2552-190	46-006-255	46-106-250
0.2545	0.2625	.2552-215	46-007-255	46-107-250
0.2545	0.2625	.2552-240	46-008-255	46-108-250
0.2545	0.2625	.2552-263	46-009-255	46-109-250
0.2595	0.2675	.2604-40	46-000-260	46-100-265
0.2595	0.2675	.2604-63	46-001-260	46-101-265
0.2595	0.2675	.2604-90	46-002-260	46-102-265
0.2595	0.2675	.2604-115	46-003-260	46-103-265
0.2595	0.2675	.2604-140	46-004-260	46-104-265
0.2595	0.2675	.2604-163	46-005-260	46-105-265
0.2595	0.2675	.2604-190	46-006-260	46-106-265
0.2595	0.2675	.2604-215	46-007-260	46-107-265
0.2595	0.2675	.2604-240	46-008-260	46-108-265
0.2595	0.2675	.2604-263	46-009-260	46-109-265
0.2645	0.2725	.2656-40	46-000-265	46-100-265
0.2645	0.2725	.2656-63	46-001-265	46-101-265
0.2645	0.2725	.2656-90	46-002-265	46-102-265
0.2645	0.2725	.2656-115	46-003-265	46-103-265
0.2645	0.2725	.2656-140	46-004-265	46-104-265
0.2645	0.2725	.2656-163	46-005-265	46-105-265
0.2645	0.2725	.2656-190	46-006-265	46-106-265
0.2645	0.2725	.2656-215	46-007-265	46-107-265
0.2645	0.2725	.2656-240	46-008-265	46-108-265
0.2645	0.2725	.2656-263	46-009-265	46-109-265
0.2645	0.2725	.2656-290	46-010-265	46-110-265
0.2695	0.2775	.2708-40	46-000-271	46-100-265
0.2695	0.2775	.2708-63	46-001-271	46-101-265
0.2695	0.2775	.2708-90	46-002-271	46-102-265
0.2695	0.2775	.2708-115	46-003-271	46-103-265
0.2695	0.2775	.2708-140	46-004-271	46-104-265
0.2695	0.2775	.2708-163	46-005-271	46-105-265
0.2695	0.2775	.2708-190	46-006-271	46-106-265
0.2695	0.2775	.2708-215	46-007-271	46-107-265
0.2695	0.2775	.2708-240	46-008-271	46-108-265
0.2695	0.2775	.2708-263	46-009-271	46-109-265
0.2695	0.2775	.2708-290	46-010-271	46-110-265

Continued on Page 4-23

## Doler P3 Collets and Mandrels

Min. Hole Size	Max. Hole Size	Collet Code	Collet Number	Mandrel Number
----------------	----------------	-------------	---------------	----------------

### Collets and Mandrels for P3 Series (continued)

0.2745	0.2825	.2760-40	46-000-276	46-100-281
0.2745	0.2825	.2760-63	46-001-276	46-101-281
0.2745	0.2825	.2760-90	46-002-276	46-102-281
0.2745	0.2825	.2760-115	46-003-276	46-103-281
0.2745	0.2825	.2760-140	46-004-276	46-104-281
0.2745	0.2825	.2760-163	46-005-276	46-105-281
0.2745	0.2825	.2760-190	46-006-276	46-106-281
0.2745	0.2825	.2760-215	46-007-276	46-107-281
0.2745	0.2825	.2760-240	46-008-276	46-108-281
0.2745	0.2825	.2760-263	46-009-276	46-109-281
0.2745	0.2825	.2760-290	46-010-276	46-110-281
0.2805	0.2885	.2812-40	46-000-281	46-100-281
0.2805	0.2885	.2812-63	46-001-281	46-101-281
0.2805	0.2885	.2812-90	46-002-281	46-102-281
0.2805	0.2885	.2812-115	46-003-281	46-103-281
0.2805	0.2885	.2812-140	46-004-281	46-104-281
0.2805	0.2885	.2812-163	46-005-281	46-105-281
0.2805	0.2885	.2812-190	46-006-281	46-106-281
0.2805	0.2885	.2812-215	46-007-281	46-107-281
0.2805	0.2885	.2812-240	46-008-281	46-108-281
0.2805	0.2885	.2812-263	46-009-281	46-109-281
0.2805	0.2885	.2812-290	46-010-281	46-110-281
0.2855	0.2935	.2864-40	46-000-286	46-100-281
0.2855	0.2935	.2864-63	46-001-286	46-101-281
0.2855	0.2935	.2864-90	46-002-286	46-102-281
0.2855	0.2935	.2864-115	46-003-286	46-103-281
0.2855	0.2935	.2864-140	46-004-286	46-104-281
0.2855	0.2935	.2864-163	46-005-286	46-105-281
0.2855	0.2935	.2864-190	46-006-286	46-106-281
0.2855	0.2935	.2864-215	46-007-286	46-107-281
0.2855	0.2935	.2864-240	46-008-286	46-108-281
0.2855	0.2935	.2864-263	46-009-286	46-109-281
0.2855	0.2935	.2864-290	46-010-286	46-110-281
0.2905	0.2985	.2916-40	46-000-291	46-100-297
0.2905	0.2985	.2916-63	46-001-291	46-101-297
0.2905	0.2985	.2916-90	46-002-291	46-102-297
0.2905	0.2985	.2916-115	46-003-291	46-103-297
0.2905	0.2985	.2916-140	46-004-291	46-104-297
0.2905	0.2985	.2916-163	46-005-291	46-105-297
0.2905	0.2985	.2916-190	46-006-291	46-106-297
0.2905	0.2985	.2916-215	46-007-291	46-107-297
0.2905	0.2985	.2916-240	46-008-291	46-108-297
0.2905	0.2985	.2916-263	46-009-291	46-109-297
0.2905	0.2985	.2916-290	46-010-291	46-110-297
0.2955	0.3035	.2969-40	46-000-297	46-100-297
0.2955	0.3035	.2969-63	46-001-297	46-101-297
0.2955	0.3035	.2969-90	46-002-297	46-102-297
0.2955	0.3035	.2969-115	46-003-297	46-103-297
0.2955	0.3035	.2969-140	46-004-297	46-104-297
0.2955	0.3035	.2969-163	46-005-297	46-105-297

Min. Hole Size	Max. Hole Size	Collet Code	Collet Number	Mandrel Number
----------------	----------------	-------------	---------------	----------------

### Collets and Mandrels for P3 Series (continued)

0.2955	0.3035	.2969-190	46-006-297	46-106-297
0.2955	0.3035	.2969-215	46-007-297	46-107-297
0.2955	0.3035	.2969-240	46-008-297	46-108-297
0.2955	0.3035	.2969-263	46-009-297	46-109-297
0.2955	0.3035	.2969-290	46-010-297	46-110-297
0.3015	0.3095	.3021-40	46-000-302	46-100-297
0.3015	0.3095	.3021-63	46-001-302	46-101-297
0.3015	0.3095	.3021-90	46-002-302	46-102-297
0.3015	0.3095	.3021-115	46-003-302	46-103-297
0.3015	0.3095	.3021-140	46-004-302	46-104-297
0.3015	0.3095	.3021-163	46-005-302	46-105-297
0.3015	0.3095	.3021-190	46-006-302	46-106-297
0.3015	0.3095	.3021-215	46-007-302	46-107-297
0.3015	0.3095	.3021-240	46-008-302	46-108-297
0.3015	0.3095	.3021-263	46-009-302	46-109-297
0.3015	0.3095	.3021-290	46-010-302	46-110-297
0.3065	0.3145	.3073-40	46-000-307	46-100-312
0.3065	0.3145	.3073-63	46-001-307	46-101-312
0.3065	0.3145	.3073-90	46-002-307	46-102-312
0.3065	0.3145	.3073-115	46-003-307	46-103-312
0.3065	0.3145	.3073-140	46-004-307	46-104-312
0.3065	0.3145	.3073-163	46-005-307	46-105-312
0.3065	0.3145	.3073-190	46-006-307	46-106-312
0.3065	0.3145	.3073-215	46-007-307	46-107-312
0.3065	0.3145	.3073-240	46-008-307	46-108-312
0.3065	0.3145	.3073-263	46-009-307	46-109-312
0.3065	0.3145	.3073-290	46-010-307	46-110-312
0.3115	0.3195	.3125-40	46-000-312	46-100-312
0.3115	0.3195	.3125-63	46-001-312	46-101-312
0.3115	0.3195	.3125-90	46-002-312	46-102-312
0.3115	0.3195	.3125-115	46-003-312	46-103-312
0.3115	0.3195	.3125-140	46-004-312	46-104-312
0.3115	0.3195	.3125-163	46-005-312	46-105-312
0.3115	0.3195	.3125-190	46-006-312	46-106-312
0.3115	0.3195	.3125-215	46-007-312	46-107-312
0.3115	0.3195	.3125-240	46-008-312	46-108-312
0.3115	0.3195	.3125-263	46-009-312	46-109-312
0.3115	0.3195	.3125-290	46-010-312	46-110-312
0.3165	0.3245	.3177-40	46-000-317	46-100-312
0.3165	0.3245	.3177-63	46-001-317	46-101-312
0.3165	0.3245	.3177-90	46-002-317	46-102-312
0.3165	0.3245	.3177-115	46-003-317	46-103-312
0.3165	0.3245	.3177-140	46-004-317	46-104-312
0.3165	0.3245	.3177-163	46-005-317	46-105-312
0.3165	0.3245	.3177-190	46-006-317	46-106-312
0.3165	0.3245	.3177-215	46-007-317	46-107-312
0.3165	0.3245	.3177-240	46-008-317	46-108-312
0.3165	0.3245	.3177-263	46-009-317	46-109-312
0.3165	0.3245	.3177-290	46-010-317	46-110-312

Continued on Page 4-24





Min. Hole Size	Max. Hole Size	Collet Code	Collet Number	Mandrel Number
----------------	----------------	-------------	---------------	----------------

### Collets and Mandrels for P3 Series (continued)

0.3215	0.3295	.3229-40	46-000-323	46-100-328
0.3215	0.3295	.3229-63	46-001-323	46-101-328
0.3215	0.3295	.3229-90	46-002-323	46-102-328
0.3215	0.3295	.3229-115	46-003-323	46-103-328
0.3215	0.3295	.3229-140	46-004-323	46-104-328
0.3215	0.3295	.3229-163	46-005-323	46-105-328
0.3215	0.3295	.3229-190	46-006-323	46-106-328
0.3215	0.3295	.3229-215	46-007-323	46-107-328
0.3215	0.3295	.3229-240	46-008-323	46-108-328
0.3215	0.3295	.3229-263	46-009-323	46-109-328
0.3215	0.3295	.3229-290	46-010-323	46-110-328
0.3275	0.3355	.3281-40	46-000-328	46-100-328
0.3275	0.3355	.3281-63	46-001-328	46-101-328
0.3275	0.3355	.3281-90	46-002-328	46-102-328
0.3275	0.3355	.3281-115	46-003-328	46-103-328
0.3275	0.3355	.3281-140	46-004-328	46-104-328
0.3275	0.3355	.3281-163	46-005-328	46-105-328
0.3275	0.3355	.3281-190	46-006-328	46-106-328
0.3275	0.3355	.3281-215	46-007-328	46-107-328
0.3275	0.3355	.3281-240	46-008-328	46-108-328
0.3275	0.3355	.3281-263	46-009-328	46-109-328
0.3275	0.3355	.3281-290	46-010-328	46-110-328
0.3325	0.3405	.3333-40	46-000-333	46-100-328
0.3325	0.3405	.3333-63	46-001-333	46-101-328
0.3325	0.3405	.3333-90	46-002-333	46-102-328
0.3325	0.3405	.3333-115	46-003-333	46-103-328
0.3325	0.3405	.3333-140	46-004-333	46-104-328
0.3325	0.3405	.3333-163	46-005-333	46-105-328
0.3325	0.3405	.3333-190	46-006-333	46-106-328
0.3325	0.3405	.3333-215	46-007-333	46-107-328
0.3325	0.3405	.3333-240	46-008-333	46-108-328
0.3325	0.3405	.3333-263	46-009-333	46-109-328
0.3325	0.3405	.3333-290	46-010-333	46-110-328
0.3375	0.3455	.3385-40	46-000-338	46-100-344
0.3375	0.3455	.3385-63	46-001-338	46-101-344
0.3375	0.3455	.3385-90	46-002-338	46-102-344
0.3375	0.3455	.3385-115	46-003-338	46-103-344
0.3375	0.3455	.3385-140	46-004-338	46-104-344
0.3375	0.3455	.3385-163	46-005-338	46-105-344
0.3375	0.3455	.3385-190	46-006-338	46-106-344
0.3375	0.3455	.3385-215	46-007-338	46-107-344
0.3375	0.3455	.3385-240	46-008-338	46-108-344
0.3375	0.3455	.3385-263	46-009-338	46-109-344
0.3375	0.3455	.3385-290	46-010-338	46-110-344
0.3425	0.3505	.3438-40	46-000-344	46-100-344
0.3425	0.3505	.3438-63	46-001-344	46-101-344
0.3425	0.3505	.3438-90	46-002-344	46-102-344
0.3425	0.3505	.3438-115	46-003-344	46-103-344
0.3425	0.3505	.3438-140	46-004-344	46-104-344
0.3425	0.3505	.3438-163	46-005-344	46-105-344

Min. Hole Size	Max. Hole Size	Collet Code	Collet Number	Mandrel Number
----------------	----------------	-------------	---------------	----------------

### Collets and Mandrels for P3 Series (continued)

0.3425	0.3505	.3438-190	46-006-344	46-106-344
0.3425	0.3505	.3438-215	46-007-344	46-107-344
0.3425	0.3505	.3438-240	46-008-344	46-108-344
0.3425	0.3505	.3438-263	46-009-344	46-109-344
0.3425	0.3505	.3438-290	46-010-344	46-110-344
0.3475	0.3555	.3490-40	46-000-349	46-100-344
0.3475	0.3555	.3490-63	46-001-349	46-101-344
0.3475	0.3555	.3490-90	46-002-349	46-102-344
0.3475	0.3555	.3490-115	46-003-349	46-103-344
0.3475	0.3555	.3490-140	46-004-349	46-104-344
0.3475	0.3555	.3490-163	46-005-349	46-105-344
0.3475	0.3555	.3490-190	46-006-349	46-106-344
0.3475	0.3555	.3490-215	46-007-349	46-107-344
0.3475	0.3555	.3490-240	46-008-349	46-108-344
0.3475	0.3555	.3490-263	46-009-349	46-109-344
0.3475	0.3555	.3490-290	46-010-349	46-110-344
0.3535	0.3615	.3542-40	46-000-354	46-100-359
0.3535	0.3615	.3542-63	46-001-354	46-101-359
0.3535	0.3615	.3542-90	46-002-354	46-102-359
0.3535	0.3615	.3542-115	46-003-354	46-103-359
0.3535	0.3615	.3542-140	46-004-354	46-104-359
0.3535	0.3615	.3542-163	46-005-354	46-105-359
0.3535	0.3615	.3542-190	46-006-354	46-106-359
0.3535	0.3615	.3542-215	46-007-354	46-107-359
0.3535	0.3615	.3542-240	46-008-354	46-108-359
0.3535	0.3615	.3542-263	46-009-354	46-109-359
0.3535	0.3615	.3542-290	46-010-354	46-110-359
0.3585	0.3665	.3594-40	46-000-359	46-100-359
0.3585	0.3665	.3594-63	46-001-359	46-101-359
0.3585	0.3665	.3594-90	46-002-359	46-102-359
0.3585	0.3665	.3594-115	46-003-359	46-103-359
0.3585	0.3665	.3594-140	46-004-359	46-104-359
0.3585	0.3665	.3594-163	46-005-359	46-105-359
0.3585	0.3665	.3594-190	46-006-359	46-106-359
0.3585	0.3665	.3594-215	46-007-359	46-107-359
0.3585	0.3665	.3594-240	46-008-359	46-108-359
0.3585	0.3665	.3594-263	46-009-359	46-109-359
0.3585	0.3665	.3594-290	46-010-359	46-110-359
0.3635	0.3715	.3646-40	46-000-364	46-100-364
0.3635	0.3715	.3646-63	46-001-364	46-101-364
0.3635	0.3715	.3646-90	46-002-364	46-102-364
0.3635	0.3715	.3646-115	46-003-364	46-103-364
0.3635	0.3715	.3646-140	46-004-364	46-104-364
0.3635	0.3715	.3646-163	46-005-364	46-105-364
0.3635	0.3715	.3646-190	46-006-364	46-106-364
0.3635	0.3715	.3646-215	46-007-364	46-107-364
0.3635	0.3715	.3646-240	46-008-364	46-108-364
0.3635	0.3715	.3646-263	46-009-364	46-109-364
0.3635	0.3715	.3646-290	46-010-364	46-110-364

Continued on Page 4-25

## Doler P3 Collets and Mandrels

Min. Hole Size	Max. Hole Size	Collet Code	Collet Number	Mandrel Number
----------------	----------------	-------------	---------------	----------------

### Collets and Mandrels for P3 Series (continued)

0.3685	0.3765	.3698-40	46-000-370	46-100-375
0.3685	0.3765	.3698-63	46-001-370	46-101-375
0.3685	0.3765	.3698-90	46-002-370	46-102-375
0.3685	0.3765	.3698-115	46-003-370	46-103-375
0.3685	0.3765	.3698-140	46-004-370	46-104-375
0.3685	0.3765	.3698-163	46-005-370	46-105-375
0.3685	0.3765	.3698-190	46-006-370	46-106-375
0.3685	0.3765	.3698-215	46-007-370	46-107-375
0.3685	0.3765	.3698-240	46-008-370	46-108-375
0.3685	0.3765	.3698-263	46-009-370	46-109-375
0.3685	0.3765	.3698-290	46-010-370	46-110-375
0.3735	0.3815	.3750-40	46-000-375	46-100-375
0.3735	0.3815	.3750-63	46-001-375	46-101-375
0.3735	0.3815	.3750-90	46-002-375	46-102-375
0.3735	0.3815	.3750-115	46-003-375	46-103-375
0.3735	0.3815	.3750-140	46-004-375	46-104-375
0.3735	0.3815	.3750-163	46-005-375	46-105-375
0.3735	0.3815	.3750-190	46-006-375	46-106-375
0.3735	0.3815	.3750-215	46-007-375	46-107-375
0.3735	0.3815	.3750-240	46-008-375	46-108-375
0.3735	0.3815	.3750-263	46-009-375	46-109-375
0.3735	0.3815	.3750-290	46-010-375	46-110-375
0.3795	0.3875	.3802-40	46-000-380	46-100-375
0.3795	0.3875	.3802-63	46-001-380	46-101-375
0.3795	0.3875	.3802-90	46-002-380	46-102-375
0.3795	0.3875	.3802-115	46-003-380	46-103-375
0.3795	0.3875	.3802-140	46-004-380	46-104-375
0.3795	0.3875	.3802-163	46-005-380	46-105-375
0.3795	0.3875	.3802-190	46-006-380	46-106-375
0.3795	0.3875	.3802-215	46-007-380	46-107-375
0.3795	0.3875	.3802-240	46-008-380	46-108-375
0.3795	0.3875	.3802-263	46-009-380	46-109-375
0.3795	0.3875	.3802-290	46-010-380	46-110-375
0.3845	0.3925	.3854-40	46-000-385	46-100-390
0.3845	0.3925	.3854-63	46-001-385	46-101-390
0.3845	0.3925	.3854-90	46-002-385	46-102-390
0.3845	0.3925	.3854-115	46-003-385	46-103-390
0.3845	0.3925	.3854-140	46-004-385	46-104-390
0.3845	0.3925	.3854-163	46-005-385	46-105-390
0.3845	0.3925	.3854-190	46-006-385	46-106-390
0.3845	0.3925	.3854-215	46-007-385	46-107-390
0.3845	0.3925	.3854-240	46-008-385	46-108-390
0.3845	0.3925	.3854-263	46-009-385	46-109-390
0.3845	0.3925	.3854-290	46-010-385	46-110-390
0.3895	0.3975	.3906-40	46-000-390	46-100-390
0.3895	0.3975	.3906-63	46-001-390	46-101-390
0.3895	0.3975	.3906-90	46-002-390	46-102-390
0.3895	0.3975	.3906-115	46-003-390	46-103-390
0.3895	0.3975	.3906-140	46-004-390	46-104-390
0.3895	0.3975	.3906-163	46-005-390	46-105-390

Min. Hole Size	Max. Hole Size	Collet Code	Collet Number	Mandrel Number
----------------	----------------	-------------	---------------	----------------

### Collets and Mandrels for P3 Series (continued)

0.3895	0.3975	.3906-190	46-006-390	46-106-390
0.3895	0.3975	.3906-215	46-007-390	46-107-390
0.3895	0.3975	.3906-240	46-008-390	46-108-390
0.3895	0.3975	.3906-263	46-009-390	46-109-390
0.3895	0.3975	.3906-290	46-010-390	46-110-390
0.3945	0.4025	.3958-40	46-000-396	46-100-390
0.3945	0.4025	.3958-63	46-001-396	46-101-390
0.3945	0.4025	.3958-90	46-002-396	46-102-390
0.3945	0.4025	.3958-115	46-003-396	46-103-390
0.3945	0.4025	.3958-140	46-004-396	46-104-390
0.3945	0.4025	.3958-163	46-005-396	46-105-390
0.3945	0.4025	.3958-190	46-006-396	46-106-390
0.3945	0.4025	.3958-215	46-007-396	46-107-390
0.3945	0.4025	.3958-240	46-008-396	46-108-390
0.3945	0.4025	.3958-263	46-009-396	46-109-390
0.3945	0.4025	.3958-290	46-010-396	46-110-390
0.3995	0.4075	.4010-40	46-000-401	46-100-406
0.3995	0.4075	.4010-63	46-001-401	46-101-406
0.3995	0.4075	.4010-90	46-002-401	46-102-406
0.3995	0.4075	.4010-115	46-003-401	46-103-406
0.3995	0.4075	.4010-140	46-004-401	46-104-406
0.3995	0.4075	.4010-163	46-005-401	46-105-406
0.3995	0.4075	.4010-190	46-006-401	46-106-406
0.3995	0.4075	.4010-215	46-007-401	46-107-406
0.3995	0.4075	.4010-240	46-008-401	46-108-406
0.3995	0.4075	.4010-263	46-009-401	46-109-406
0.3995	0.4075	.4010-290	46-010-401	46-110-406
0.4055	0.4135	.4062-40	46-000-406	46-100-406
0.4055	0.4135	.4062-63	46-001-406	46-101-406
0.4055	0.4135	.4062-90	46-002-406	46-102-406
0.4055	0.4135	.4062-115	46-003-406	46-103-406
0.4055	0.4135	.4062-140	46-004-406	46-104-406
0.4055	0.4135	.4062-163	46-005-406	46-105-406
0.4055	0.4135	.4062-190	46-006-406	46-106-406
0.4055	0.4135	.4062-215	46-007-406	46-107-406
0.4055	0.4135	.4062-240	46-008-406	46-108-406
0.4055	0.4135	.4062-263	46-009-406	46-109-406
0.4055	0.4135	.4062-290	46-010-406	46-110-406
0.4105	0.4185	.4114-40	46-000-411	46-100-406
0.4105	0.4185	.4114-63	46-001-411	46-101-406
0.4105	0.4185	.4114-90	46-002-411	46-102-406
0.4105	0.4185	.4114-115	46-003-411	46-103-406
0.4105	0.4185	.4114-140	46-004-411	46-104-406
0.4105	0.4185	.4114-163	46-005-411	46-105-406
0.4105	0.4185	.4114-190	46-006-411	46-106-406
0.4105	0.4185	.4114-215	46-007-411	46-107-406
0.4105	0.4185	.4114-240	46-008-411	46-108-406
0.4105	0.4185	.4114-263	46-009-411	46-109-406
0.4105	0.4185	.4114-290	46-010-411	46-110-406

Continued on Page 4-26



Min. Hole Size	Max. Hole Size	Collet Code	Collet Number	Mandrel Number
----------------	----------------	-------------	---------------	----------------

### Collets and Mandrels for P3 Series (continued)

0.4155	0.4235	.4166-40	46-000-417	46-100-422
0.4155	0.4235	.4166-63	46-001-417	46-101-422
0.4155	0.4235	.4166-90	46-002-417	46-102-422
0.4155	0.4235	.4166-115	46-003-417	46-103-422
0.4155	0.4235	.4166-140	46-004-417	46-104-422
0.4155	0.4235	.4166-163	46-005-417	46-105-422
0.4155	0.4235	.4166-190	46-006-417	46-106-422
0.4155	0.4235	.4166-215	46-007-417	46-107-422
0.4155	0.4235	.4166-240	46-008-417	46-108-422
0.4155	0.4235	.4166-263	46-009-417	46-109-422
0.4155	0.4235	.4166-290	46-010-417	46-110-422
0.4205	0.4285	.4219-40	46-000-422	46-100-422
0.4205	0.4285	.4219-63	46-001-422	46-101-422
0.4205	0.4285	.4219-90	46-002-422	46-102-422
0.4205	0.4285	.4219-115	46-003-422	46-103-422
0.4205	0.4285	.4219-140	46-004-422	46-104-422
0.4205	0.4285	.4219-163	46-005-422	46-105-422
0.4205	0.4285	.4219-190	46-006-422	46-106-422
0.4205	0.4285	.4219-215	46-007-422	46-107-422
0.4205	0.4285	.4219-240	46-008-422	46-108-422
0.4205	0.4285	.4219-263	46-009-422	46-109-422
0.4205	0.4285	.4219-290	46-010-422	46-110-422
0.4265	0.4345	.4271-40	46-000-427	46-100-422
0.4265	0.4345	.4271-63	46-001-427	46-101-422
0.4265	0.4345	.4271-90	46-002-427	46-102-422
0.4265	0.4345	.4271-115	46-003-427	46-103-422
0.4265	0.4345	.4271-140	46-004-427	46-104-422
0.4265	0.4345	.4271-163	46-005-427	46-105-422
0.4265	0.4345	.4271-190	46-006-427	46-106-422
0.4265	0.4345	.4271-215	46-007-427	46-107-422
0.4265	0.4345	.4271-240	46-008-427	46-108-422
0.4265	0.4345	.4271-263	46-009-427	46-109-422
0.4265	0.4345	.4271-290	46-010-427	46-110-422
0.4315	0.4395	.4323-40	46-000-432	46-100-437
0.4315	0.4395	.4323-63	46-001-432	46-101-437
0.4315	0.4395	.4323-90	46-002-432	46-102-437
0.4315	0.4395	.4323-115	46-003-432	46-103-437
0.4315	0.4395	.4323-140	46-004-432	46-104-437
0.4315	0.4395	.4323-163	46-005-432	46-105-437
0.4315	0.4395	.4323-190	46-006-432	46-106-437
0.4315	0.4395	.4323-215	46-007-432	46-107-437
0.4315	0.4395	.4323-240	46-008-432	46-108-437
0.4315	0.4395	.4323-263	46-009-432	46-109-437
0.4315	0.4395	.4323-290	46-010-432	46-110-437

Min. Hole Size	Max. Hole Size	Collet Code	Collet Number	Mandrel Number
----------------	----------------	-------------	---------------	----------------

### Collets and Mandrels for P3 Series (continued)

0.4365	0.4445	.4375-40	46-000-437	46-100-437
0.4365	0.4445	.4375-63	46-001-437	46-101-437
0.4365	0.4445	.4375-90	46-002-437	46-102-437
0.4365	0.4445	.4375-115	46-003-437	46-103-437
0.4365	0.4445	.4375-140	46-004-437	46-104-437
0.4365	0.4445	.4375-163	46-005-437	46-105-437
0.4365	0.4445	.4375-190	46-006-437	46-106-437
0.4365	0.4445	.4375-215	46-007-437	46-107-437
0.4365	0.4445	.4375-240	46-008-437	46-108-437
0.4365	0.4445	.4375-263	46-009-437	46-109-437
0.4365	0.4445	.4375-290	46-010-437	46-110-437
0.4415	0.4495	.4427-40	46-000-443	46-100-437
0.4415	0.4495	.4427-63	46-001-443	46-101-437
0.4415	0.4495	.4427-90	46-002-443	46-102-437
0.4415	0.4495	.4427-115	46-003-443	46-103-437
0.4415	0.4495	.4427-140	46-004-443	46-104-437
0.4415	0.4495	.4427-163	46-005-443	46-105-437
0.4415	0.4495	.4427-190	46-006-443	46-106-437
0.4415	0.4495	.4427-215	46-007-443	46-107-437
0.4415	0.4495	.4427-240	46-008-443	46-108-437
0.4415	0.4495	.4427-263	46-009-443	46-109-437
0.4415	0.4495	.4427-290	46-010-443	46-110-437
0.4465	0.4545	.4479-40	46-000-448	46-100-453
0.4465	0.4545	.4479-63	46-001-448	46-101-453
0.4465	0.4545	.4479-90	46-002-448	46-102-453
0.4465	0.4545	.4479-115	46-003-448	46-103-453
0.4465	0.4545	.4479-140	46-004-448	46-104-453
0.4465	0.4545	.4479-163	46-005-448	46-105-453
0.4465	0.4545	.4479-190	46-006-448	46-106-453
0.4465	0.4545	.4479-215	46-007-448	46-107-453
0.4465	0.4545	.4479-240	46-008-448	46-108-453
0.4465	0.4545	.4479-263	46-009-448	46-109-453
0.4465	0.4545	.4479-290	46-010-448	46-110-453
0.4525	0.4605	.4531-40	46-000-453	46-100-453
0.4525	0.4605	.4531-63	46-001-453	46-101-453
0.4525	0.4605	.4531-90	46-002-453	46-102-453
0.4525	0.4605	.4531-115	46-003-453	46-103-453
0.4525	0.4605	.4531-140	46-004-453	46-104-453
0.4525	0.4605	.4531-163	46-005-453	46-105-453
0.4525	0.4605	.4531-190	46-006-453	46-106-453
0.4525	0.4605	.4531-215	46-007-453	46-107-453
0.4525	0.4605	.4531-240	46-008-453	46-108-453
0.4525	0.4605	.4531-263	46-009-453	46-109-453
0.4525	0.4605	.4531-290	46-010-453	46-110-453



## QUACKENBUSH™

### 136SC-B-118 Q-Matic Self-Collecting Drill Motor

Drill Capacity: .25" (6.4mm)  
Countersink Capacity: .5"  
(12.7mm)

Feed Stroke: 1.1875"  
(30.2mm)

Clamp Stroke: .5625"  
(14.3mm)

- Motor, clamp and retract mechanism are air-operated; feed rate is controlled by metering hydraulic fluid through adjustable orifice.
- Semi-automatic self-colleting tool has automatic clamp/drill/retract cycle.
- 136 series motor develops .85 nominal horsepower.
- Optional mist lubricator introduces coolant and air blast to cutter.
- Booster pump accessory increases both clamp and feed pressures.
- Distance between collet and drill is variable from .5 in. (12.5 mm) to 2.75 in. (70 mm).
- Tool has trigger lock to allow tool to cycle without operator attention.
- Tool remains clamped to workpiece until operator releases trigger.

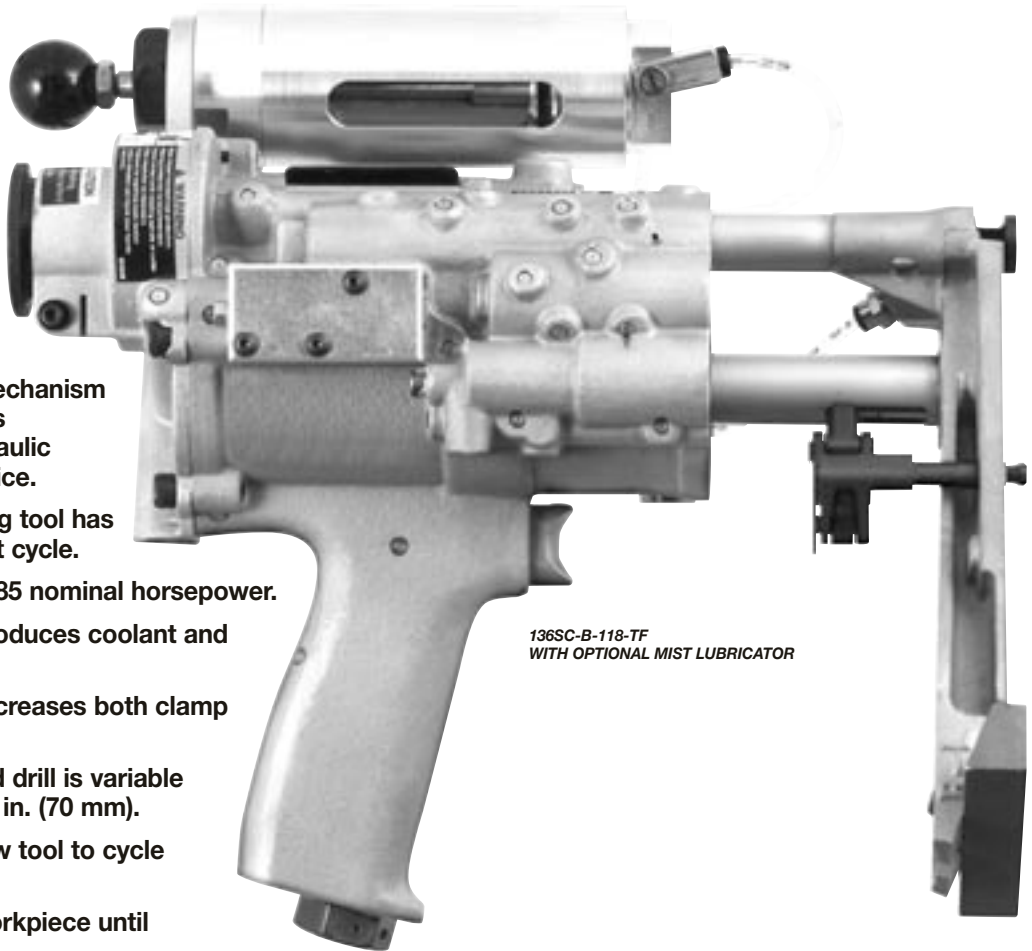

136SC-B-118-TF  
WITH OPTIONAL MIST LUBRICATOR

Model	Stroke		Feed Rate	Weight w/steel foot		Spindle Speeds (RPM)	Variable Distance Collet to Drill	Inlet	Minimum Hose Size
	Feed	Collet		lbs	kg				
136SC-B-118	1.125 in (28mm)	.5625 in (14mm)	.05 to 40 in/sec 1.25 to 10 mm/sec	7.0	3.2	400, 900, 2100, 3100, 6000, 7800, 11,500, 22,500	Min: .5 in (12.7mm) Max: 2.75 in (70mm)	.375" NPT	.5" (12.7mm)

Rated tool performance at 90 PSIG measured at toll inlet with motor running.

#### INFORMATION REQUIRED FOR ORDERING SELF-COLLECTING DRILL:

1. TOOL RPM
2. TYPE SPINDLE REQUIRED (Exact information concerning the cutter to be utilized in the drilling application must be provided in order to determine the proper spindle configuration. A drawing of the cutter should be provided for each application.)

#### 3. FOOT TYPE REQUIRED:

- Template Foot Right Hand OR Left Hand
- Jig Collet Foot Depth Sensing OR Non-Depth Sensing
- Drill Lock Bushing Foot 21000 series OR 22000 Series Bushing

#### 4. TOOLING INFORMATION

- Template Foot Models
  - Template Boss (see page 4-33)
  - Collet/Mandrel Assembly (see page 4-33)
  - Jig Collet Foot Models
- For depth sensing models, the stand-off distance (see page 4-31) must be provided.

# Quackenbush® Self Collecting Machines

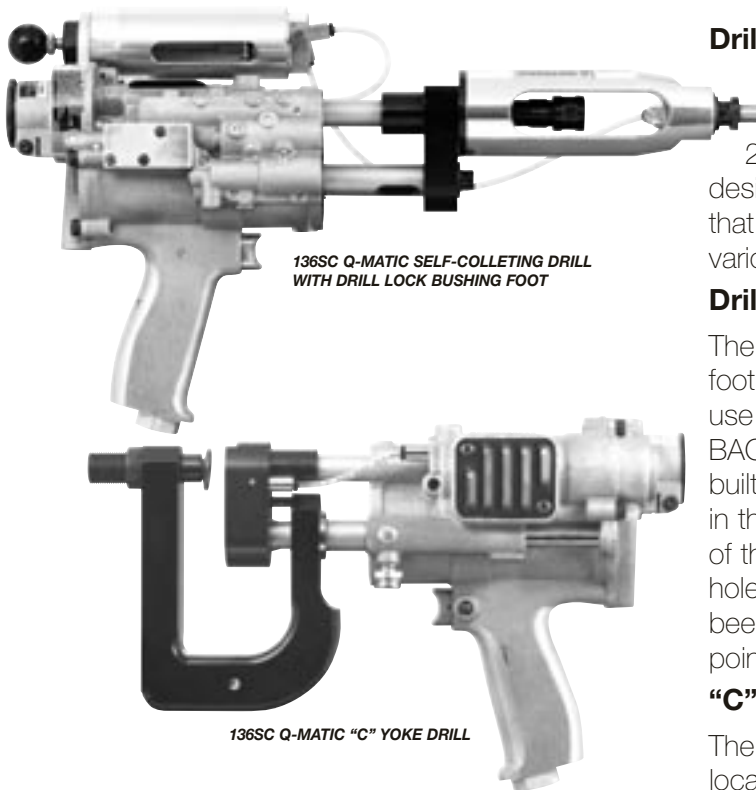
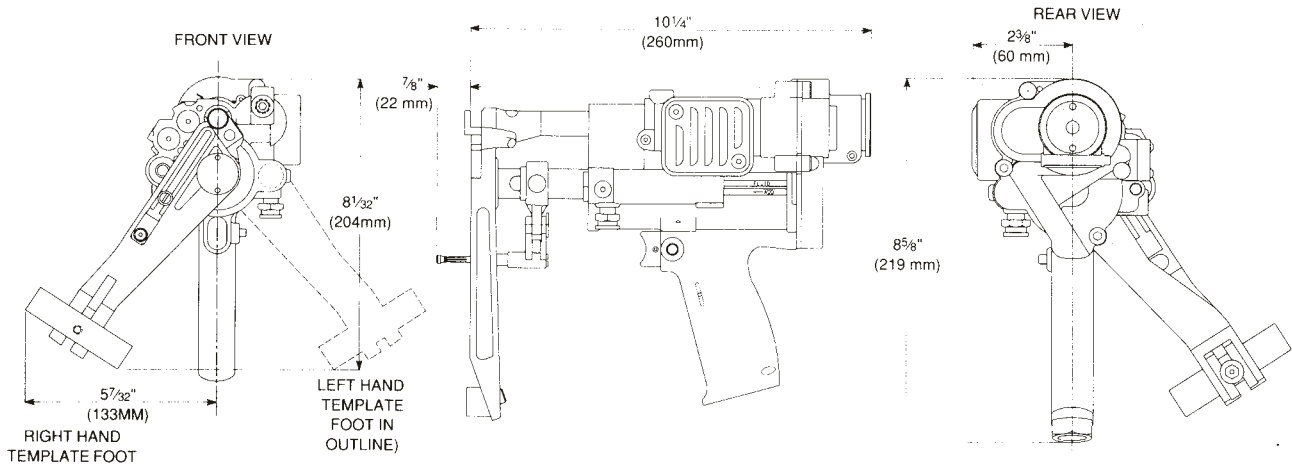

136SC Q-MATIC SELF-COLLECTING DRILL WITH DRILL LOCK BUSHING FOOT

136SC Q-MATIC "C" YOKE DRILL

## Drill Lock Bushing Foot

The versatile Q-Matic 136SC Drill is available with a foot which accepts standard 21000 and 22000 series lock-type drill bushings. This foot design increases the versatility of the Q-Matic Drill so that it may be locked onto the rigid tooling plate using various drill bushing tips and their accessories.

## Drill Jig Collet Foot

The 136SC Q-Matic Drill is available with a jig collet foot, either with or without a depth sensing sleeve, for use with rigid tooling plates which have STRAIGHT or BACK TAPERED locating holes. This attachment, with a built-in sensing sleeve, will sense variations up to .125" in the distance between the work surface and the top of the tooling plate, which allows production drilling of holes with countersink to precise limits. A port has been provided in the foot to deliver coolant to the drill point.

## "C" Yoke

The 136SC is available with a "C" Yoke for perimeter located holes.

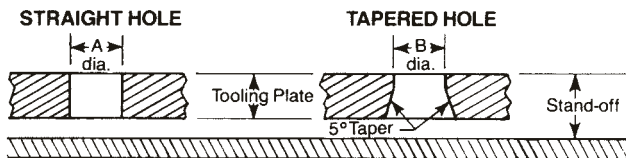

## INFORMATION REQUIRED TO ORDER JIG COLLET FOOT TOOLS:

- (1) Specify tooling plate hole size—diameter A or B—in order to determine collet size (see standard collet size chart).
- (2) When ordering depth sensing models, specify stand-off distance. (Top of tooling plate to work surface)
- (3) When ordering for straight hole tooling plates, specify tooling plate thickness.

## STANDARD COLLET SIZES

	Straight Hole A dia.	Tapered Hole B dia.
Depth Sensing	1.000 .875	.796 .670
Non-Depth Sensing	1.000 .875 .750 .625	.796 .670 .640 .500

Special collets available upon request.

## QUACKENBUSH™

### 136SC-B-118 Q-Matic Self-Collecting Drill Motor

#### Booster Pump Assembly

For increased clamping and feed force, an optional Booster Pump (Part No. 621482) is available. The pump provides extra clamp and feed when required. The Booster Pump assembly will increase both clamp and feed forces by a factor of 2.5.

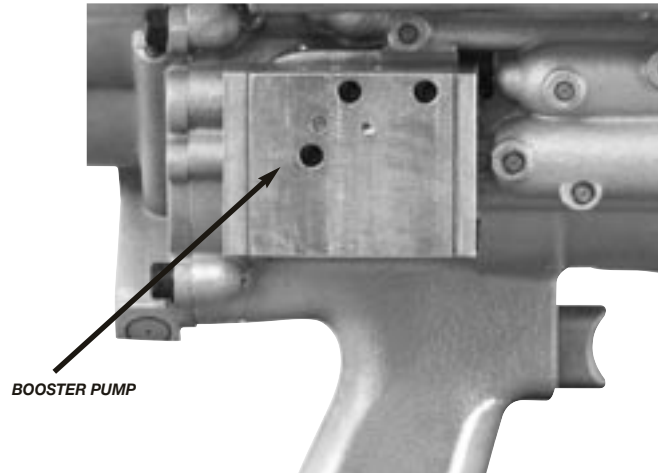

#### Mist Lubricator Assembly

A mist lubricator assembly is available to introduce coolant and air to the cutter. The lubricator is actuated by air from the accessory air tap on the motor side and only functions when the motor is running. The standard mist lubricator (Part No. 631297) can be filled with manually. Fill reservoir (622900) available for filling standard manual fill lubricator. The optional mist lubricator (Part No. 631296) is filled by a pressure pump.

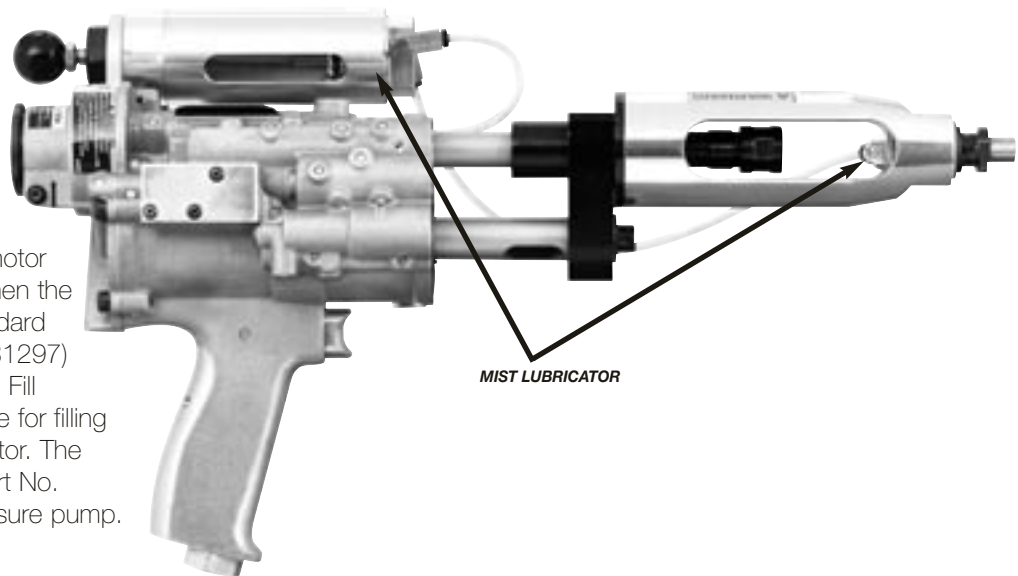

	Small	Large
Manual Fill	631297	
Pressure Fill	631296	631404

## Template Boss



**TEMPLATE BOSS**  
NOTE: TEMPLATE BOSSES ARE OPTIONAL AND ARE TO BE SPECIFIED BY CUSTOMER IF REQUIRED.

Application		Template Boss Part No.
B Template Hole Dia.	C Sink Dia.	Code No.
.434	.271	623573
.434	.286	623574
.434	.317	623575
.497	.271	623576
.497	.286	623577
.497	.317	623578
.497	.349	623579
.497	.380	623580
.622	.317	623581
.622	.349	623582
.622	.380	623583
.622	.411	623584
.622	.489	623585
.622	.505	623586

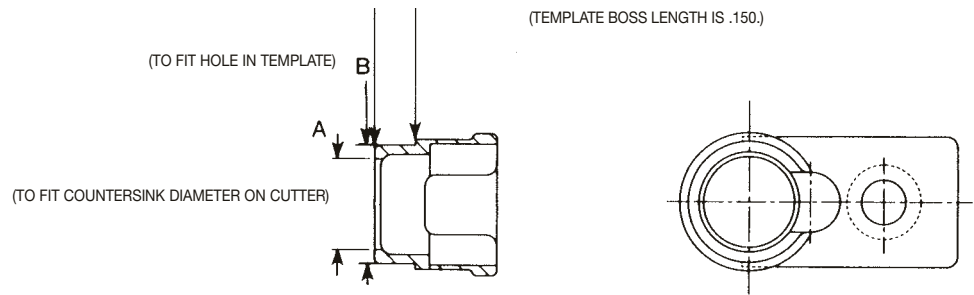

## Collets and Mandrels

Collets and Mandrels are supplied as standard equipment with each tool and must be specified when ordered.

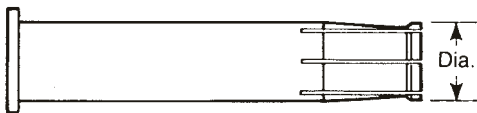

Typical Configuration of Collets for hole sizes up to .250 in.

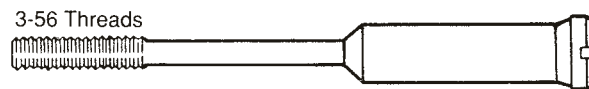

Typical Configuration of Mandrels for hole sizes up to .250 in.

### INFORMATION NECESSARY TO ORDER COLLETS AND MANDRELS HOLE SIZE AND COLLET LENGTH CODE

**EXAMPLE;** Application is to drill a .250 dia. hole in .500 thick material using a template with a thickness of .125 in. SELECT Template Boss (See Template Boss Length information above). This application requires a .150 length. Using Material Thickness Grip Range chart based on .500 material thickness, the collet and mandrel Length Code is EITHER -40 or -63

Material Thickness Grip Range	
Temp. Boss Length .150	Collet Length Code*

#### Series 1000 Standard Collets

.00 - .37	- 23
.18 - .62	- 40
.43 - .87	- 63
.68 - 1.12	- 90

**ORDER:**      250-40      or      .250-63 collet/mandrel  
                   Hole Size ↑      Collet Length Code



## QUACKENBUSH™

### 136SC-150 Q-Matic Self-Colleting Drill Motor

Drill Capacity: .25" (6.4mm)  
 Countersink Capacity: .5" (12.7mm)

Feed Stroke: 1.5" (30mm)  
 Clamp Stroke: .5625" (14.3mm)

■ Motor, clamp and retract mechanism are air-operated; feed rate is controlled by external hydraulic feed control cylinder.

■ Semi-automatic self-colleting tool has automatic clamp/drill/retract cycle.

■ 136 series motor develops .85 nominal horsepower.

■ Optional mist lubricator introduces coolant and air blast to cutter.

■ Booster pump accessory increases both clamp and feed pressures.

■ Distance between collet and drill is variable from .5 in. (12.5 mm) to 2.75 in. (70 mm).

■ Tool has trigger lock to allow tool to cycle without operator attention.

■ Tool remains clamped to workpiece until operator releases trigger.



Model	Stroke		Feed Rate	Weight w/steel foot		Spindle Speeds (RPM)	Variable Distance Collet to Drill	Inlet	Minimum Hose Size
	Feed	Collet		lbs	kg				
136SC-150	1.5 in (30mm)	.5625 in (14mm)	.05 to 40 in/sec 1.25 to 10 mm/sec	8.0	3.6	400, 900, 2100, 3100, 6000, 7800, 11,500, 22,500	Min: .5 in (12.7mm) Max. 2.75 in (70mm)	.375" NPT	.5" (12.7mm)

Rated tool performance at 90 PSIG measured at toll inlet with motor running.

**INFORMATION REQUIRED FOR ORDERING SELF-COLLECTING DRILL:**

1. TOOL RPM
2. TYPE SPINDLE REQUIRED (Exact information concerning the cutter to be utilized in the drilling application must be provided in order to determine the proper spindle configuration. A drawing of the cutter should be provided for each application.)

**3. FOOT TYPE REQUIRED:**

- Template Foot Right Hand OR Left Hand
- Jig Collet Foot Depth Sensing OR Non-Depth Sensing
- Drill Lock Bushing Foot 21000 series OR 22000 Series Bushing

**4. TOOLING INFORMATION**

- Template Foot Models
  - Template Boss (see page 4-37)
  - Collet/Mandrel Assembly (see page 4-37)
  - Jig Collet Foot Models
- For depth sensing models, the stand-off distance (see page 4-35) must be provided. Collet/Mandrel Assembly (see page 4-37)

# Quackenbush® Self Collecting Machines

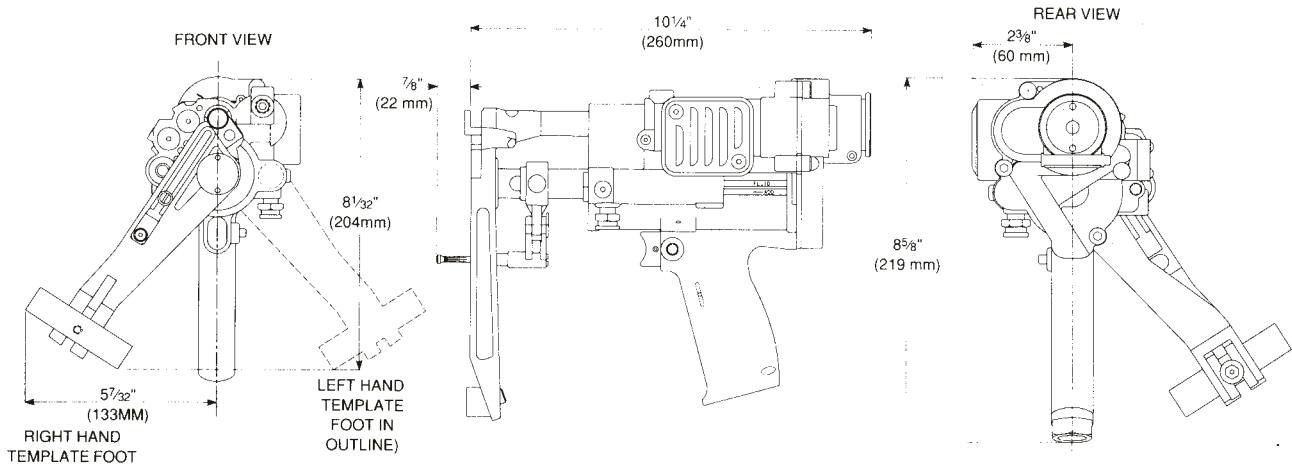

## Drill Lock Bushing Foot

The versatile Q-Matic 136SC Drill is available with a foot which accepts standard 21000 and 22000 series lock-type drill bushings. This foot design increases the versatility of the Q-Matic Drill so that it may be locked onto the rigid tooling plate using various drill bushing tips and their accessories.

## Drill Jig Collet Foot

The 136SC Q-Matic Drill is available with a jig collet foot, either with or without a depth sensing sleeve, for use with rigid tooling plates which have STRAIGHT or BACK TAPERED locating holes. This attachment, with a built-in sensing sleeve, will sense variations up to .125" in the distance between the work surface and the top of the tooling plate, which allows production drilling of holes with countersink to precise limits. A port has been provided in the foot to deliver coolant to the drill point.

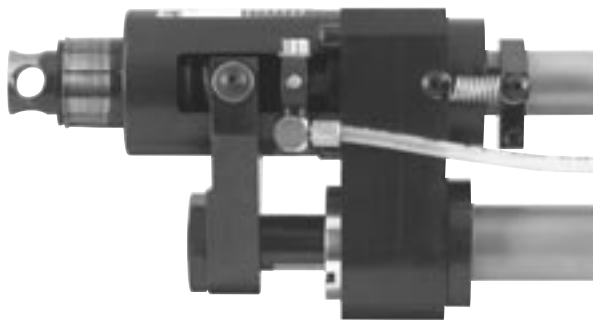

136SC Q-MATIC SELF-COLLECTING DRILL WITH DEPTH SENSING JIG COLLET FOOT

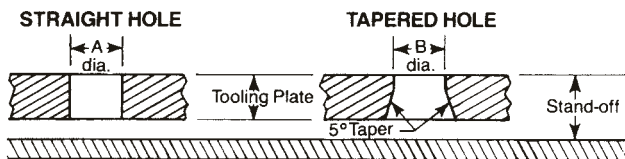

## INFORMATION REQUIRED TO ORDER JIG COLLET FOOT TOOLS:

- (1) Specify tooling plate hole size—diameter A or B—in order to determine collet size (see standard collet size chart).
- (2) When ordering depth sensing models, specify stand-off distance. (Top of tooling plate to work surface)
- (3) When ordering for straight hole tooling plates, specify tooling plate thickness.

## STANDARD COLLET SIZES

	Straight Hole A dia.	Tapered Hole B dia.
Depth Sensing	1.000 .875	.796 .670
Non-Depth Sensing	1.000 .875 .750 .625	.796 .670 .640 .500

Special collets available upon request.

## QUACKENBUSH™

### 136SC-150 Q-Matic Self-Colleting Drill Motor

#### Booster Pump Assembly

For increased clamping and feed force, an optional Booster Pump (Part No. 621482) is available. The pump provides extra clamp and feed when required.

The Booster Pump assembly will increase both clamp and feed forces by a factor of 2.5.

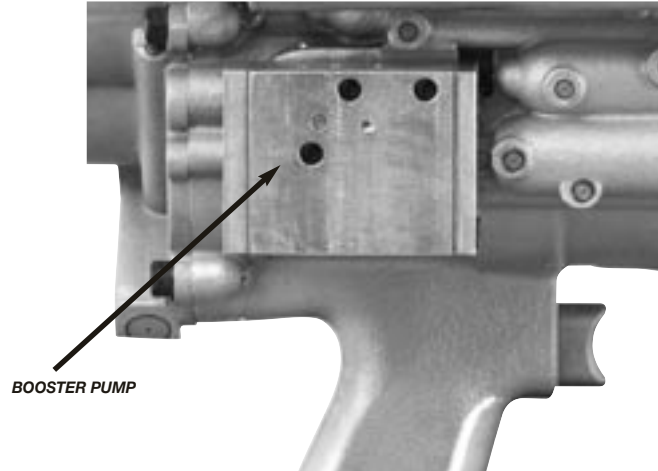

#### Mist Lubricator Assembly

A mist lubricator assembly is available to introduce coolant and air to the cutter. The lubricator is actuated by air from the accessory air tap on the motor side and only functions when the motor is running. The standard mist lubricator (Part No. 631297) can be filled with a hand pump. The optional mist lubricators (Part No. 631879 and 631880) are filled by a pressure pump.

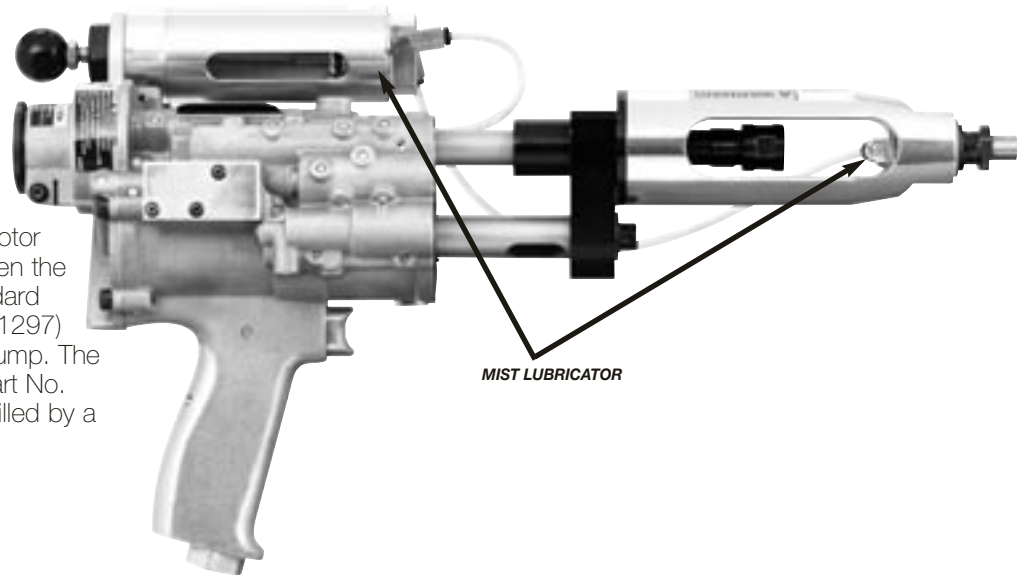

	Small	Large
Manual Fill	631878	
Pressure Fill	631879	631880

## Template Boss

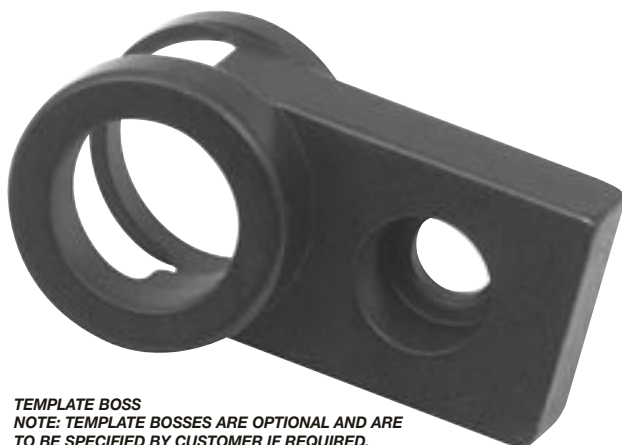

**TEMPLATE BOSS**  
NOTE: TEMPLATE BOSSES ARE OPTIONAL AND ARE TO BE SPECIFIED BY CUSTOMER IF REQUIRED.

Application		Template Boss Part No.
B Template Hole Dia.	C Sink Dia.	Code No.
.434	.271	623573
.434	.286	623574
.434	.317	623575
.497	.271	623576
.497	.286	623577
.497	.317	623578
.497	.349	623579
.497	.380	623580
.622	.317	623581
.622	.349	623582
.622	.380	623583
.622	.411	623584
.622	.489	623585
.622	.505	623586

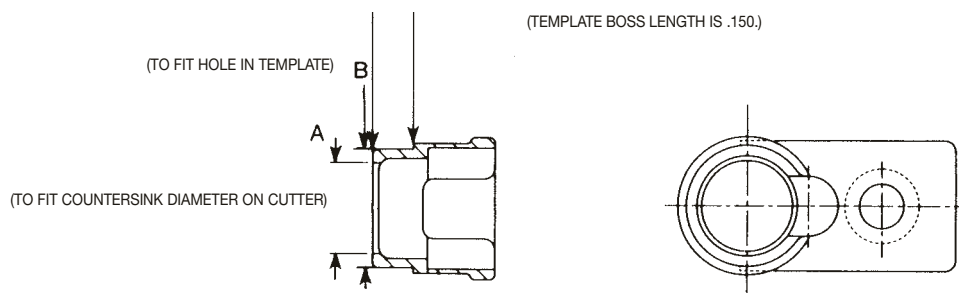

## Collets and Mandrels

Collets and Mandrels are supplied as standard equipment with each tool and must be specified when ordered.

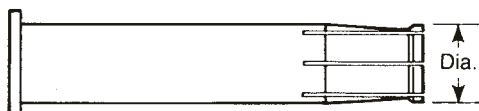

Typical Configuration of Collets for hole sizes up to .250 in.



Typical Configuration of Mandrels for hole sizes up to .250 in.

### INFORMATION NECESSARY TO ORDER COLLETS AND MANDRELS HOLE SIZE AND COLLET LENGTH CODE

**EXAMPLE:** Application is to drill a .250 dia. hole in .500 thick material using a template with a thickness of .125 in. SELECT Template Boss (See Template Boss Length information above). This application requires a .150 length. Using Material Thickness Grip Range chart based on .500 material thickness, the collet and mandrel Length Code is EITHER -40 or -63

Material Thickness Grip Range	
Temp. Boss Length .150	Collet Length Code*

#### Series 1000 Standard Collets

.00 - .37	- 23
.18 - .62	- 40
.43 - .87	- 63
.68 - 1.12	- 90

**ORDER:**      250-40      or      .250-63 collet/mandrel  
                   Hole Size ↑      Collet Length Code

## QUACKENBUSH™

### 15SC-D-112 Q-Matic Self-Colleting Drill

Drill Capacity: .4375" (11mm)  
 Countersink Capacity: 5/8" (15.9mm)  
 Feed Stroke: 1.125" (28.6mm)  
 Clamp Stroke: .5" (12.7mm)

- Semi-automatic self-colleting tool has automatic clamp/drill/retract cycle.
- Air motor, clamping and retract mechanism are air-operated; feed rate controlled by metering hydraulic fluid through an adjustable orifice.
- Tool has feed stroke of 1.125"; collet stroke of .5".

- Spindle can be adjusted to .375 inch to allow for variations in cutter lengths.
- Spindle feed rate is adjustable from .05 in./sec. through .40 in./sec.
- Drill point coolant port is provided in pressure foot.
- Trigger lock feature permits tool to cycle without constant operator attention.
- Spindle continues to rotate in forward direction while tool retracts.
- Tool stays clamped to workpiece until operator releases trigger lock.

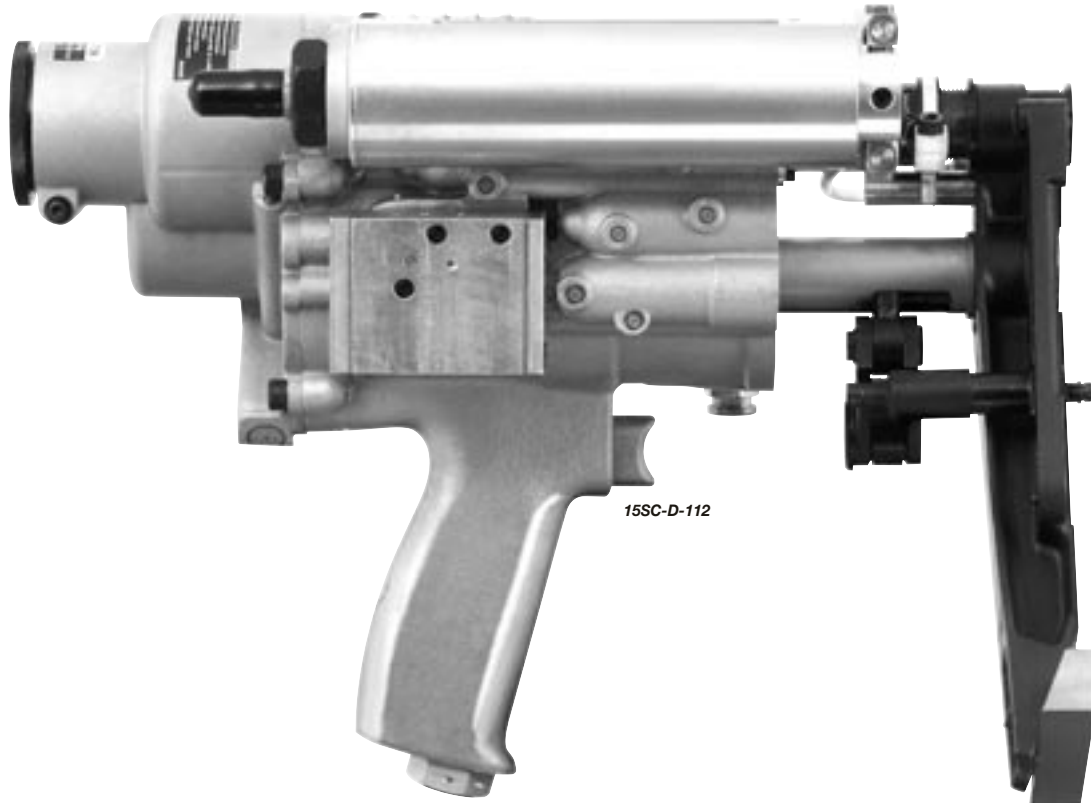

Model	Stroke		Feed Rate	Weight w/steel foot		Spindle Speeds (RPM)	Variable Distance Collet to Drill	Inlet	Minimum Hose Size
	Feed	Collet		lbs	kg				
15SC-D-112 (10SC)	1.125 in (28mm)	.5 in (12.5mm)	.05 to 4 in/sec	10.3	4.67	230, 400, 600, 1000, 1900, 3000, 4700, 6000, 12,000, 20,000	Min: .875 in (22mm) Max: 3.50 in (89mm)	.375" NPT	.5" (12.7mm)

Rated tool performance at 90 PSIG measured at toll inlet with motor running.

#### INFORMATION REQUIRED FOR ORDERING SELF-COLLECTING DRILL:

1. TOOL RPM
2. TYPE SPINDLE REQUIRED (Exact information concerning the cutter to be utilized in the drilling application must be provided in order to determine the proper spindle configuration. A drawing of the cutter should be provided for each application.)

#### 3. FOOT TYPE REQUIRED:

- Template Foot Right Hand OR Left Hand
- Jig Collet Foot Depth Sensing OR Non-Depth Sensing
- Drill Lock Bushing Foot 21000 series OR 22000 Series Bushing

#### 4. TOOLING INFORMATION

- Template Foot Models
  - Template Boss (see page 4-41)
  - Collet/Mandrel Assembly (see page 4-41)
  - Jig Collet Foot Models
- For depth sensing models, the stand-off distance (see page 4-39) must be provided. Collet/Mandrel Assembly (see page 4-41)

# Quackenbush® Self Colleting Machines

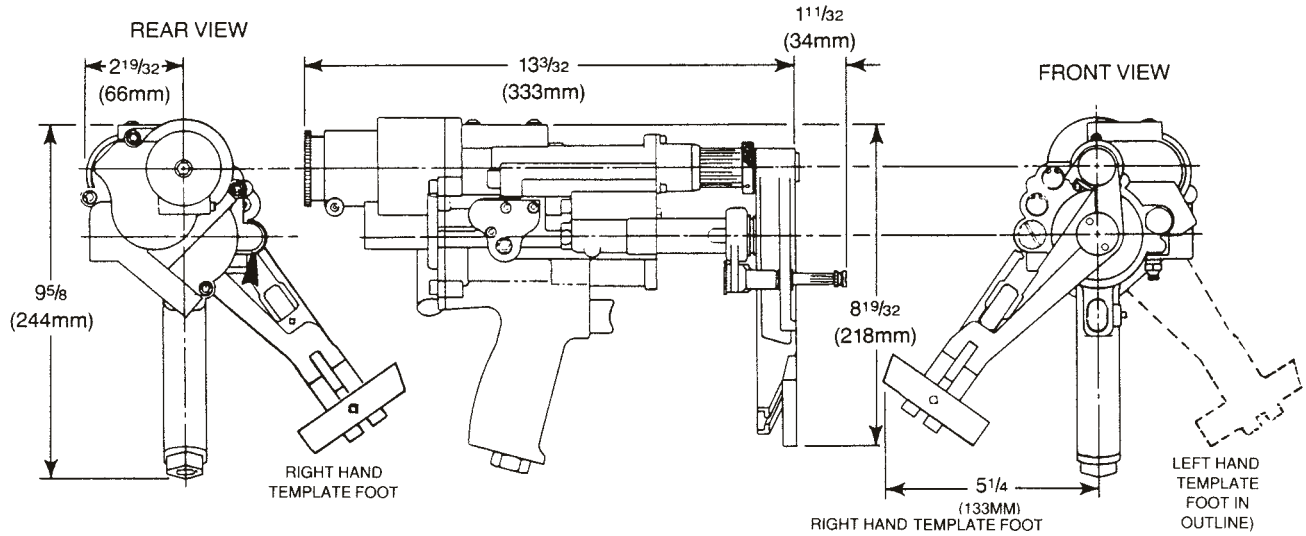

## Drill Lock Bushing Foot

The versatile Q-Matic 15SC Drill is available with a foot which accepts standard 21000 and 22000 series lock-type drill bushings. This foot design increases the versatility of the Q-Matic Drill so that it may be locked onto the rigid tooling plate using various drill bushing tips and their accessories.

## Drill Jig Collet Foot

The 15SC Q-Matic Drill is available with a jig collet foot, either with or without a depth sensing sleeve, for use with rigid tooling plates which have STRAIGHT or BACK TAPERED locating holes. This attachment, with a built-in sensing sleeve, will sense variations up to .125" in the distance between the work surface and the top of the tooling plate, which allows production drilling of holes with countersink to precise limits. A port has been provided in the foot to deliver coolant to the drill point.



15SC Q-MATIC SELF-COLLECTING DRILL WITH NON-DEPTH SENSING JIG COLLET FOOT AND THROUGH SPINDLE COOLANT

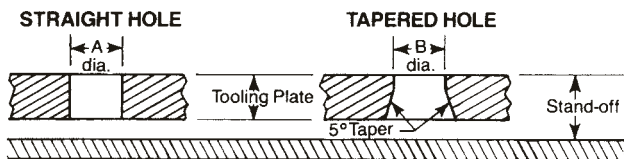

## INFORMATION REQUIRED TO ORDER JIG COLLET FOOT TOOLS:

- (1) Specify tooling plate hole size—diameter A or B—in order to determine collet size (see standard collet size chart).
- (2) When ordering depth sensing models, specify stand-off distance. (Top of tooling plate to work surface)
- (3) When ordering for straight hole tooling plates, specify tooling plate thickness.

## STANDARD COLLET SIZES

	Straight Hole A dia.	Tapered Hole B dia.
Depth Sensing	1.000 .875	.796 .670
Non-Depth Sensing	1.000 .875 .750 .625	.796 .670 .640 .500

Special collets available upon request.

## QUACKENBUSH™

### 15SC-D-112 Q-Matic Self-Collecting Drill Motor

#### Booster Pump Assembly

For increased clamping and feed force, an optional Booster Pump (Part No. 621482) is available. The pump provides extra clamp and feed force when drilling Titanium or taper drilling applications.

The Booster Pump assembly will increase both clamp and feed forces by a factor of 2.5. The pump is easily installed on the Q-Matic Drill by replacing the cover supplied with the tool with the Booster Pump using the three screws supplied with the pump.

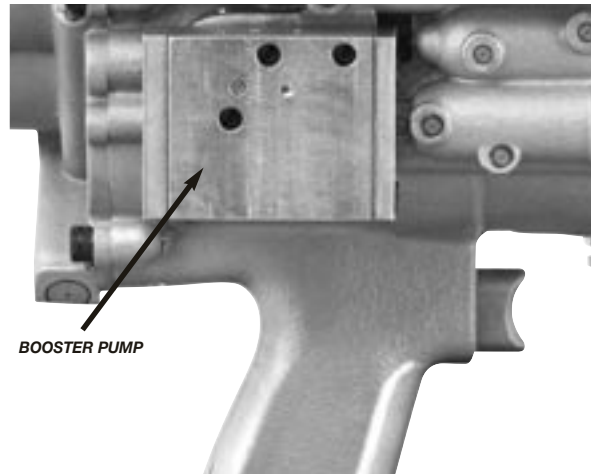

BOOSTER PUMP

#### Mist Lubricator Assembly

A mist lubricator assembly is available to introduce coolant and air to the cutter. The lubricator is actuated by air from the accessory air tap on the motor side and only functions when the motor is running. The standard mist lubricators (Part No. 631881 and 631883) are filled with a hand pump. The optional mist lubricators (Part No. 631882 and 631884) are filled by a pressure pump.

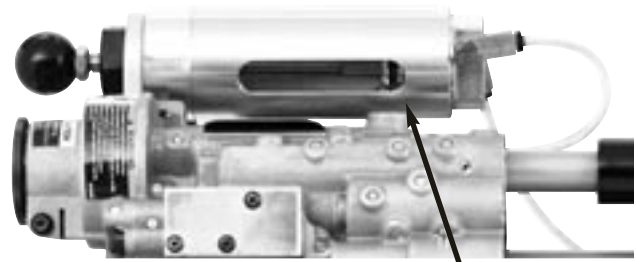

MIST LUBRICATOR

	Small	Large
Manual Fill	631881	631883
Pressure Fill	631882	631884

#### Jig Collet Foot Attachments

##### Depth Sensing Jig Collet Foot

Depth sensing jig collet foot is used for accurately drilling and countersinking hole layouts utilizing a simple fixture plate. The cutter passes centrally through the drillmotor collet to produce holes concentric with the fixture plate holes. The depth sensing sleeve will drill and accurately countersink with fixture-to-workpiece variations of up to .125". Coolant and air blast port is fitted to the foot.

User must specify template hole and drill-countersink size as well as drill-countersink configuration.

##### Non Depth Sensing Jig Collet Foot

Non-depth sensing jig collet foot is similar to the above foot without depth sensing capability. This foot is used for straight drilling applications where "rough" depth sensing only is required. This foot grips straight shank drills utilizing an "O-W" type collet.

User must specify template hole and drill size.



15SC Q-MATIC SELF-COLLECTING DRILL WITH NON-DEPTH SENSING JIG COLLET FOOT AND THROUGH SPINDLE COOLANT

## Template Boss



**NOTE: WHEN ORDERING TOOLS, TEMPLATE BOSSES MUST BE SPECIFIED.**

Application		Template Boss Part No.	
B Template Hole Dia.	C Sink Dia.	With .150 Boss Length	With .200 Boss Length
.437	.271	622723-5	622740
.437	.286	622724-3	622741
.437	.317	622725-0	622742
.500	.271	622726-8	622743
.500	.286	622727-6	622744
.500	.317	622728-4	622745
.500	.349	622729-2	622746
.500	.380	622730-0	622747
.625	.317	622731-8	622748
.625	.349	622732-6	622749
.625	.380	622733-4	622750
.625	.411	622734-2	622751
.625	.489	622735-9	622752
.625	.505	622736-7	622753
.750	.505	622737-5	622754
.750	.625	622738-3	622755
.8750	.625	622739-1	622756

TEMPLATE BOSS LENGTH:  
 • USE .150 LENGTH FOR TEMPLATE THICKNESS TO .125  
 • USE .200 LENGTH FOR TEMPLATE

**NOTE:**  
 TEMPLATE BOSS LENGTH MUST EXCEED TEMPLATE THICKNESS. THICKNESS TO .187

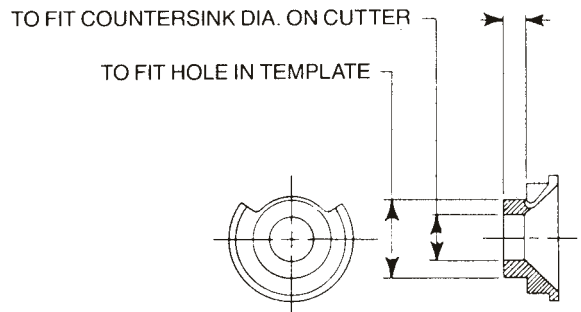

## Collets and Mandrels

Collets and Mandrels are supplied as standard equipment with each tool and must be specified when ordered.

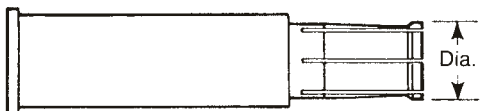

Typical Configuration of Collets for hole sizes up to .375 in.



Typical Configuration of Mandrels for hole sizes up to .375 in.

### INFORMATION NECESSARY TO ORDER COLLETS AND MANDRELS HOLE SIZE AND COLLET LENGTH CODE

**EXAMPLE:** Application is to drill a .375 dia. hole in .500 thick material using a template with a thickness of .130 in. SELECT Template Boss (See Template Boss Length information above). This application requires a .200 length. Using Material Thickness Grip Range chart based on .500 material thickness, the collet and mandrel Length Code is EITHER -63 or -90.

Material Thickness Grip Range				Collet Length Code
Using .100 & .150 Boss Length		Using .200 Boss Length		
Min	Max	Min	Max	
.00	.59	.00	.54	63
.05	.84	.00	.79	90
.30	1.09	.25	1.04	115
.55	1.34	.50	1.29	140

**ORDER:**      375-63      or      .375-90 collet/mandrel

Hole Size ↑      Collet Length Code



# Quackenbush® Self Collecting Machines

## QUACKENBUSH™

### 15SC-E-225 Q-Matic Self-Collecting Drill

Drill Capacity: .5" (12.7mm)  
 Countersink Capacity: .7813" (19.8mm)

Feed Stroke: 2.25" (57.2mm)  
 Clamp Stroke: .975" (22.2mm)

- Semi-automatic self-colleting tool has automatic clamp/drill/retract cycle.
- Air motor, clamping and retract mechanism are air-operated; feed rate controlled by external hydraulic feed control cylinder.
- Tool has feed stroke of 2.25" (57.2mm); collet stroke

of .875" (22.2mm).

- Variable foot spacing is adjustable from 1.00 in. minimum through 3.50 in. maximum.
- Drill point coolant port is provided in pressure foot.
- Trigger lock feature permits tool to cycle without constant operator attention.
- Spindle continues to rotate in forward direction while tool retracts.
- Tool stays clamped to workpiece until operator releases trigger locks.

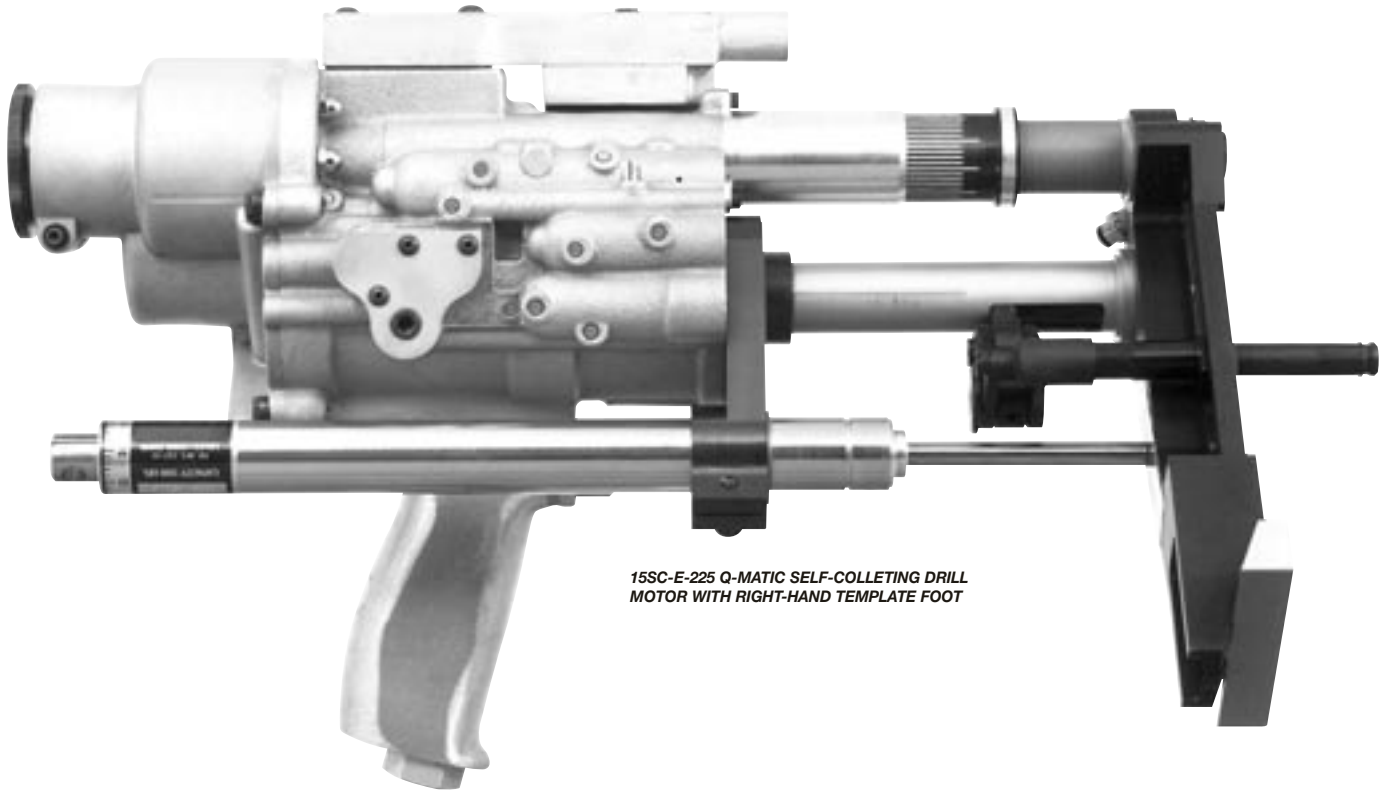

15SC-E-225 Q-MATIC SELF-COLLECTING DRILL  
 MOTOR WITH RIGHT-HAND TEMPLATE FOOT

Model	Stroke		Feed Rate	Weight w/steel foot		Spindle Speeds (RPM)	Variable Distance Collet to Drill	Inlet	Minimum Hose Size
	Feed	Collet		lbs	kg				
15SC-E-225	2.25 in (57mm)	.875 in (22.2mm)	Min. 1 min. per in. Max. 5 sec. per in.	12.5	5.67	230, 400, 600, 800, 1000, 1900, 3000, 4700, 6000, 1200, 20,000	Min: 1 in (25.4mm) Max. 3.5 in (89mm)	.375" NPT	.5" (12.7mm)

Rated tool performance at 90 PSIG measured at toll inlet with motor running.

**INFORMATION REQUIRED FOR ORDERING SELF-COLLECTING DRILL:**

1. TOOL RPM
2. TYPE SPINDLE REQUIRED (Exact information concerning the cutter to be utilized in the drilling application must be provided in order to determine the proper spindle configuration. A drawing of the cutter should be provided for each application.)

**3. FOOT TYPE REQUIRED:**

- Template Foot Right Hand OR Left Hand
- Jig Collet Foot Depth Sensing OR Non-Depth Sensing
- Drill Lock Bushing Foot 21000 series OR 22000 Series Bushing

**4. TOOLING INFORMATION**

- Template Foot Models
  - Template Boss (see page 4-45)
  - Collet/Mandrel Assembly (see page 4-45)
  - Jig Collet Foot Models
- For depth sensing models, the stand-off distance (see page 4-43) must be provided. Collet/Mandrel Assembly (see page 4-45)

# Quackenbush® Self Collecting Machines

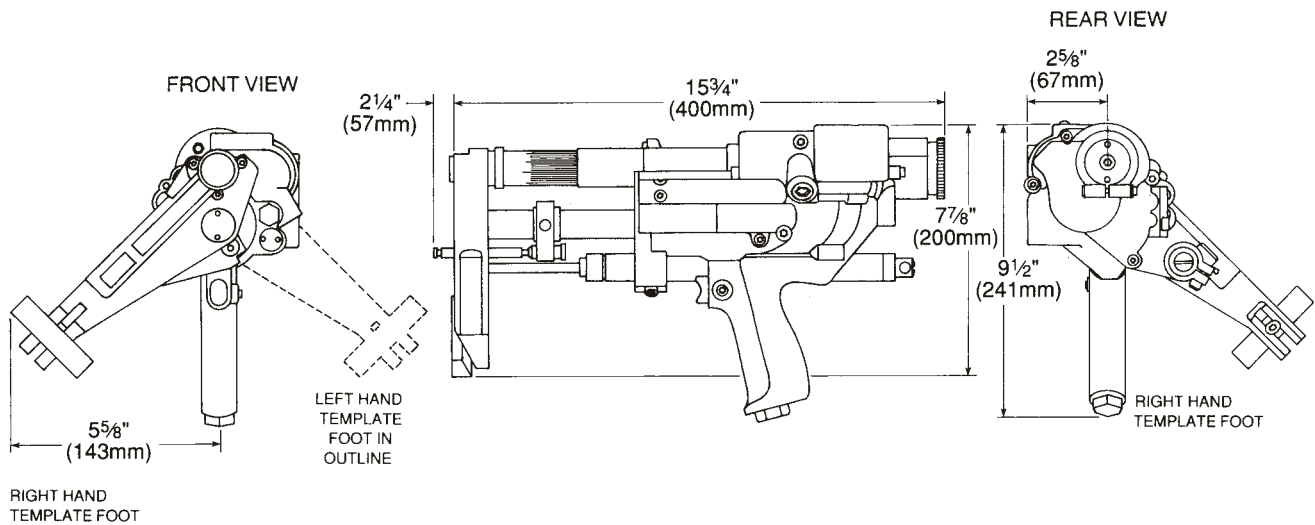

## Drill Jig Collet Foot Model

The 15SC-E-225 Q-Matic Drill is available with a jig collet foot, either with or without a depth sensing sleeve, for use with rigid tooling plates which have STRAIGHT locating holes or back TAPERED locating holes. This attachment with a built-in sensing sleeve, will sense variations up to .125" in the distance between the work surface and the top of the tooling plate, which allows production drilling of holes with a countersink to precise limits. A port has been provided in the foot to deliver coolant to the drill point.



15SC Q-MATIC SELF-COLLECTING DRILL WITH NON-DEPTH SENSING JIG COLLET FOOT AND THROUGH SPINDLE COOLANT

## Drill Lock Bushing Foot Model

The versatile Q-Matic 15SC-E-225 Drill is available with a foot which accepts standard 21000 and 22000 series lock-type drill bushings. This foot design increases the versatility of the Q-Matic Drill so that it may be locked onto the rigid tooling plate using various drill bushing tips and their accessories.

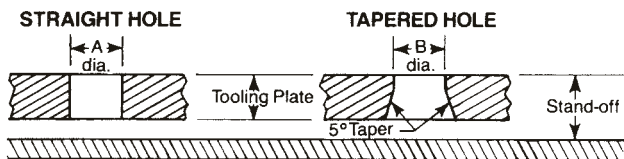

### STANDARD COLLET SIZES

	Straight Hole A dia.	Tapered Hole .B dia.
Depth Sensing	1.000 .875	.796 .670
Non-Depth Sensing	1.000 .875 .750 .625	.796 .670 .640 .500

### INFORMATION REQUIRED TO ORDER JIG COLLET FOOT TOOLS:

- (1) Specify tooling plate hole size—diameter A or B—in order to determine collet size (see standard collet size chart).
- (2) When ordering depth sensing models, specify stand-off distance. (Top of tooling plate to work surface)
- (3) When ordering for straight hole tooling plates, specify tooling plate thickness.

Special collets available upon request.

## QUACKENBUSH™

### 15SC-E-225 Q-Matic Self-Collecting Drill Motor

#### Booster Pump Assembly

For increased clamping and feed force, an optional Booster Pump (Part No. 621950) is available. The pump provides extra clamp and feed force when drilling Titanium or taper drilling applications.

The Booster Pump assembly will increase both clamp and feed forces by a factor of 2.5. The pump is easily installed on the Q-Matic Drill by replacing the cover supplied with the tool with the Booster Pump using the three screws supplied with the pump.

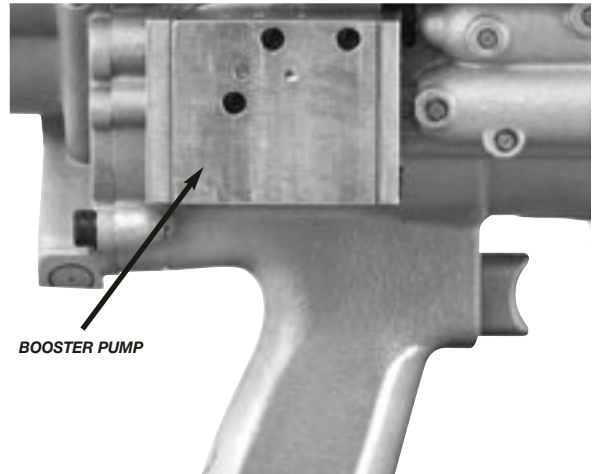

#### Mist Lubricator Assembly

A mist lubricator assembly is available to introduce coolant and air to the cutter. The lubricator is actuated by air from the accessory air tap on the motor side and only functions when the motor is running. The standard mist lubricators (Part No. 631881 and 631883) are filled with a hand pump. The optional mist lubricators (Part No. 631882 and 631884) are filled by a pressure pump.

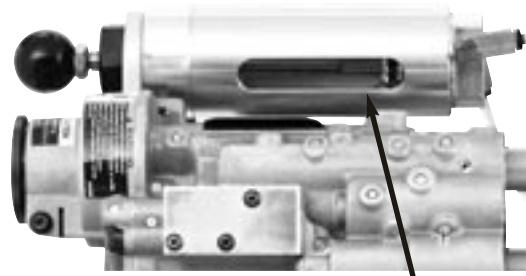

	Small	Large
Manual Fill	631881	631883
Pressure Fill	631882	631884

#### Jig Collet Foot Attachments

##### Depth Sensing Jig Collet Foot

Depth sensing jig collet foot is used for accurately drilling and countersinking hole layouts utilizing a simple fixture plate. The cutter passes centrally through the drillmotor collet to produce holes concentric with the fixture plate holes. The depth sensing sleeve will drill and accurately countersink with fixture-to-workpiece variations of up to .125". Coolant and air blast port is fitted to the foot.

User must specify template hole and drill-countersink size as well as drill-countersink configuration.

##### Non Depth Sensing Jig Collet Foot

Non depth sensing jig collet foot is similar to the above foot without depth sensing capability. This foot is used for straight drilling applications where "rough" depth sensing only is required. This foot grips straight shank drills utilizing an "O-W" type collet.

User must specify template hole and drill size.

## Template Boss



**TEMPLATE BOSS**  
NOTE: WHEN ORDERING TOOLS,  
TEMPLATE BOSSES MUST BE SPECIFIED.

Application		Template Boss Part No.	
B Template Hole Dia.	C Sink Dia.	With .150 Boss Length	With .200 Boss Length
.500	.375	624087	623896
.625	.500	623708	623897
.750	.625	623720	623898
.875	.750	623716	623899
1.000	.781	623725	
1.000	.875	624034	

TO ACCOMMODATE TEMPLATE THICKNESS:  
USE .150 LENGTH FOR TEMPLATE UP TO .125  
USE .200 LENGTH FOR TEMPLATE UP TO .187

**NOTE:**  
TEMPLATE BOSS LENGTH MUST EXCEED TEMPLATE THICKNESS.

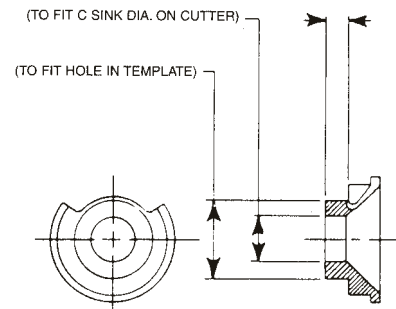

## Collets and Mandrels

Collets and Mandrels are supplied as standard equipment with each tool and must be specified when ordered.



Typical Configuration of Collets for hole sizes up to .375 in.



Typical Configuration of Mandrels for hole sizes up to .375 in.

### INFORMATION NECESSARY TO ORDER COLLETS AND MANDRELS HOLE SIZE AND COLLET LENGTH CODE

**EXAMPLE:** Application is to drill a .375 dia. hole in .500 thick material using a template with a thickness of .130 in. SELECT Template Boss (See Template Boss Length information above). This application requires a.200 length. Using Material Thickness Grip Range chart based on .500 material thickness, the collet and mandrel Length Code is EITHER -63 or -90.

**ORDER:**      375-63      or      .375-90 collet/mandrel

Hole Size ↑      Collet Length Code

Material Thickness Grip Range				Collet Length Code
Using .100 & .150 Boss Length		Using .200 Boss Length		
Min	Max	Min	Max	
.00	.59	.00	.54	63
.05	.84	.00	.79	90
.30	1.09	.25	1.04	115
.55	1.34	.50	1.29	140
.80	1.59	.75	1.54	163
1.05	1.84	1.00	1.79	190
1.30	2.09	1.25	2.04	215
1.55	2.34	1.50	2.29	240

## QUACKENBUSH™

### 180SC-225 Q-Matic Self-Colleting Drill Motor

Drill Capacity: .5625" (14.3mm)  
Countersink Capacity: .875" (22.2mm)

Feed Stroke: 2.25" (57.2mm)  
Clamp Stroke: .875" (22.2mm)

- Semi-automatic self-colleting tool has automatic clamp/drill/retract cycle.
- Air motor, clamping and retract mechanism are air-operated; feed rate controlled by external hydraulic feed control cylinder.
- Tool has feed stroke of 2.25" (57.2mm); collet stroke of .875"

- Variable foot spacing is adjustable from 1.00 in. minimum through 3.50 in. maximum.
- Drill point coolant port is provided in pressure foot.
- Trigger lock feature permits tool to cycle without constant operator attention.
- Spindle continues to rotate in forward direction while tool retracts.
- Tool stays clamped to workpiece until operator releases trigger locks.

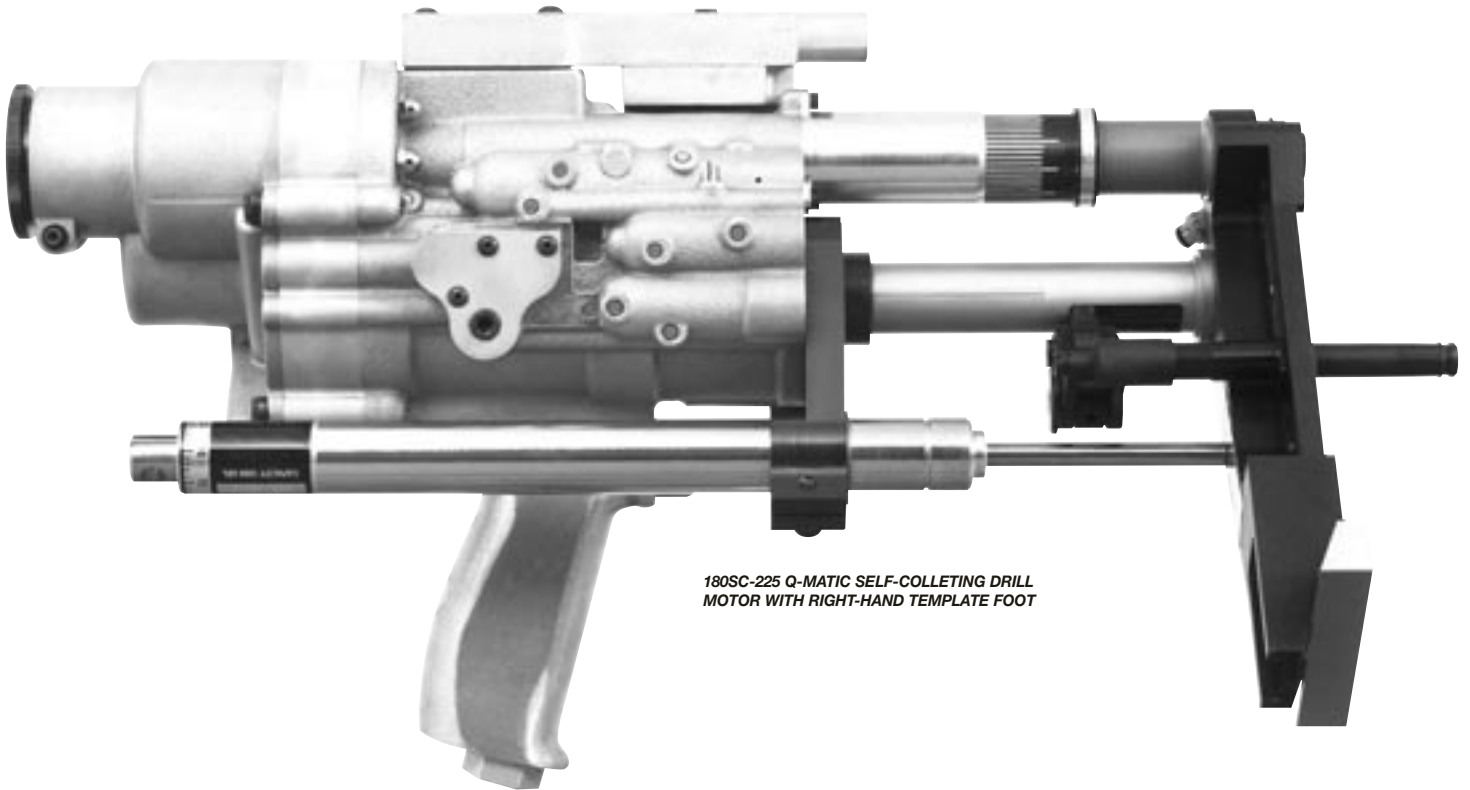

180SC-225 Q-MATIC SELF-COLLECTING DRILL MOTOR WITH RIGHT-HAND TEMPLATE FOOT

Model	Stroke		Feed Rate	Weight w/steel foot		Spindle Speeds (RPM)	Variable Distance Collet to Drill	Inlet	Minimum Hose Size
	Feed	Collet		lbs	kg				
180SC-225	2.25 in (57mm)	.5 in (12.5mm)	Min. 1 min. per in. Max. 5 sec. per in.	14.5	6.52	240, 420, 650, 850 1050, 2000, 3100 4900, 6300, 12500, 21,000	Min: 1 in (25.4mm) Max. 3.5 in (89mm)	.375" NPT	.5" (12.7mm)

Rated tool performance at 90 PSIG measured at toll inlet with motor running.

#### INFORMATION REQUIRED FOR ORDERING SELF-COLLECTING DRILL:

1. TOOL RPM
2. TYPE SPINDLE REQUIRED (Exact information concerning the cutter to be utilized in the drilling application must be provided in order to determine the proper spindle configuration. A drawing of the cutter should be provided for each application.)

#### 3. FOOT TYPE REQUIRED:

- Template Foot Right Hand OR Left Hand
- Jig Collet Foot Depth Sensing OR Non-Depth Sensing
- Drill Lock Bushing Foot 21000 series OR 22000 Series Bushing

#### 4. TOOLING INFORMATION

- Template Foot Models
  - Template Boss (see page 4-49)
  - Collet/Mandrel Assembly (see page 4-49)
  - Jig Collet Foot Models
- For depth sensing models, the stand-off distance (see page 4-47) must be provided. Collet/Mandrel Assembly (see page 4-49)

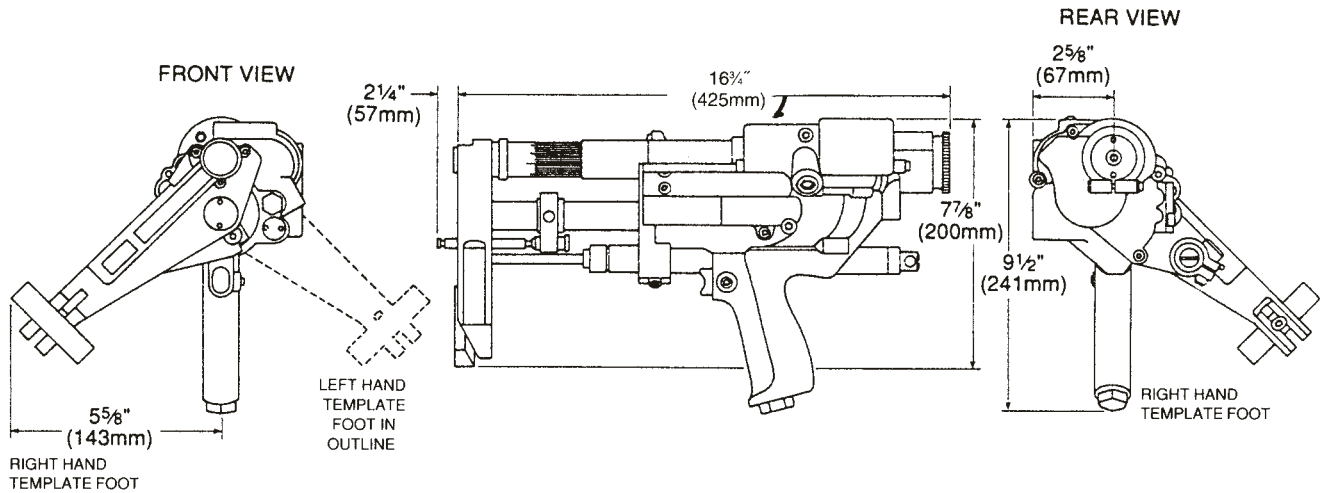

## Drill Jig Collet Foot Model

The 180SC-225 Q-Matic Drill is available with a jig collet foot, either with or without a depth sensing sleeve, for use with rigid tooling plates which have STRAIGHT locating holes or back TAPERED locating holes. This attachment with a built-in sensing sleeve, will sense variations up to .125" in the distance between the work surface and the top of the tooling plate, which allows production drilling of holes with a countersink to precise limits. A port has been provided in the foot to deliver coolant to the drill point.



## Drill Lock Bushing Foot Model

The versatile Q-Matic 180SC-225 Drill is available with a foot which accepts standard 21000 and 22000 series lock-type drill bushings. This foot design increases the versatility of the Q-Matic Drill so that it may be locked onto the rigid tooling plate using various drill bushing tips and their accessories.

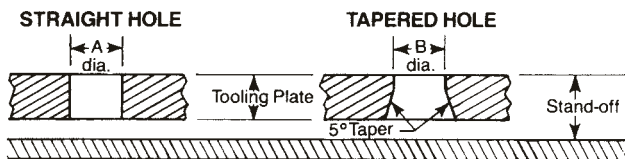

### STANDARD COLLET SIZES

	Straight Hole A dia.	Tapered Hole .B dia.
Depth Sensing	1.000 .875	.796 .670
Non-Depth Sensing	1.000 .875 .750 .625	.796 .670 .640 .500

### INFORMATION REQUIRED TO ORDER JIG COLLET FOOT TOOLS:

- (1) Specify tooling plate hole size—diameter A or B—in order to determine collet size (see standard collet size chart).
- (2) When ordering depth sensing models, specify stand-off distance. (Top of tooling plate to work surface)
- (3) When ordering for straight hole tooling plates, specify tooling plate thickness.

Special collets available upon request.

## QUACKENBUSH™

### 180SC-225 Q-Matic Self-Colleting Drill Motor

#### Booster Pump Assembly

For increased clamping and feed force, an optional Booster Pump (Part No. 621950) is available. The pump provides extra clamp and feed force when drilling Titanium or taper drilling applications.

The Booster Pump assembly will increase both clamp and feed forces by a factor of 2.5. The pump is easily installed on the Q-Matic Drill by replacing the cover supplied with the tool with the Booster Pump using the three screws supplied with the pump.

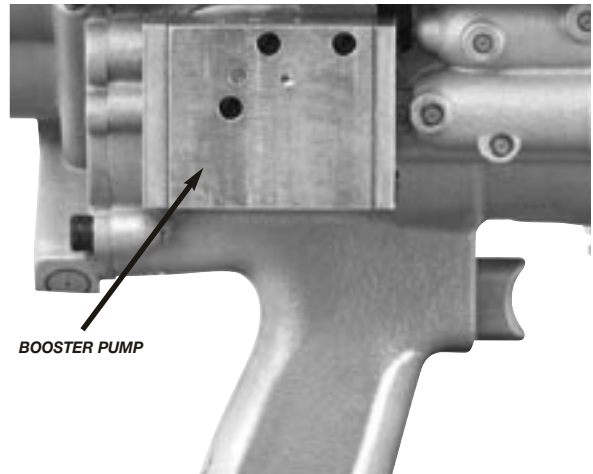

BOOSTER PUMP

#### Mist Lubricator Assembly

A mist lubricator assembly is available to introduce coolant and air to the cutter. The lubricator is actuated by air from the accessory air tap on the motor side and only functions when the motor is running. The standard mist lubricators (Part No. 631881 and 631883) are filled with a hand pump.

The optional mist lubricator (Part No. 631882 and 631884) are filled by a pressure pump.

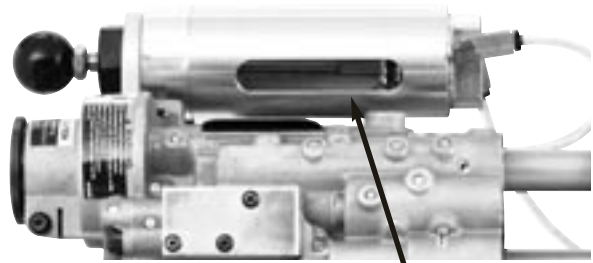

MIST LUBRICATOR

	Small	Large
Manual Fill	631881	631883
Pressure Fill	631882	631884

#### Jig Collet Foot Attachments

##### Depth Sensing Jig Collet Foot

Depth sensing jig collet foot is used for accurately drilling and countersinking hole layouts utilizing a simple fixture plate. The cutter passes centrally through the drillmotor collet to produce holes concentric with the fixture plate holes. The depth sensing sleeve will drill and accurately countersink with fixture-to-workpiece variations of up to .125". Coolant and air blast port is fitted to the foot.

User must specify template hole and drill-countersink size as well as drill-countersink configuration.

##### Non Depth Sensing Jig Collet Foot

Non depth sensing jig collet foot is similar to the above foot without depth sensing capability. This foot is used for straight drilling applications where "rough" depth sensing only is required. This foot grips straight shank drills utilizing an "O-W" type collet.

User must specify template hole and drill size.



180SC-225 Q-MATIC SELF-COLLECTING DRILL WITH JIG COLLET FOOT, THROUGH SPINDLE LUBRICATOR AND SPECIAL SWIVEL RING SUSPENSION ATTACHMENT.

## Template Boss



**TEMPLATE BOSS**  
NOTE: WHEN ORDERING TOOLS,  
TEMPLATE BOSSES MUST BE SPECIFIED.

Application		Template Boss Part No.	
B Template Hole Dia.	C Sink Dia.	With .150 Boss Length	With .200 Boss Length
.500	.375	624087	623896
.625	.500	623708	623897
.750	.625	623720	623898
.875	.750	623716	623899
1.000	.781	623725	
1.000	.875	624034	

TEMPLATE BOSS LENGTH:  
USE .150 LENGTH FOR TEMPLATE THICKNESS UP TO .125  
USE .200 LENGTH FOR TEMPLATE THICKNESS UP TO .187

**NOTE:**  
TEMPLATE BOSS LENGTH MUST EXCEED TEMPLATE  
THICKNESS.

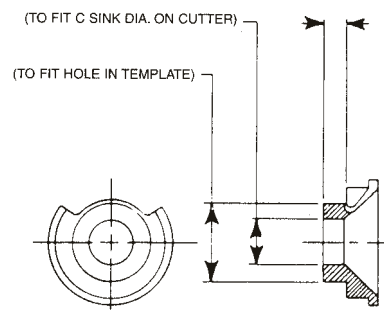

## Collets and Mandrels

Collets and Mandrels are supplied as standard equipment with each tool and must be specified when ordered.



Typical Configuration of Collets for hole sizes  
up to .375 in.



Typical Configuration of Mandrels for hole sizes  
up to .375 in.

### INFORMATION NECESSARY TO ORDER COLLETS AND MANDRELS HOLE SIZE AND COLLET LENGTH CODE

**EXAMPLE:** Application is to drill a .375 dia. hole in .500 thick material using a template with a thickness of .130 in. SELECT Template Boss (See Template Boss Length information above). This application requires a.200 length. Using Material Thickness Grip Range chart based on .500 material thickness, the collet and mandrel Length Code is EITHER -63 or -90.

**ORDER:**      375-63      or      .375-90 collet/mandrel

Hole Size ↑      Collet Length Code

Material Thickness Grip Range				Collet Length Code
Using .100 & .150 Boss Length		Using .200 Boss Length		
Min	Max	Min	Max	
.00	.59	.00	.54	63
.05	.84	.00	.79	90
.30	1.09	.25	1.04	115
.55	1.34	.50	1.29	140
.80	1.59	.75	1.54	163
1.05	1.84	1.00	1.79	190
1.30	2.09	1.25	2.04	215
1.55	2.34	1.50	2.29	240



## QUACKENBUSH™

### Mist Lubricator Assemblies

- Light-weight, self-contained unit features positive pressure, metered flow to drill point.
- Unit has lubricant capacity for 2000 holes without refilling.
- System is automatically activated when tool is in drill cycle, continues to supply lubricant to drill point until trigger is released.
- Position of drill has no affect upon unit supplying lubricant.
- Unit has adjustable flow control valve for metering lubricant flow.
- Mist lubricator is easily refilled from a 2 quart external lubricant pump fill reservoir (622900).
- Universal design fits all Quackenbush self-colleting tools.

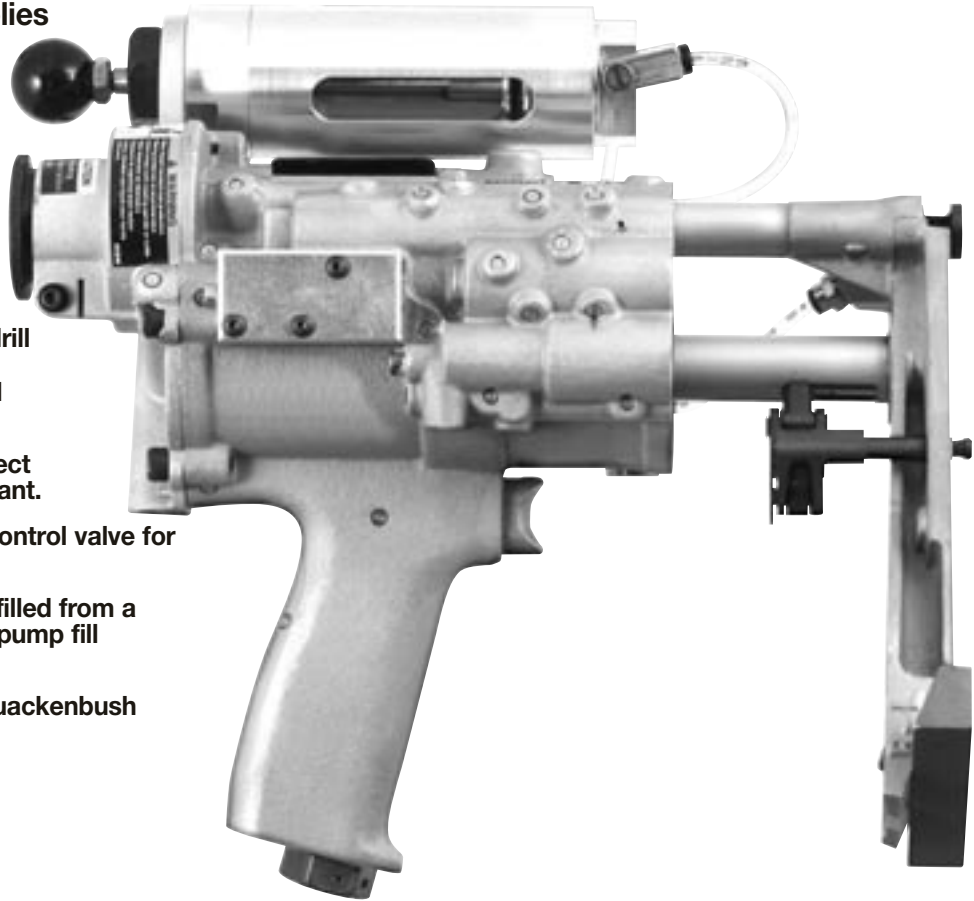

MANUAL FILL MIST LUBRICATOR  
ASSEMBLY SHOWN MOUNTED  
ON MODEL 136SC-B-118TF

### ORDERING INFORMATION

Mist Lubricator for Quackenbush Tools	Manual Fill	Pressure Fill
10 QNPD	621972	621973
136 SC	631297	631296
Standard Capacity All 15SC & 153SC	621970	621971
Large Capacity All 15SC & 153SC	631230	631235

## QUACKENBUSH™

### Q-MATIC Hydraulic Filler-Bleed Unit



- Completely self-contained unit makes filling and bleeding Q-Matic tools simple, quick, clean.
- Closed loop hydraulic system keeps fluid loss at a minimum.
- Clear tubing in return line makes air bubbles visible.
- Returned fluid is filtered before entering reservoir, ensuring fluid is free of contaminants.
- Hydraulic hose, pendant control are bundled together for easy, convenient use.
- Pump reservoir has 2 quart (1.91 L) capacity, can service up to 70 refills for 15QNPD; 30 refills for 136SC-112 and 25 refills for 15SC-112.

Model	Code No.	Fluid Pressure	Current	Amp. Draw @115V	Weight
Q-Matic Hydraulic Filler/Bleed Unit	621989	200psi	115V/AC 50/60 cycle	9.5 amps	29 lbs. (13.1 kg)

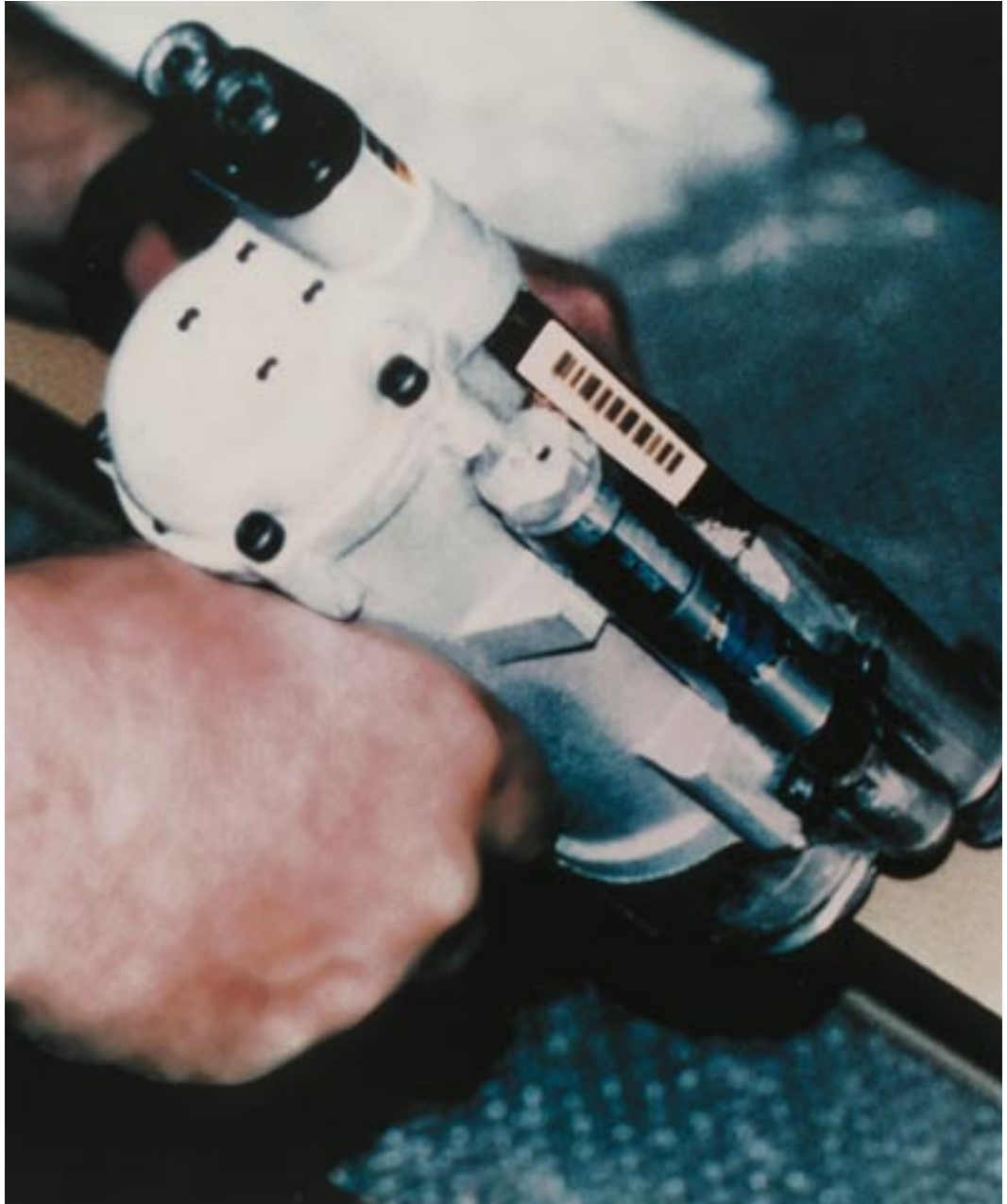

# Introduction

## Specialty Tools

Advanced Drilling Equipment from CooperTools is the most complete and comprehensive line of drilling systems available to the aerospace industry. This includes a line of specialty drills that are designed to help manufacturers accomplish specific tasks with tools that have been developed or modified to meet the unique requirements of the industry.

An example is the Nut Plate Drill designed to accommodate the nut plate fastener that is used in countless applications in aircraft manufacturing – out on the wings, in the fuselage, beneath the cockpit, in the lavatories and overhead bins – including where there is a need for repeated access to facilitate periodic inspections and maintenance.

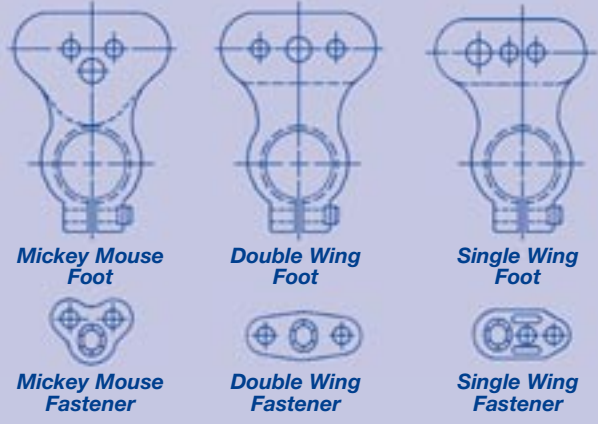

*Typically, any structure requiring the use of nut plate fasteners is designed with pre-spaced, pre-drilled holes. The location and size of these holes is determined by the type of nut plate fastener required. The collet/mandrel assembly of the nut plate drill is inserted into a pre-drilled hole which allows for the precision drilling of the two holes required for attaching Single Wing, Double Wing and Mickey Mouse.*

*Our nut plate drills can drill holes for all three types of nut plate fasteners by simply changing the spindle support block, lift finger and pressure foot.*

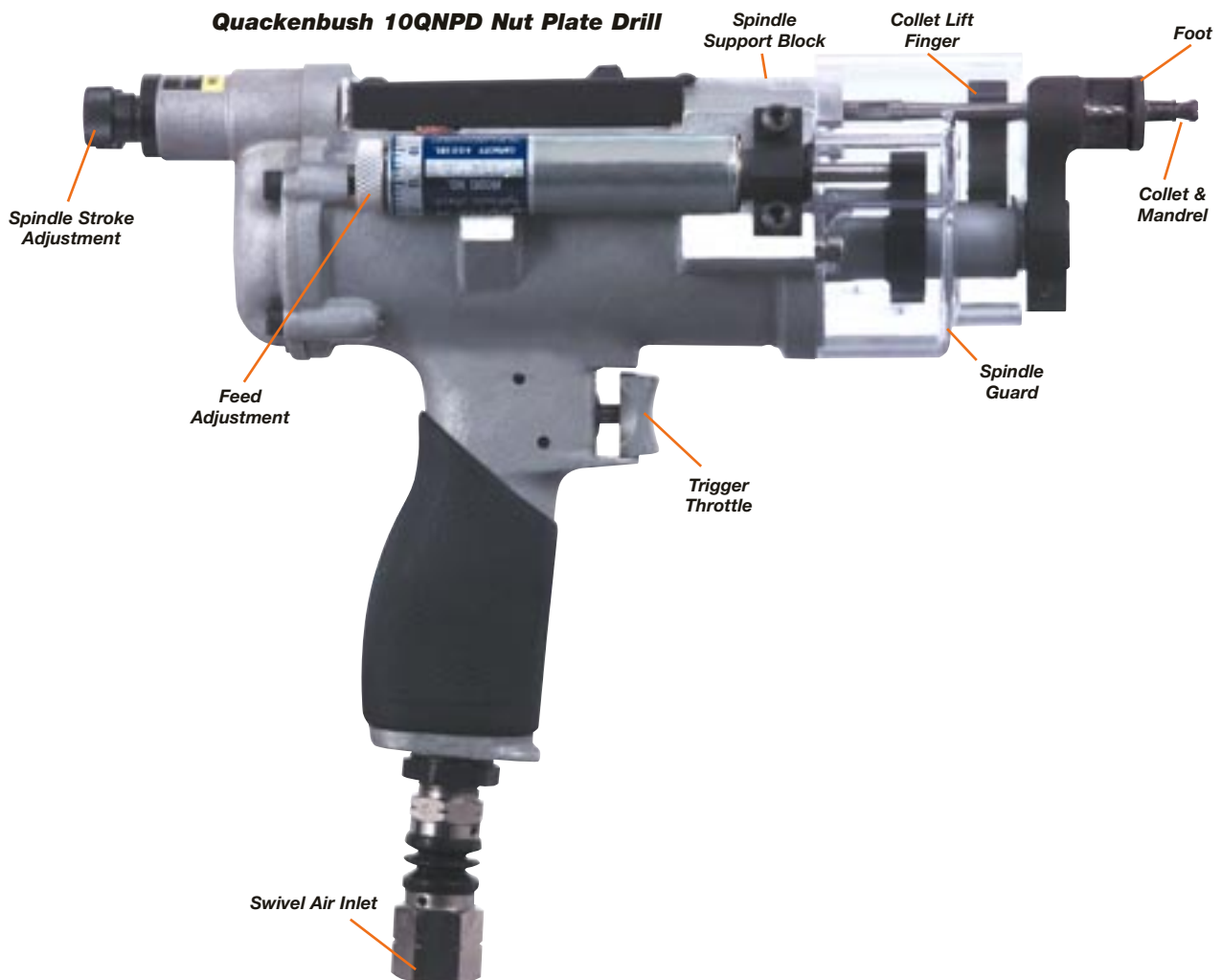

---

Our CD Drill, or composite drill, is designed to be used in the expanding range of non-metallic materials. It allows the operator to lock into a fixture or an inexpensive jig such as a template, providing a precise feed rate for enhanced performance and longer drill bit life.

The Doler PA and PB Drills are another example of our specialty drills. These drills typically marry a right angle drill to a clamping mechanism that allows workers to drill in extremely tight access situations where there is not room for a fixture but where there is also a concurrent demand for greater adherence to tolerances than is possible with a hand held drill.

Our Series PA tools are best suited for drilling small holes in very confined areas. They can reach into tight areas and drill precision holes with minimal operator effort. Our Series PD tools have a thrust booster for drilling larger holes.

**Doler CD4**



**Doler PB5**



## QUACKENBUSH™

### 10QNPD Nut Plate Drill Series

Capacity: Drill - .125" (3mm)  
Countersink: .25" (6mm)

Feed Stroke: .625" (15mm)  
Clamp Stroke: .4375" (11.1mm)

- New light weight ergonomic design.
- Adjustable external hydraulic feed rate control device. (no hydraulic bleeding required)
- Designed for low maintenance.
- Simultaneously drills and countersinks the two holes required for mounting nut plate fasteners.
- Individual, self-locking countersink depth adjustments on each spindle. (.001 increments)
- Expanding collet grips work with maximum holding force, providing positive attachment in order to produce more accurate holes and countersinks.
- Single tool can be used to drill and countersink holes for Single Wing, Double Wing, and Mickey Mouse fasteners by simply changing the spindle support block, lift finger, and pressure foot.
- Uses same support blocks, lift fingers and pressure feet used with the 15 QNPD tools.
- Available in 600 and 6000 rpm models with easy gear box conversions. (no increase in tool length)
- Variable spindle-to-spindle spacing provides wide range from minimum of .300 in. to 1.000 in. maximum in .001 increments.
- Fixed spindle spacings up to 1.125 in. are available.
- 10 QNPD "Mini" nutplates available in 6000 RPM model. Minimum spindle to spindle spacing for "mini" is .219"

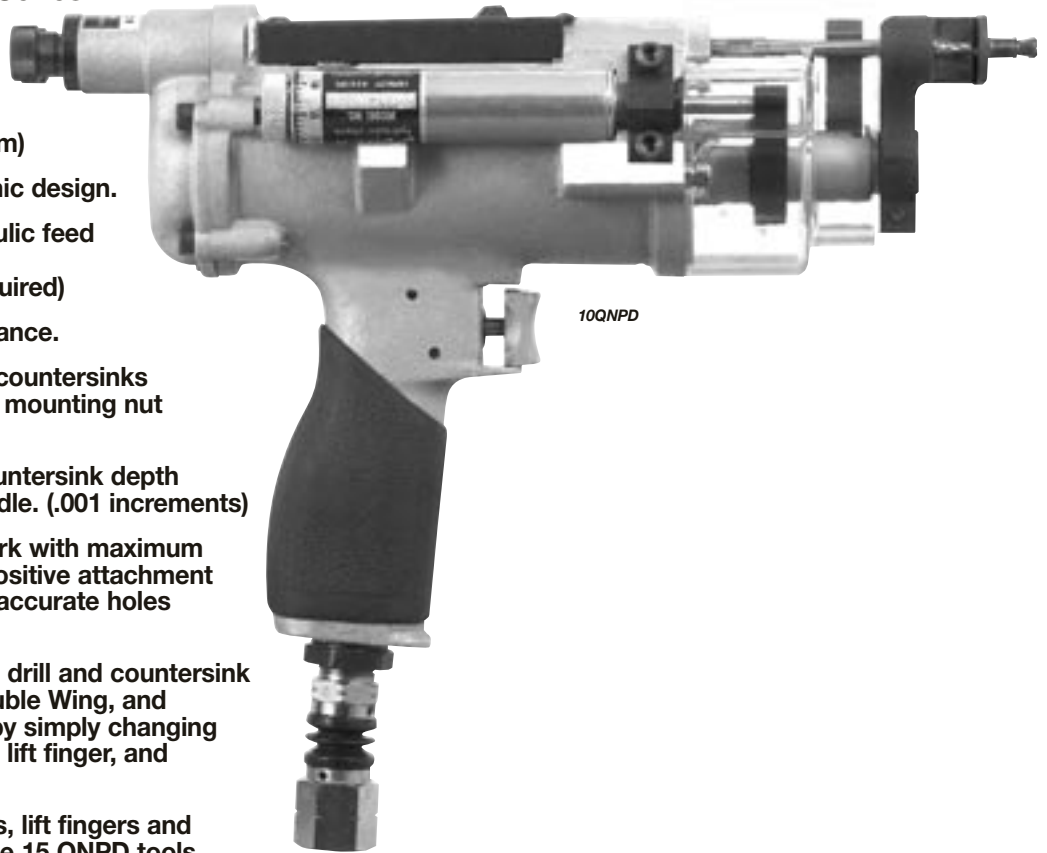

Model	Stroke	Weight	Spindle Speeds (RPM)	Inlet	Min. Hose Size
10QNPD	Feed Stroke .60 in. (15mm) Clamp Stroke: 7/16 in. (11mm)	5.0 lbs. (2.26kg)	600, 6000	.375 in. NPT	.375 in.

NOTE: Tool equipped with Foot, Collet and Mandrel Drills are not supplied with tool. Rated tool performance a 90 PSIG measured at tool inlet with motor running.

SEE PAGE 2 FOR SAFETY PRECAUTIONS.

**OPTIONAL EXTRA CHARGE ACCESSORIES**  
**BOOSTER PUMP ASSEMBLY: 621482**  
 Increases both clamp and feed forces by a factor of 2.5  
**MIST LUBRICATOR ASSEMBLY:** Introduces coolant and air to the cutter.

HAND FILL: 621972  
 PRESSURE FILL: 621973

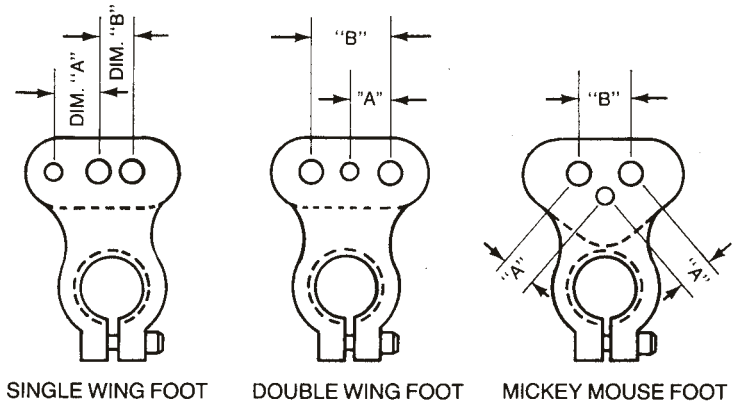
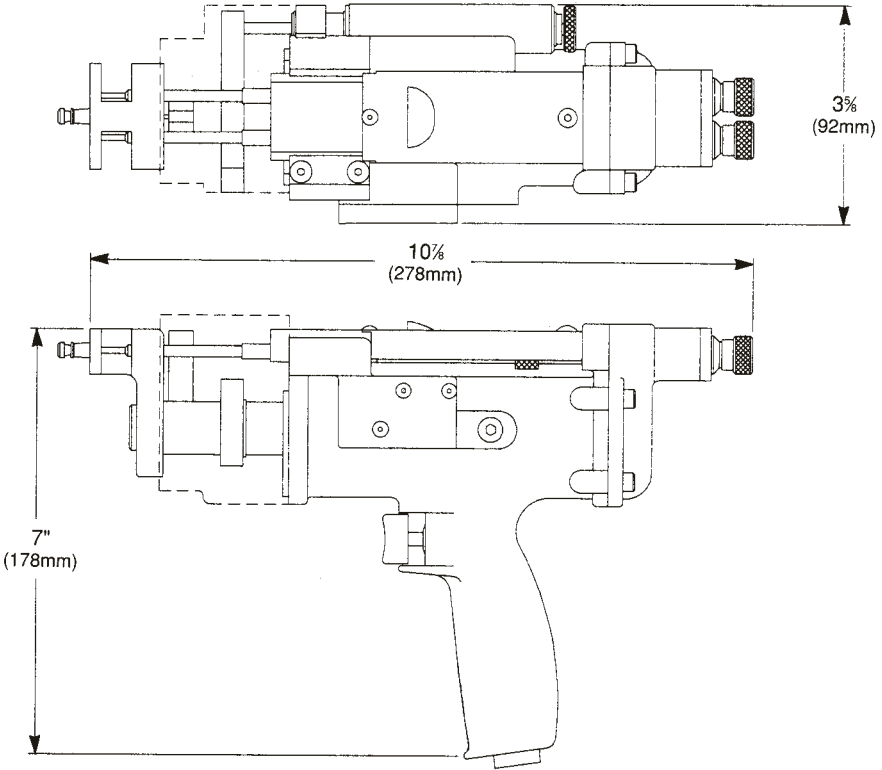

		SINGLE WING	DOUBLE WING	MICKY MOUSE
"A"	MIN	.344	-	.212
	MAX	.679	-	.500
"B"	MIN	.312	.343	.300
	MAX	1.000	1.125	1.000

**INFORMATION NECESSARY TO ORDER NUT PLATE DRILL**

1. Tool rpm \_\_\_\_\_
2. Type of foot \_\_\_\_\_
3. Collet to spindle spacing (A) \_\_\_\_\_
4. Spindle to spindle spacing (B) \_\_\_\_\_
5. Drill Shank Diameter (C) \_\_\_\_\_
6. Pilot Hole Diameter: \_\_\_\_\_  
Min. \_\_\_\_\_  
Max. \_\_\_\_\_
7. Thickness of material to be drilled \_\_\_\_\_

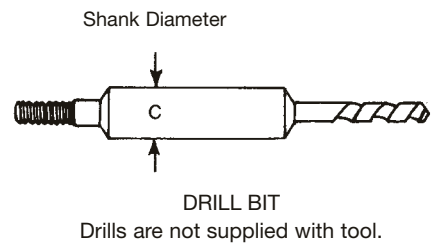

## DOLER®

### PA & PB Angle Drills

- PA - Thrust for drilling small holes in aluminum  
PB - Thrust for drilling large holes in aluminum and holes in titanium and steel
- Compact Power Feed
- Accessible into very confined areas
- Modular design
- Variety of angle heads, speeds, spindles, and yoke sizes.
- 0.9 hp motor
- Infinitely adjustable feed control
- Drill point lubricator to maximize hole quality

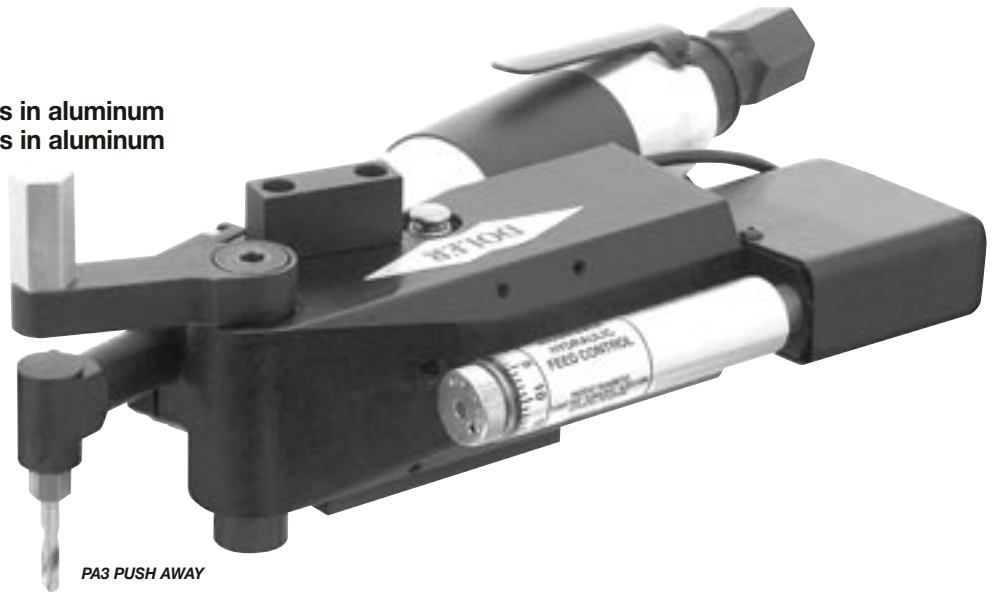

**PA 2 - 523 B - C 2 X X**

#### BASIS MODEL (XX)

PA = 70 lbs. Thrust  
PB = 160 lbs. Thrust

#### STYLE (X)

2 = Squeeze Yoke  
3 = Push Away  
5 = Taperlock or Short Yoke

#### ANGLE HEAD‡ - SPINDLE - SPEED (XXX)

(Select one three digit number)

No.	Spindle	Speed	No.	Spindle	Speed	No.	Spindle	Speed
-----	---------	-------	-----	---------	-------	-----	---------	-------

#### Buckeye Heavy Duty Angle (500 Series)

527	.25-28	300	534	.5625-40*	1,000	541	.3125-24	3,500
526	.25-28	500	533	.5625-40*	1,300	548	.3125-24	4,500
525	.25-28	750	532	.5625-40*	2,100	557	.375-24	300
524	.25-28	1,000	531	.5625-40*	3,500	556	.375-24	500
523	.25-28	1,300	538	.5625-40*	4,500	555	.375-24	750
522	.25-28	2,100	547	.3125-24	300	554	.375-24	1000
521	.25-28	3,500	546	.3125-24	500	553	.375-24	1300
528	.25-28	4,500	545	.3125-24	750	552	.375-24	2100
537	.5625-40*	300	544	.3125-24	1,000	551	.375-24	3500
536	.5625-40*	500	543	.3125-24	1,300	558	.375-24	4500
535	.5625-40*	750	542	.3125-24	2,100			

#### Buckeye Mini Angle (600 Series)

627	.25-28	450	637	.5625-40*	450	647	.3125-24	450
626	.25-28	750	636	.5625-40*	750	646	.3125-24	750
625	.25-28	1,100	635	.5625-40*	1,100	645	.3125-24	1,100
624	.25-28	1,400	634	.5625-40*	1,400	644	.3125-24	1,400
623	.25-28	1,850	633	.5625-40*	1,850	643	.3125-24	1,850
622	.25-28	3,000	632	.5625-40*	3,000	642	.3125-24	3,000
621	.25-28	5,000	631	.5625-40*	5,000	641	.3125-24	5,000
628	.25-28	6,000	638	.5625-40*	6,000	648	.3125-24	6,000

#### Erickson Collet Spindle (300 Series w/ 500 Series Angle Head)

827	**	300	824	**	1,000	821	**	3,500
826	**	500	823	**	1,300	828	**	4,500
825	**	750	822	**	2,100			

#### TAPERLOCK SERIES (X)

X = Not applicable  
1 = 21000 Series  
2 = 22000 Series  
3 = 23000 Series  
7 = Mini Taper-lok

#### ACCESSORY CODE (X)

X = None  
L = Drill Point Lubricator

#### YOKE DEPTH (X)

1 = 1.5 (#5 Style)  
2 = 4.5 (#2 Standard)  
3 = 5.3 (#2 Optional)  
4 = 7.2 (#Optional)  
0 = N/A (#3 Style)

#### YOKE WIDTH (X)

Model Code	500 Series	600 Series	800 Series
A	1.3	1.5	NA
B	2.1	2.3	NA
C	3.1	3.3	1.9
D	4.6	4.8	3.4
E	6.8	7.0	NA
O	N/A #3 Style		

#### THRUST ACTUATOR (X)

B = Button  
T = Toggle  
C = Combined with Motor Lever  
(Use with taper-lok only)

\* Use with Collet Page 5-10  
\*\* Erickson 300 Collet Chuck  
‡ See page 5-10 for Angle Head Dimensions.

#### SPECIFICATIONS:

Air Consumption: 35 scfm  
Air Inlet Size: .375 NPT  
Recommended Hose Size: .5" I.D.  
Power: 0.9 HP

Thrust: 70 lbs. (PA) 160 lbs. (PB)  
Stroke: 1.25"  
Feed Rate: Infinite Adjustment  
Spindle: See chart  
Weight: PA2 - 7.5 lbs.  
PA5 - 5.7 lbs.  
PB2 - 8.9 lbs.  
PB5 - 7.1 lbs.

#### OPTIONAL EQUIPMENT

(See Page 5-10)  
26-014-xxx Riser Block (xxx=block height)

#### EXTRA COST ACCESSORIES

(See Page 5-10)  
Quick Adjustable Yoke  
Mini Taper-lok Bushing  
Drill Point Lubricator



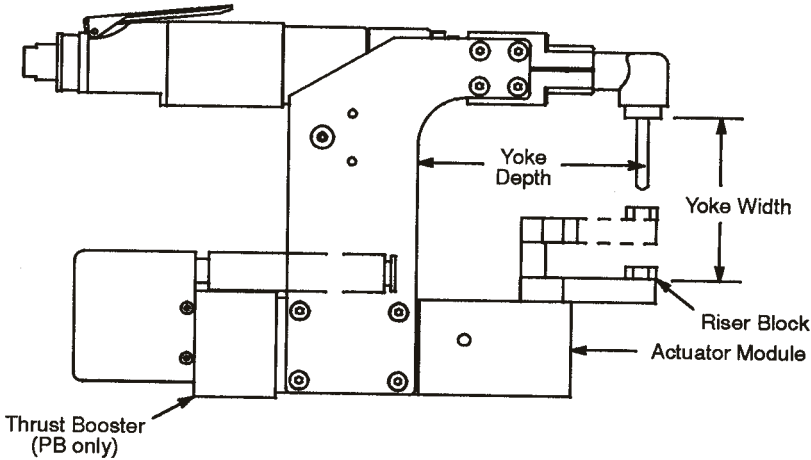

PA5 & PB5 Style

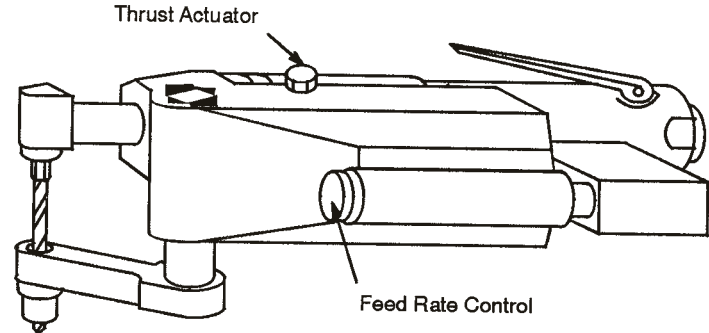

PA3 & PB3 Style

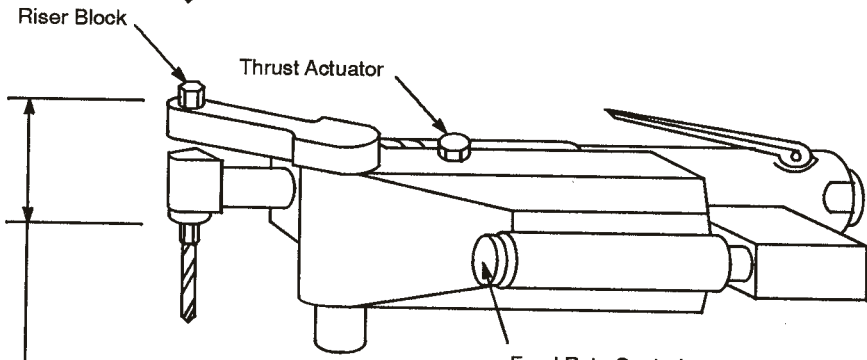

Buckeye 600 Mini Angle Head = 1.81"  
 Buckeye 500 Heavy Duty Angle Head = 1.96"  
 Erickson Collet Chuck Angle Head = 3.50"

**TOOL SELECTION:**

1. The PA is suitable for drilling aluminum to 1/4" diameter. Use the PB for larger holes in aluminum and for drilling titanium, inconel, steel, etc.
2. If space permits, the collet spindle is generally preferred because conventional straight shank drill bits can be used and cutter runout is minimal.
3. Use the compact angle if space constraints require it.
4. The toggle thrust actuator is normally used for slow speed drilling where cycle times are relatively long.
5. Drill point lubrication will normally improve hole quality and extend cutter life (see page 5-11). Use bendable steel tubing from PL500 luber to drillpoint.

# Specialty Drills

## DOLER®

### CD Portable Drills

- Compact portable Airfeed Drill
- Lightweight and comfortable grip
- Variety of speeds and strokes
- 0.9 or 1.3 HP motors
- Great for composite drilling and countersinking

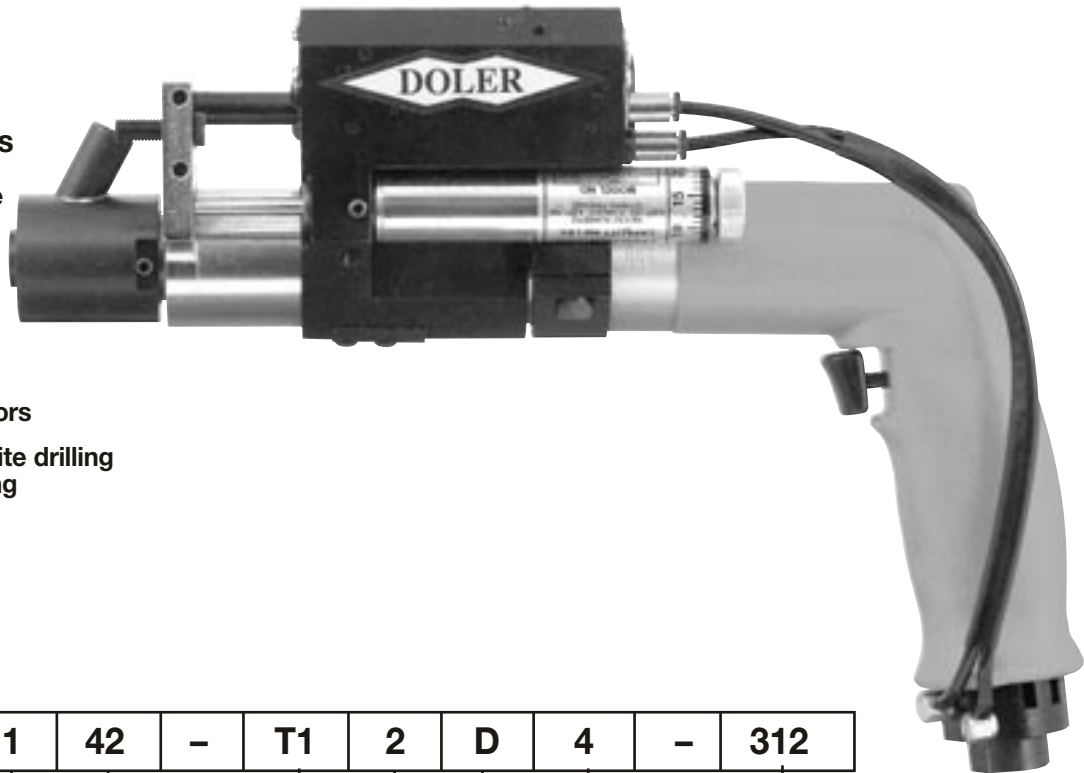

CD	1	42	-	T1	2	D	4	-	312
----	---	----	---	----	---	---	---	---	-----

#### STROKE

1 - 1" Stroke    2 - 2" Stroke

#### POWER/SPINDLE SPEED (XX)

4 - 0.9 HP	5 - 1.3 HP
1 - 500 RPM	3 - 1000 RPM
2 - 800 RPM	4 - 1700 RPM
3 - 1300 RPM	6 - 4500 RPM
4 - 1900 RPM	7 - 5400 RPM
5 - 3200 RPM	9 - 18000 RPM
6 - 5200 RPM	
7 - 6200 RPM	V - 0.7 HP Variable Speed
9 - 20000 RPM	1 - 150-550 RPM
	2 - 400-1200 RPM
	3 - 700-2400 RPM

#### NOSEPIECE (XX)

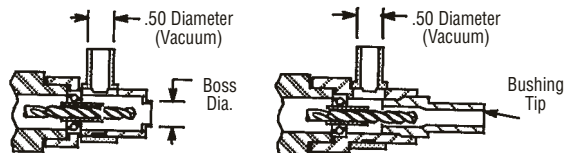

Code	Vacuum	Boss Dia.	Boss Proj.	Code	Vacuum	Cutter Guide	Taperlock Series
xx	No nosepiece			P1	Yes	No	21000
B1	Yes	0.500	0.05	P2	Yes	No	22000
B2	Yes	0.500	0.10	P3	Yes	No	23000
B3	Yes	0.625	0.05	P6	Yes	Yes	21000
B4	Yes	0.625	0.10	P7	Yes	Yes	22000
B5	Yes	0.750	0.05	P8	Yes	Yes	23000
B6	Yes	0.750	0.10	T1	No	No	21000
				T2	No	No	22000
				T3	No	No	23000
				T4	No	No	24000
				T6	No	Yes	21000
				T7	No	Yes	22000
				T8	No	Yes	23000
				M1	No	Yes	Mini

#### CUTTER DIAMETER (XXX)

Specify size in inches.  
Example: 312 = .312 inches  
(Use cutter body dia. of drill/c'sink  
(Use drillbit dia. for drill only)  
XXX = Not Applicable

#### SPINDLE (X)

1 = .25" Jacobs Chuck  
2 = 1/4"-28 x .375" "Spacematic"  
3 = 1/4"-28 x .500" "Spacematic"  
4 = Erickson 200 Chuck

#### COUNTERSINK OR DRILL ONLY (X)

C = Countersink (positive depth stop)  
D = Drill only

#### STROKE (X)

1 = 1" Stroke  
2 = 2" Stroke

#### SPECIFICATIONS:

Air Consumption: 30 scfm  
Air Inlet Size: .375 NPT  
Recommended Hose Size: .5" I.D.  
Power: 0.9 or 1.3 HP

Thrust: 90 lbs. (1" stroke) 120 lbs. (2" stroke)  
Stroke: 1" or 2"  
Depth Accuracy: Adjustable within .001  
Weight: 5.8 lbs. (1" stroke)  
7.0 lbs. (2" stroke)

#### EXTRA COST ACCESSORIES

Drill Point Lubricator (See Pages 5-10 & 5-11)  
Venturi Vacuum (See Page 5-11)  
Dead Handle (See Page 5-11)

Dimensional Data - CD Portable Drills

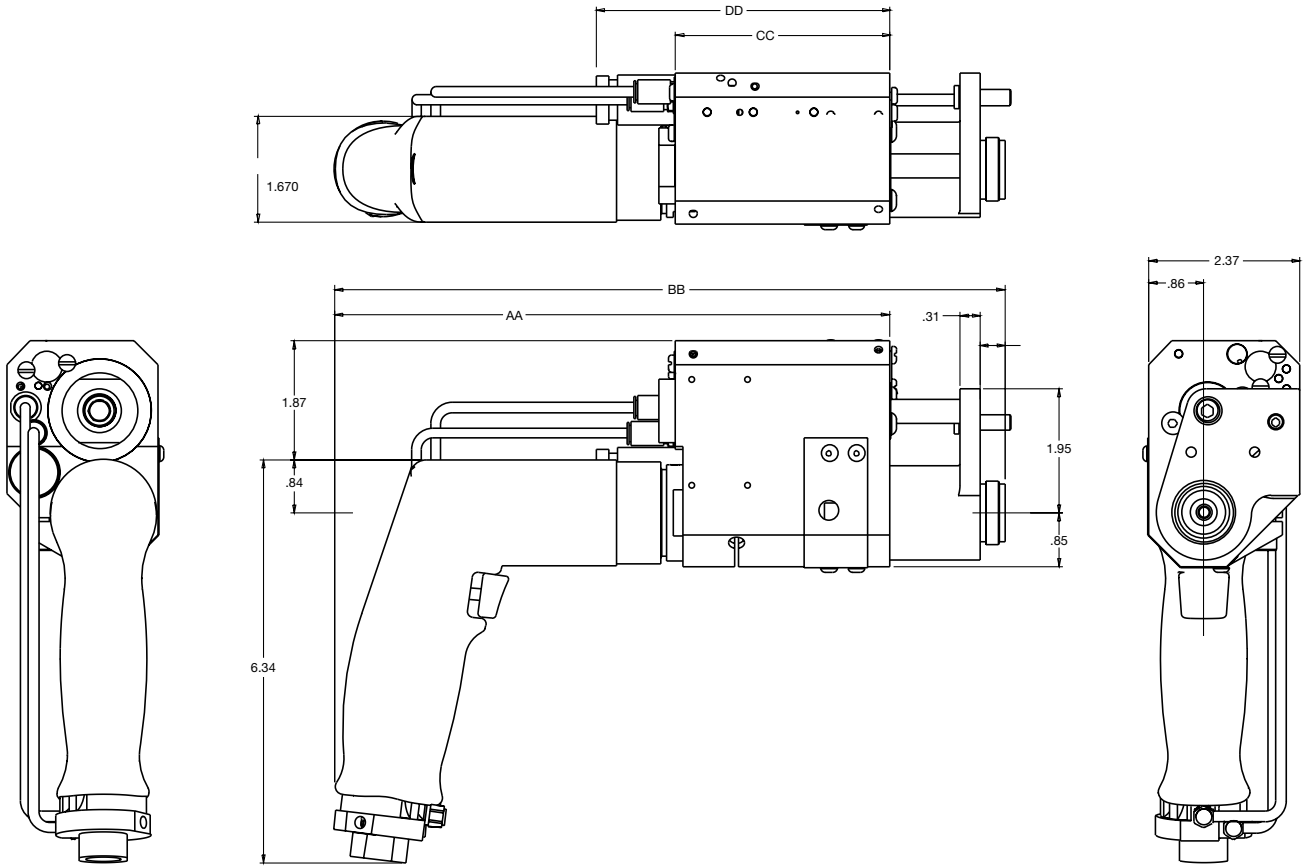

**Template Boss**

Cutter Guide Bushing is mounted in a sealed ball bearing which greatly reduces wear, extends bushing life and maintains hole accuracy.

The vacuum port connects to a central vacuum system, or shop vacuum, or the optional Doler Venturi Vacuum (pg. 5-11).

The Template Boss is used with a Strip Template to locate the drill point. The Boss must extend through the Template and contact the workpiece to maintain accurate countersink depths.

**Taper-Lok Nosepiece**

Mini Twistlock (pg. 5-11) or Taper-Lok with or without cutter guide, with or without a vacuum port.

When using a cutter guide, enlarge the I.D. of the Bushing Tip to avoid cutter contact. Normally used with PCD cutters.

See pages 1-3 for Taper-lok Fixturing.

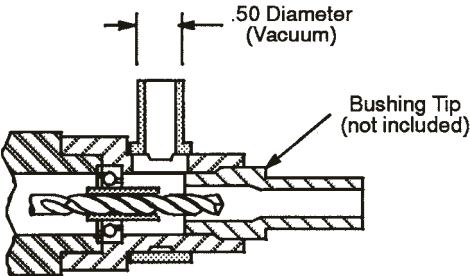
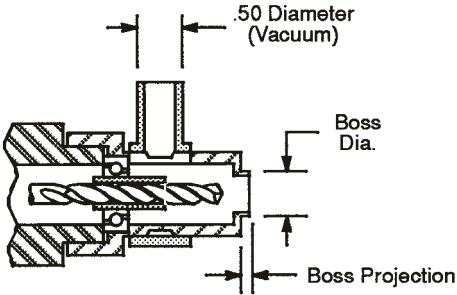

# Specialty Drills Accessories

## PA-5 with Mini-Twistlok Bushing Tips

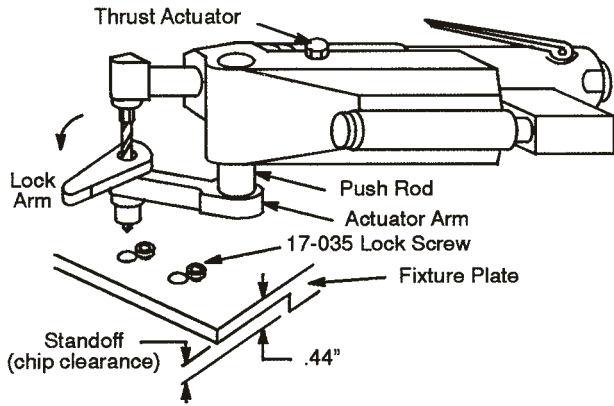

## Mini Twistlok Bushing Tip

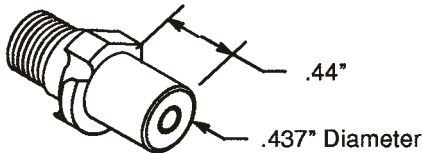

Part Number: 22-703-XXX

Insert the cutter guide diameter for "XXX". Example: 22-700-250 has a .250 guide diameter. Maximum cutter diameter is .313.

Miniature version of Taper-lok Bushing Tips.

## Fixture Hole Specification for Mini Twistlok

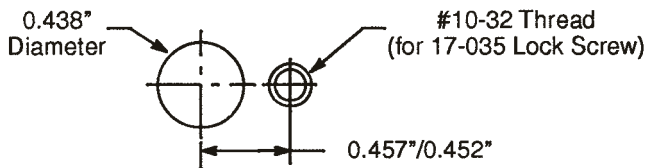

## 21000 & 22000 Series Bushing Tips for PA-5

Similar operation as with Mini-Twistlok Tips. Use industry standard 21000 or 22000 Bushing Tips.

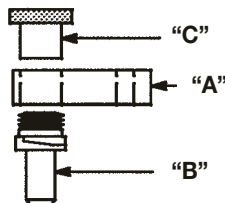

Ref.	Description	Part No.
A	Actuator Arm 21000 Series	58-258
	Actuator Arm 22000 Series	58-430
B	Bushing Tip	—
C	Twistlok Collar 21000 Series	27-116-1
	Twistlok Collar 22000 Series	27-183

## 80-070 Quick Adjustable Yoke Width

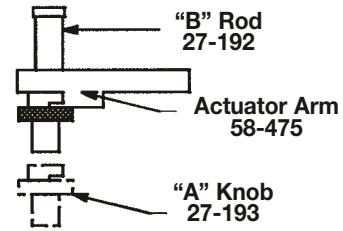

A special Actuator Arm Assembly is available to provide a wide yoke for workpiece access, but then closes and locks for the drilling operation. The Knob ("A") is adjusted and locked onto Rod ("B") to give required yoke width.

## Angle Head Dimensions

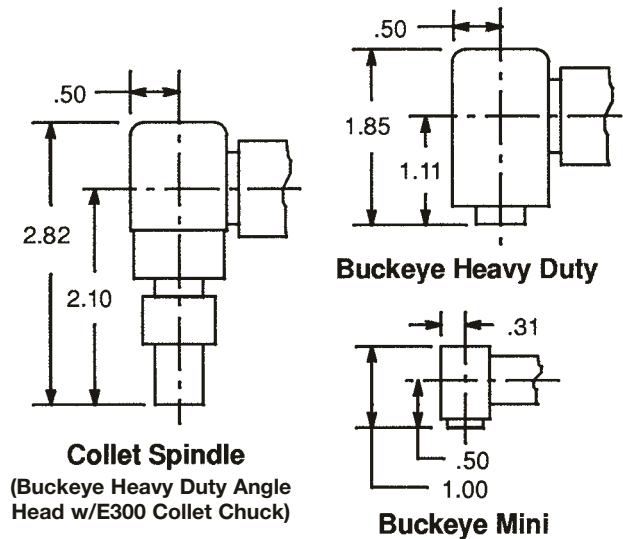

## Collets for Drills - .5625" - 40 Spindles

Number	Drill Size	Number	Drill Size	Number	Drill Size
1005180	.0625	1006049	49	1006199	29
1005181	.0781	1006316	48	1005967	28
1005182	.0938	1006393	47	1005872	27
1005183	.1094	1005875	46	1006373	26
1005184	.125	1006028	45	1006318	25
1005185	.1406	1006297	44	1006372	24
1005186	.1563	1006394	43	1006315	23
1005187	.1719	1006058	42	1005926	22
1005188	.1875	1005928	41	1005682	21
1005994	.60	1005684	40	1005876	20
1006523	.59	1006395	39	1006035	19
1006524	.58	1006396	38	1005964	18
1006525	.57	1006397	37	1005977	17
1006526	.56	1006398	36	1006346	16
1006527	.55	1006027	35	1006399	15
1006528	.54	1005874	34	1006400	14
1006408	.53	1006401	33	1005927	13
1006446	.52	1006050	32	1005871	12
1006412	.51	1005873	31	1006001	11
1005685	.50	1003904	30	1005681	10

## PL-500 Drill Point Lubricator

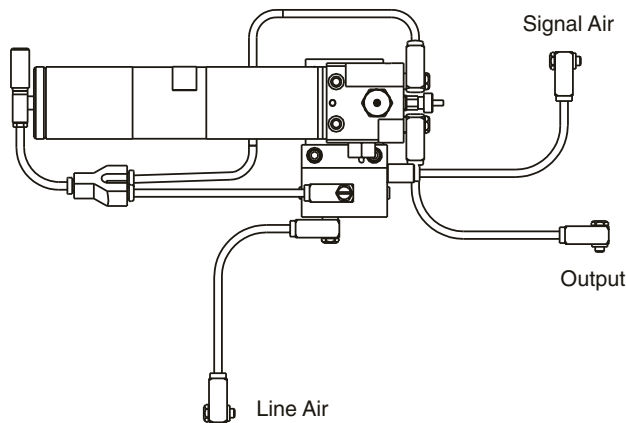

Complete Assembly (including mountig brackets)

85-049 - CD drill  
85-045 - PA/PB2  
85-046 - PA/PB5

Provides lubricated air to the point of the cutter. Mounts on the side of the CD. Has a quick disconnect fitting for rapid no-mess refilling, use 80-503 Wall Tank to refill or, it can be filled manually and requires no additional equipment.

## Dead Handle

Part Number: 80-922

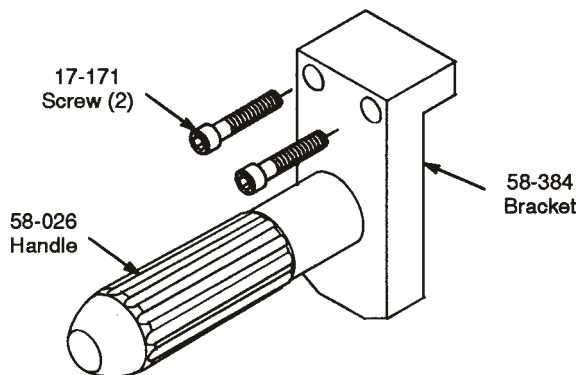

Attach directly to Inner Housing to provide for two-handed operation.

## Mini Twistlok Bushing Tip

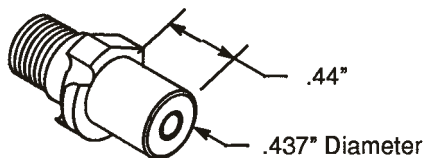

Part Number: 22-700-XXX

Insert the cutter guide diameter for "XXX". For example: 22-700-250 has a .250 guide diameter. Maximum cutter diameter is .313.

Miniature version of Taper-lok Bushing Tips.

## 80-919 Venturi Vacuum System

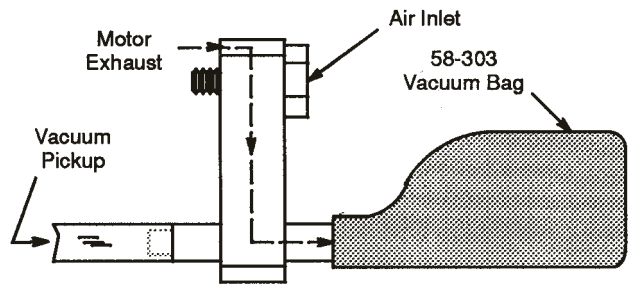

The air motor exhaust is captured and routed thru a venturi port to create a vacuum. This vacuum is then used to pick up dust and small chips that are hazardous to the environment. The dust and chips are collected in a disposable bag.

## Spindle Adapters (use with Jacobs Chuck)

Part Number: 32-074

For .25"-28 x .375 "Spacematic" cutters.

## Special Application Nosepieces

Part No.	Description
27-135	For drilling seat tracks, without countersinks
27-136	For drilling seat tracks, with countersinks

## Fixture Hole Specification for Mini Twistlok

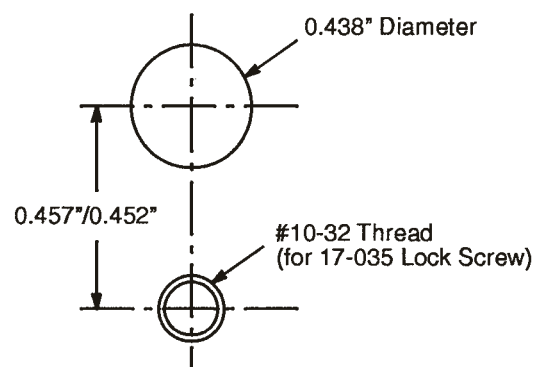



**AIRETOOL®**

**APEX® • BUCKEYE®**

**CAMPBELL® • CLECO®**

**COOPER AUTOMATION™ • CRESCENT®**

**DGD® • DOLER® • DOTCO® • EREM®**

**GARDNER-DENVER® • GARDOTRANS™**

**GETA™ • KAHNETICS® • LUFKIN®**

**MASTER POWER® • METRONIX™**

**NICHOLSON® • PLUMB® • H.K. PORTER®**

**QUACKENBUSH™ • RECOULES™ • ROTOR™**

**UTICA® • WELLER® • WIRE-WRAP®**

**WISS® • XCELITE®**

**CooperTools**

670 Industrial Drive  
Lexington, SC 29072  
Tel: (803) 359-1200  
Fax: (803) 359-0822

**CooperTools**

7007 Pinemont  
Houston, TX 77040  
Tel: (713) 460-7041  
Fax: (713) 462-0482  
[www.dolertools.com](http://www.dolertools.com)  
[www.quackenbushtools.com](http://www.quackenbushtools.com)